

# GRP INSTRUMENT ENCLOSURE AND SUNSHADE



[www.bulksrl.it](http://www.bulksrl.it) | [info@bulksrl.it](mailto:info@bulksrl.it)



## Company Introduction

Pag. 1



## MODEL 115G

Sunshade

External dimension in mm: 180/226 ( width ) x 350 ( depth ) x 130 ( height )

Pag. 4



## MODEL 115N ATEX

Sunshade

External dimension in mm: 180/226 ( width ) x 350 ( depth ) x 130 ( height )

Pag. 5



## MODEL 125G

Sunshade

External dimension in mm: 300/350 ( width ) x 350 ( depth ) x 130 ( height )

Pag. 6



## MODEL 125N ATEX

Sunshade

External dimension in mm: 300/350 ( width ) x 350 ( depth ) x 130 ( height )

Pag. 7



## MODEL 250G

Sunshade

External dimension in mm: 460 ( width ) x 455( depth ) x 350 ( height )

Pag. 8



## MODEL 250N ATEX

Sunshade

External dimension in mm: 460 ( width ) x 455( depth ) x 350 ( height )

Pag. 9



## MODEL 350G

Sunshade

External dimension in mm: 710 ( width ) x 465( depth ) x 340 ( height )

Pag. 10



## MODEL 350N ATEX

Sunshade

External dimension in mm: 710 ( width ) x 465( depth ) x 340 ( height )

Pag. 11



## MODEL 500G1

Enclosure without window

External dimension in mm: 710 ( width ) x 465( depth ) x 340 ( height )

Pag. 12



## MODEL 500G2

Enclosure with window

External dimension in mm: 710 ( width ) x 465( depth ) x 340 ( height )

Pag. 13



## MODEL 500N1 ATEX

Enclosure without window

External dimension in mm: 710 ( width ) x 465( depth ) x 340 ( height )

Pag. 14



## MODEL 500N2 ATEX

Enclosure with window

External dimension in mm: 710 ( width ) x 465( depth ) x 340 ( height )

Pag. 15



## MODEL 700G1

Enclosure without window

External dimension in mm: 710 ( width ) x 395 ( depth ) x 495 ( height )

Pag. 16



## MODEL 700G2

Enclosure with window

External dimension in mm: 710 ( width ) x 395 ( depth ) x 495 ( height )

Pag. 17



## MODEL 700N1 ATEX

Enclosure without window

External dimension in mm: 710 ( width ) x 395 ( depth ) x 495 ( height )

Pag. 18



## MODEL 700N2 ATEX

Enclosure with window

External dimension in mm: 710 ( width ) x 395 ( depth ) x 495 ( height )

Pag. 19



## SOFT ENCLOSURE

Pag. 20



## MOUNTING BRACKET

Pag. 21



## COOLING & HEATING

Pag. 27



## ACCESSORIES

Pag. 28



## CUSTOMIZED PRODUCT

Pag. 31



## CERTIFICATE & TEST

Pag. 33



Catalogue N° 01/16

Dimensions are for reference only, and are subject to change without notice.

All right reserved.

All dimensions are in millimeters.



Office: via Giotto, 7 20032 Cormano (Mi) - Italy  
tel. +39 02 66307514 | +39 02 66307430  
fax +39 02 93664351 | [www.bulksrl.it](http://www.bulksrl.it) | [info@bulksrl.it](mailto:info@bulksrl.it)

Manufacturing unit & Warehouse: via Cimabue, 1/A 20032 Cormano (Mi) - Italy





## The Company

The company, founded in 1999, boasts the experience of being active charter members in the oil & gas market for two decades.

Located on the border of Milan in a modern facility ( owned by the company ), it serves the international market exporting to over 50 countries worldwide through agents or qualified resellers.

BULK srl is certified ISO 9001 and is qualified by major customers in the oil & gas, energy and petrochemical industries for its production of GRP instrument enclosure and sunshade.

Constant investments in research & development and in staff training guarantee our customers reliable products and services over time always updated with the latest regulations.

Products are entirely manufactured in Italy.

## Application

Modern industrial plants guarantee high performances, both in terms of production and safety, through a capillary control of the main operating parameters (flow, pressure, temperature, etc.).

This is possible due to the constant monitoring of the processes through even more sophisticated and reliable measurement instruments.

The malfunction or deterioration of such equipment, however, creates a series of unexpected and costly consequences:

- Replacing installed field instrument
- Slowing or blocking the production due to incorrect alarm signal
- Early additional maintenance not budgeted and scheduled during programmed turn-around.

The causes are multiple and simultaneous:

- Low ambient temperature
- High humidity
- Direct exposure to sunlight
- Particularly aggressive external atmosphere ( installation next to the sea-coast, chemical vapours, fine dust,etc.)
- Sand storms
- Vandalism or accidents because of unprotected or unsupervised installation.

A practical and economical solution is offered by installing the instrumentation within BULK enclosures and/or BULK sunshade made of GRP ( Glassfibre Reinforced Polyester). Such protection ensures the maintenance of the instrument in optimum conditions, preserving performance and measurement repeatability.



## Product Features

Protection enclosures and sunshades are available in various sizes and are hot pressed with a single layer of a reinforced polyester resin reinforced with glass fibre.

The self-extinguishing material is particularly suitable for aggressive and corrosive environments, and is resistant to UV rays.

Light grey colouring is obtained by pigmentation of the polyester resin, and the surfaces are therefore free from paint and/or maintenance operations.

A version made with black anti-static material with low surface resistivity for classified areas is available according to the ATEX standard.

The protective housing is made of equal half-shells which close at 45° line with a double sealing system to ensure a watertight IP 66 protection.

The rotating cover is hinged by means of a removable pin.

The lifting of the lid is accompanied by a locking device which keeps it open.

The closure is secured by two clasps, possibly lockable.

All screws, hinges and clasps are made of stainless steel.

On request, BULK can assemble the instruments and accessories inside the enclosures to provide a product ready for installation.

## Technical notes on the hot pressed GRP ( Glassfibre Reinforced Polyester )

The fibreglass, or GRP ( Glassfibre Reinforced Polyester), is a type of reinforced plastic with glass fibre.

From its first applications in the 50s to today, this particular plastic has been continuously developed and refined both in the composite and in the processing methods.

Today, it operates as a structural element in the aircraft, shipbuilding, petrochemical and automotive industries, to name only the main ones.

Hot pressing method provides the finished product with a number of advantages compared to other types of more economic productions (injection moulding or manual laying): certainly in the repeatability of the thicknesses and geometries, long and continuous glass fibre filaments, greater thicknesses at the most stressed points, and both external and internal excellent surface finish.

In addition to an indisputable superior final appearance, hot pressing guarantees mechanical properties which are unattainable with other production methods.

Thanks to its unique composition and production, hot moulded GRP guarantees:

- High resistance to a wide range of acids, solvents and chlorides
- Excellent heat resistance
- Thermal and electrical insulation
- Excellent weight/mechanical resistance
- No maintenance and absence of oxidation
- Ease of repair

## Applications:

BULK GRP instrument enclosure and sunshades are used in the protection of the following components:

- Field instrument (flow, pressure, temperature, ...)
- Electronic component (actuator, positioner, junction box, ...)
- Sensor (fire, gas, ...)
- Actuator control panel
- Pump





# Instrument Sunshade | Series SS

Instrument protection sunshade  
made in hot pressed GRP  
(Glassfibre Reinforced Polyester)

**Model: 115G**

## Technical Characteristics

- External dimension in mm: 180/226 ( width ) x 350 ( depth ) x 130 ( height )
- Minimum thickness 3 mm
- Weight in kg: 0,6 ( without accessories )
- Light grey color similar to RAL 7032
- Working temperature range: -40°C + 100°C
- Hardly inflammable and self-extinguishing
- Resistant to most corrosive types of industrial environments, acids and alkalis
- Not absorption of hydrocarbons
- High structural strength



Picture shows sunshade fitted with standard mounting bracket.

## Certifications And Approvals

- "V" classification in according to UL 94 June 2009 ( Istituto Giordano test report nr 311399 )
- UV resistant in according to ISO 179-1 ( IMQ test report 43SL00177 )
- EAC CU TR 010/2011 compliance
- Positively tested in wind tunnel up to 160 km/h ( Politecnico di Milano test report nr P48-07 )
- Positively tested Sand and dust Procedure II - Blowing sand in according to MIL-STD-810G METHOD 510.5 ( KIWA test report KIP-089534/01 )
- Positively tested to Salt Mist Corrosion ( KIWA test report KIP-090110/01 )

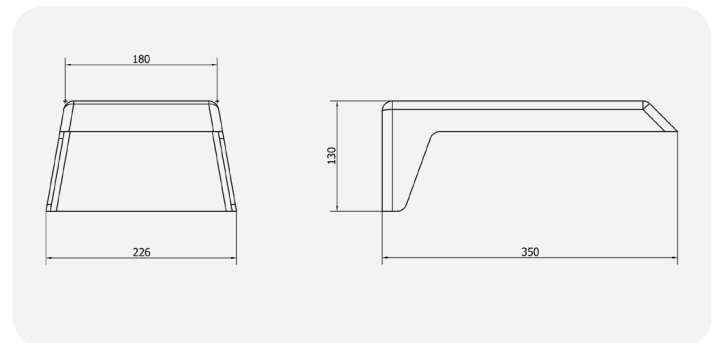

## Options/accessories:

- Antistatic material in according to ATEX: see model 115N
- External mounting bracket suitable for 2" pipe stand: see section MOUNTING BRACKET
- Wall mounting bracket: see section MOUNTING BRACKET
- Self standing mounting bracket: see section MOUNTING BRACKET
- 2" pipe stand: see section MOUNTING BRACKET
- TAG label: see section ACCESSORIES
- Different color: see section CUSTOMIZED PRODUCT
- Custom design: see section CUSTOMIZED PRODUCT

# Instrument Sunshade | Series SS

Instrument protection sunshade  
made in hot pressed GRP  
(Glassfibre Reinforced Polyester)

**Model: 115N**

( ATEX certified – ref. INERIS-EQEN 025354/11 )



## Technical Characteristics

- External dimension in mm: 180/226 ( width ) x 350 ( depth ) x 130 ( height )
- Minimum thickness 3 mm
- Weight in kg: 0,6 ( without accessories )
- Black color
- Working temperature range: -40°C + 100°C
- Hardly inflammable and self-extinguishing
- Resistant to most corrosive types of industrial environments, acids and alkalis
- Not absorption of hydrocarbons
- High structural strength



Picture shows sunshade fitted with standard mounting bracket.

## Certification And Approvals

- ATEX certified ( INERIS certificate EQEN 025354/11 )
- CU TR 012/2011 certified
- "V" classification in according to UL 94 June 2009 ( Istituto Giordano test report nr 311399 )
- UV resistant in according to ISO 179-1 ( IMQ test report 43SL00177 )
- Positively tested in wind tunnel up to 160 km/h ( Politecnico di Milano test report nr P48-07 )
- Positively tested Sand and dust Procedure II - Blowing sand in according to MIL-STD-810G METHOD 510.5 ( KIWA test report KIP-089534/01 )
- Positively tested to Salt Mist Corrosion ( KIWA test report KIP-090110/01 )

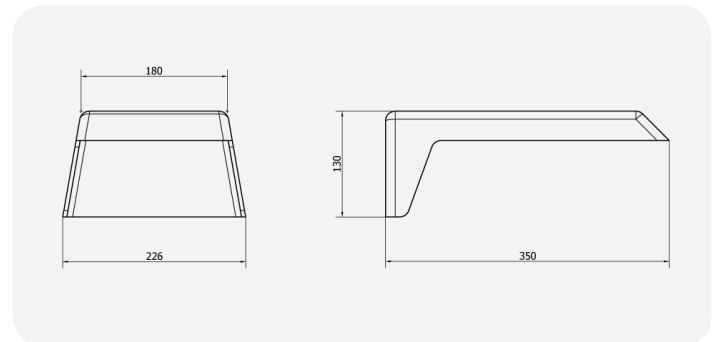

## Options/accessories:

- External mounting bracket suitable for 2" pipe stand: see section MOUNTING BRACKET
- Self standing mounting bracket: see section MOUNTING BRACKET
- Wall mounting bracket: see section MOUNTING BRACKET
- 2" pipe stand: see section MOUNTING BRACKET
- TAG label: see section ACCESSORIES
- Different color: see section CUSTOMIZED PRODUCT
- Custom design: see section CUSTOMIZED PRODUCT

# Instrument Sunshade | Series SS

Instrument protection sunshade  
made in hot pressed GRP  
(Glassfibre Reinforced Polyester)

Model: 125G

## Technical Characteristics

- Instrument protection sunshade made in hot pressed GRP ( Glassfibre Reinforced Polyester )
- External dimension in mm: 300/350 ( width ) x 350 ( depth ) x 130 ( height )
- Minimum thickness 3 mm
- Weight in kg: 1,00 ( without accessories )
- Light grey color similar to RAL 7032
- Working temperature range: -40°C + 100°C
- Hardly inflammable and self-extinguishing
- Resistant to most corrosive types of industrial environments, acids and alkalis
- Not absorption of hydrocarbons
- High structural strength



Picture shows sunshade fitted with standard mounting bracket.

## Certification And Approvals

- "V" classification in according to UL 94 June 2009 ( Istituto Giordano test report nr 311399 )
- UV resistant in according to ISO 179-1 ( IMQ test report 43SL00177 )
- EAC CU TR 010/2011 compliance
- Positively tested in wind tunnel up to 160 km/h ( Politecnico di Milano test report nr P48-07 )
- Positively tested Sand and dust Procedure II - Blowing sand in according to MIL-STD-810G METHOD 510.5 ( KIWA test report KIP-089534/01 )
- Positively tested to Salt Mist Corrosion ( KIWA test report KIP-090110/01 )

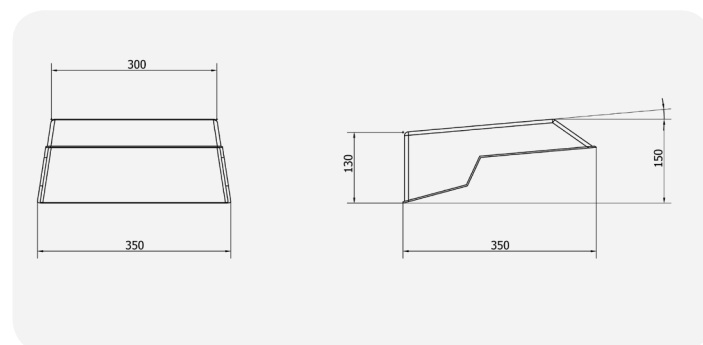

## Options/accessories:

- Antistatic material in according to ATEX: see model 125N
- External mounting bracket suitable for 2" pipe stand: see section MOUNTING BRACKET
- Wall mounting bracket: see section MOUNTING BRACKET
- Self standing mounting bracket: see section MOUNTING BRACKET
- 2" pipe stand: see section MOUNTING BRACKET
- TAG label: see section ACCESSORIES
- Different color: see section CUSTOMIZED PRODUCT
- Custom design: see section CUSTOMIZED PRODUCT

# Instrument Sunshade | Series SS

Instrument protection sunshade  
made in hot pressed GRP  
(Glassfibre Reinforced Polyester)

**Model: 125N**

( ATEX certified – ref. INERIS-EQEN 025354/11 )



## Technical Characteristics

- External dimension in mm: 300/350 ( width ) x 350 ( depth ) x 130 ( height )
- Minimum thickness 3 mm
- Weight in kg: 1,00 ( without accessories )
- Black color
- Working temperature range: -40°C + 100°C
- Hardly inflammable and self-extinguishing
- Resistant to most corrosive types of industrial environments, acids and alkalis
- Not absorption of hydrocarbons
- High structural strength



Picture shows sunshade fitted with standard mounting bracket.

## Certifications And Approval

- ATEX certified ( INERIS certificate EQEN 025354/11 )
- CU TR 012/2011 certified
- "V" classification in according to UL 94 June 2009 ( Istituto Giordano test report nr 311399 )
- UV resistant in according to ISO 179-1 ( IMQ test report 43SL00177 )
- Positively tested in wind tunnel up to 160 km/h ( Politecnico di Milano test report nr P48-07 )
- Positively tested Sand and dust Procedure II - Blowing sand in according to MIL-STD-810G METHOD 510.5 ( KIWA test report KIP-089534/01 )
- Positively tested to Salt Mist Corrosion ( KIWA test report KIP-090110/01 )

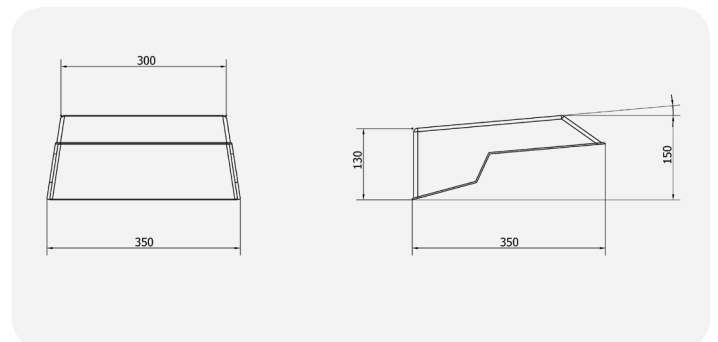

## Options/accessories:

- External mounting bracket suitable for 2" pipe stand: see section MOUNTING BRACKET
- Wall mounting bracket: see section MOUNTING BRACKET
- Self standing mounting bracket: see section MOUNTING BRACKET
- 2" pipe stand: see section MOUNTING BRACKET
- TAG label: see section ACCESSORIES
- Different color: see section CUSTOMIZED PRODUCT
- Custom design: see section CUSTOMIZED PRODUCT

# Instrument Sunshade | Series SS

**Instrument protection sunshade  
made in hot pressed GRP  
(Glassfibre Reinforced Polyester)**

**Model: 250G**

## Technical Characteristics

- External dimension in mm: 460 ( width ) x 455( depth ) x 350 ( height )
- Minimum thickness 5 mm
- Weight in kg: 5,50 ( without accessories )
- Light grey color similar to RAL 7032
- Working temperature range: -40°C + 100°C
- Hardly inflammable and self-extinguishing
- Resistant to most corrosive types of industrial environments, acids and alkalis
- Not absorption of hydrocarbons
- High structural strength



Picture shows sunshade fitted with standard mounting bracket.

## Certification And Approval

- "V" classification in according to UL 94 June 2009 ( Istituto Giordano test report nr 311399 )
- UV resistant in according to ISO 179-1 ( IMQ test report 43SL00177 )
- EAC CU TR 010/2011 compliance
- Positively tested in wind tunnel up to 160 km/h ( Politecnico di Milano test report nr P48-07 )
- Positively tested Sand and dust Procedure II - Blowing sand in according to MIL-STD-810G METHOD 510.5 ( KIWA test report KIP-089534/01 )
- Positively tested to Salt Mist Corrosion ( KIWA test report KIP-090110/01 )

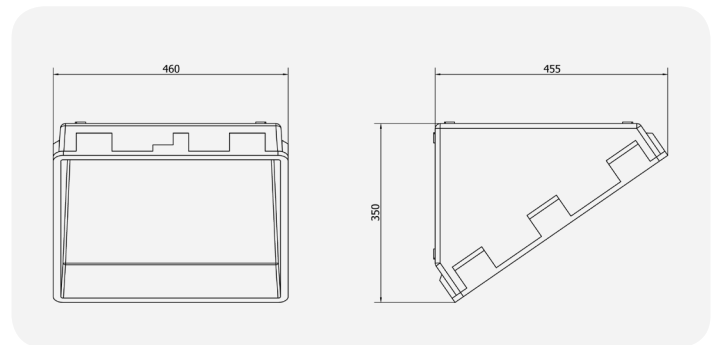

## Options/accessories:

- Antistatic material in according to ATEX: see model 250N
- External mounting bracket suitable for 2" pipe stand: see section MOUNTING BRACKET
- Internal mounting bracket: see section MOUNTING BRACKET
- Wall mounting bracket: see section MOUNTING BRACKET
- 2" pipe stand: see section MOUNTING BRACKET
- TAG label: see section ACCESSORIES
- Different color: see section CUSTOMIZED PRODUCT
- Custom design: see section CUSTOMIZED PRODUCT



# Instrument Sunshade | Series SS

Instrument protection sunshade  
made in hot pressed GRP  
(Glassfibre Reinforced Polyester)

**Model: 250N**

( ATEX certified – ref. INERIS-EQEN 025354/11 )



## Technical Characteristics

- External dimension in mm: 460 ( width ) x 455( depth ) x 350 ( height )
- Minimum thickness 5 mm
- Weight in kg: 5,50 ( without accessories )
- Black color
- Working temperature range: -40°C + 100°C
- Hardly inflammable and self-extinguishing
- Resistant to most corrosive types of industrial environments, acids and alkalis
- Not absorption of hydrocarbons
- High structural strength



Picture shows sunshade fitted with standard mounting bracket.

## Certification And Approval

- ATEX certified ( INERIS certificate EQEN 025354/11 )
- CU TR 012/2011 certified
- "V" classification in according to UL 94 June 2009 ( Istituto Giordano test report nr 311399 )
- UV resistant in according to ISO 179-1 ( IMQ test report 43SL00177 )
- Positively tested in wind tunnel up to 160 km/h ( Politecnico di Milano test report nr P48-07 )
- Positively tested Sand and dust Procedure II - Blowing sand in according to MIL-STD-810G METHOD 510.5 ( KIWA test report KIP-089534/01 )
- Positively tested to Salt Mist Corrosion ( KIWA test report KIP-090110/01 )

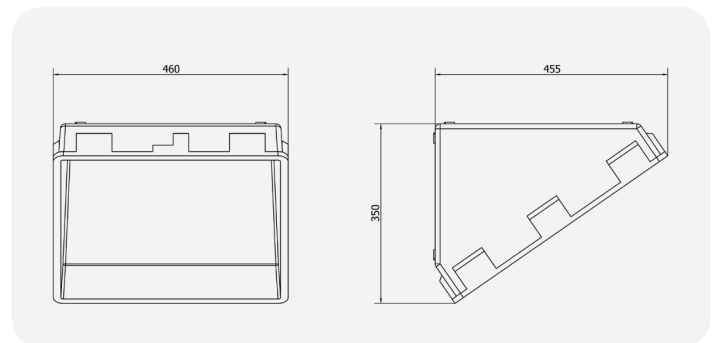

## Options/accessories:

- External mounting bracket suitable for 2" pipe stand: see section MOUNTING BRACKET
- Internal mounting bracket: see section MOUNTING BRACKET
- Wall mounting bracket: see section MOUNTING BRACKET
- 2" pipe stand: see section MOUNTING BRACKET
- TAG label: see section ACCESSORIES
- Different color: see section CUSTOMIZED PRODUCT
- Custom design: see section CUSTOMIZED PRODUCT

# Instrument Sunshade | Series SS

**Instrument protection sunshade  
made in hot pressed GRP  
(Glassfibre Reinforced Polyester)**

**Model: 350G**

## Technical Characteristics

- External dimension in mm: 710 ( width ) x 465( depth ) x 340 ( height )
- Minimum thickness 5 mm
- Weight in kg: 7,50 ( without accessories )
- Light grey color similar to RAL 7032
- Working temperature range: -40°C + 100°C
- Hardly inflammable and self-extinguishing
- Resistant to most corrosive types of industrial environments, acids and alkalis
- Not absorption of hydrocarbons
- High structural strength



Picture shows sunshade fitted with standard mounting bracket.

## Certification And Approval

- "V" classification in according to UL 94 June 2009 ( Istituto Giordano test report nr 311399 )
- UV resistant in according to ISO 179-1 ( IMQ test report 43SL00177 )
- EAC CU TR 010/2011 compliance
- Positively tested in wind tunnel up to 160 km/h ( Politecnico di Milano test report nr P48-07 )
- Positively tested Sand and dust Procedure II - Blowing sand in according to MIL-STD-810G METHOD 510.5 ( KIWA test report KIP-089534/01 )
- Positively tested to Salt Mist Corrosion ( KIWA test report KIP-090110/01 )

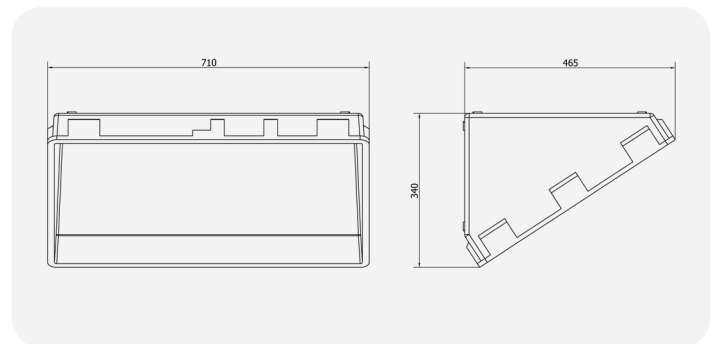

## Options/accessories:

- Antistatic material in according to ATEX: see model 350N
- External mounting bracket suitable for 2" pipe stand: see section MOUNTING BRACKET
- Internal mounting bracket: see section MOUNTING BRACKET
- Wall mounting bracket: see section MOUNTING BRACKET
- 2" pipe stand: see section MOUNTING BRACKET
- TAG label: see section ACCESSORIES
- Different color: see section CUSTOMIZED PRODUCT
- Custom design: see section CUSTOMIZED PRODUCT

# Instrument Sunshade | Series SS

**Instrument protection sunshade  
made in hot pressed GRP  
(Glassfibre Reinforced Polyester)**

**Model: 350N**

( ATEX certified – ref. INERIS-EQEN 025354/11 )



## Technical Characteristics

- External dimension in mm: 710 ( width ) x 465( depth ) x 340 ( height )
- Minimum thickness 5 mm
- Weight in kg: 7,50 ( without accessories )
- Black color
- Working temperature range: -40°C + 100°C
- Hardly inflammable and self-extinguishing
- Resistant to most corrosive types of industrial environments, acids and alkalis
- Not absorption of hydrocarbons
- High structural strength



Picture shows sunshade fitted with standard mounting bracket.

## Certification And Approval

- ATEX certified ( INERIS certificate EQEN 025354/11 )
- CU TR 012/2011 certified
- "V" classification in according to UL 94 June 2009 ( Istituto Giordano test report nr 311399 )
- UV resistant in according to ISO 179-1 ( IMQ test report 43SL00177 )
- Positively tested in wind tunnel up to 160 km/h ( Politecnico di Milano test report nr P48-07 )
- Positively tested Sand and dust Procedure II - Blowing sand in according to MIL-STD-810G METHOD 510.5 ( KIWA test report KIP-089534/01 )
- Positively tested to Salt Mist Corrosion ( KIWA test report KIP-090110/01 )

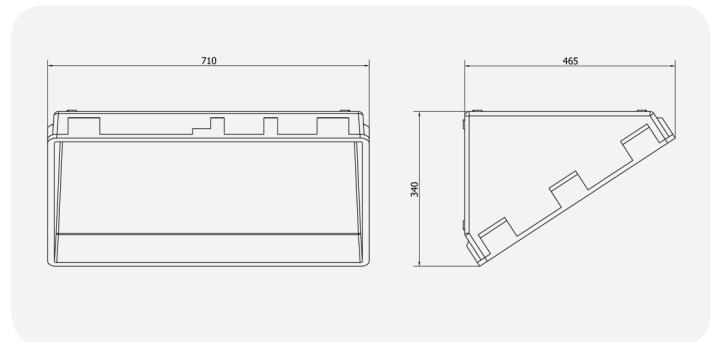

## Options/accessories:

- External mounting bracket suitable for 2" pipe stand: see section MOUNTING BRACKET
- Internal mounting bracket: see section MOUNTING BRACKET
- Wall mounting bracket: see section MOUNTING BRACKET
- 2" pipe stand: see section MOUNTING BRACKET
- TAG label: see section ACCESSORIES
- Different color: see section CUSTOMIZED PRODUCT
- Custom design: see section CUSTOMIZED PRODUCT

# Instrument Enclosure | Series IE

Instrument protection enclosure  
made in hot pressed GRP  
(Glassfibre Reinforced Polyester)

**Model: 500G1**

## Technical Characteristics

- External dimension in mm: 460 ( width ) x 410 ( depth ) x 490 ( height )
- Minimum thickness 5 mm
- Weight in kg: 7,50 ( without accessories )
- Hinges, clasps and lid propstay made in stainless steel
- Gasket made in EPDM
- Light grey color similar to RAL 7032
- Working temperature range: -40°C + 100°C
- Hardly inflammable and self-extinguishing
- Resistant to most corrosive types of industrial environments, acids and alkalis
- Not absorption of hydrocarbons
- High structural strength
- Resilient and mechanical double seal system

## Certification And Approval

- "V" classification in according to UL 94 June 2009 ( Istituto Giordano test report nr 311399 )
- UV resistant in according to ISO 179-1 ( IMQ test report 43SL00177 )
- EAC CU TR 010/2011 compliance
- IP 66 construction ( NEMKO test report nr 189859-1TRFENV )
- Positively tested in wind tunnel up to 160 km/h ( Politecnico di Milano test report nr P48-07 )
- Positively tested Sand and dust Procedure II - Blowing sand in according to MIL-STD-810G METHOD 510.5 ( KIWA test report KIP-089534/01 )
- Positively tested to Salt Mist Corrosion ( KIWA test report KIP-090110/01 )

## Options/accessories:

- Antistatic material in according to ATEX: see model 500N1
- Glass window: see model 500G2
- Gasket in silicone for temperature down to - 60°C: specify model 501G1
- External mounting bracket suitable for 2" pipe stand: see section MOUNTING BRACKET
- Internal mounting bracket for instrument/manifold support: see section MOUNTING BRACKET
- Wall mounting bracket: see section MOUNTING BRACKET



Picture shows enclosure fitted with standard mounting bracket.

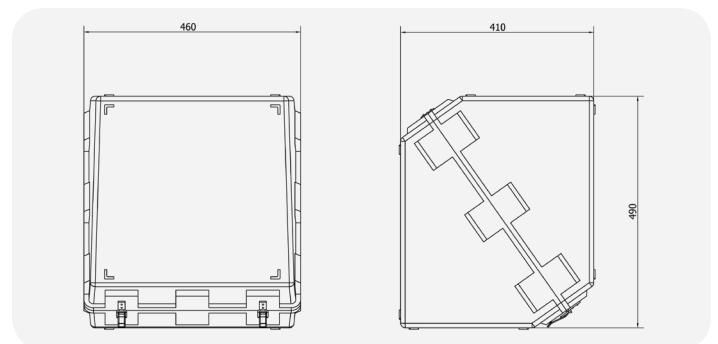

- 2" pipe stand: see section MOUNTING BRACKET
- Different color: see section CUSTOMIZED PRODUCT
- Custom design: see section CUSTOMIZED PRODUCT
- Insulation: see section COOLING & HEATING
- Heating: see section COOLING & HEATING
- Drain / vent valve: see section ACCESSORIES
- Through holes: see section ACCESSORIES
- TAG label: see section ACCESSORIES

# Instrument Enclosure | Series IE

Instrument protection enclosure  
made in hot pressed GRP  
(Glassfibre Reinforced Polyester)

**Model: 500G2**

## Technical Characteristics

- External dimension in mm: 460 ( width ) x 410 ( depth ) x 490 ( height )
- Minimum thickness 5 mm
- Weight in kg: 7,50 ( without accessories )
- Hinges, clasps and lid propstay made in stainless steel
- Gasket made in EPDM
- Window made in safety glass
- Light grey color similar to RAL 7032
- Working temperature range: -40°C + 100°C
- Hardly inflammable and self-extinguishing
- Resistant to most corrosive types of industrial environments, acids and alkalis
- Not absorption of hydrocarbons
- High structural strength
- Resilient and mechanical double seal system

## Certification And Approval

- "V" classification in according to UL 94 June 2009 ( Istituto Giordano test report nr 311399 )
- UV resistant in according to ISO 179-1 ( IMQ test report 43SL00177 )
- EAC CU TR 010/2011 compliance
- IP 66 construction ( NEMKO test report nr 189859-1TRFENV )
- Positively tested in wind tunnel up to 160 km/h ( Politecnico di Milano test report nr P48-07 )
- Positively tested Sand and dust Procedure II - Blowing sand in according to MIL-STD-810G METHOD 510.5 ( KIWA test report KIP-089534/01 )
- Positively tested to Salt Mist Corrosion ( KIWA test report KIP-090110/01 )

## Options/accessories:

- Antistatic material in according to ATEX: see model 500N2
- Without glass window: see model 500G1
- Gasket in silicone for temperature down to - 60°C: specify model 501G2
- External mounting bracket suitable for 2" pipe stand: see section MOUNTING BRACKET
- Internal mounting bracket for instrument/manifold support: see section MOUNTING BRACKET
- Wall mounting bracket: see section MOUNTING BRACKET
- 2" pipe stand: see section MOUNTING BRACKET
- Different color: see section CUSTOMIZED PRODUCT
- Custom design: see section CUSTOMIZED PRODUCT
- Insulation: see section COOLING & HEATING
- Heating: see section COOLING & HEATING
- Drain / vent valve: see section ACCESSORIES
- Through holes: see section ACCESSORIES
- TAG label: see section ACCESSORIES

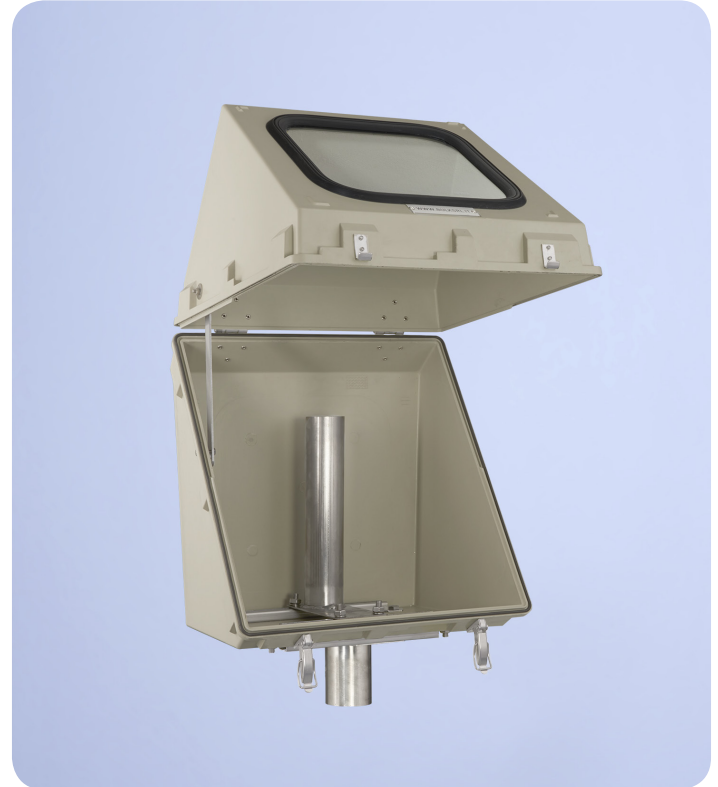

Picture shows enclosure fitted with standard mounting bracket.

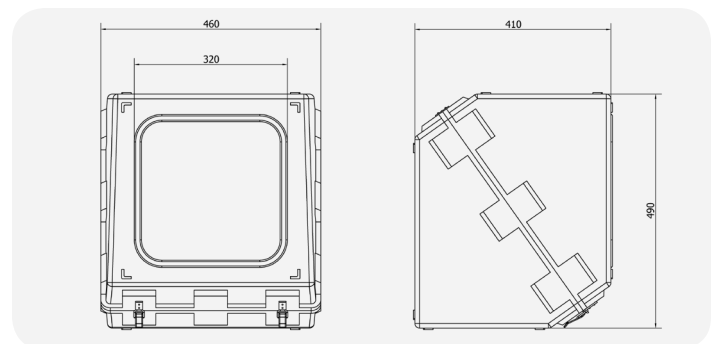



# Instrument Enclosure | Series IE

Instrument protection enclosure  
made in hot pressed GRP  
(Glassfibre Reinforced Polyester)

**Model: 500N1**

( ATEX certified – ref. INERIS-EQEN 025354/11 )



## Technical Characteristics

- External dimension in mm: 460 ( width ) x 410 ( depth ) x 490 ( height )
- Minimum thickness 5 mm
- Weight in kg: 7,50 ( without accessories )
- Hinges, clasps and lid propstay made in stainless steel
- Gasket made in EPDM
- Black color
- Working temperature range: -40°C + 100°C
- Hardly inflammable and self-extinguishing
- Resistant to most corrosive types of industrial environments, acids and alkalis
- Not absorption of hydrocarbons
- High structural strength
- Resilient and mechanical double seal system

## Certification And Approvals

- ATEX certified ( INERIS certificate EQEN 025354/11 )
- CU TR 012/2011 certified
- "V" classification in according to UL 94 June 2009 ( Istituto Giordano test report nr 311399 )
- UV resistant in according to ISO 179-1 ( IMQ test report 43SL00177 )
- IP 66 construction ( NEMKO test report nr 189859-1TRFENV )
- Positively tested in wind tunnel up to 160 km/h ( Politecnico di Milano test report nr P48-07 )
- Positively tested Sand and dust Procedure II - Blowing sand in according to MIL-STD-810G METHOD 510.5 ( KIWA test report KIP-089534/01 )
- Positively tested to Salt Mist Corrosion ( KIWA test report KIP-090110/01 )

## Options/accessories:

- Glass window: see model 500N2
- Gasket in silicone for temperature down to – 60°C: specify model 501N1
- External mounting bracket suitable for 2" pipe stand: see section MOUNTING BRACKET
- Internal mounting bracket for instrument/manifold support: see section MOUNTING BRACKET
- Wall mounting bracket: see section MOUNTING BRACKET
- 2" pipe stand: see section MOUNTING BRACKET
- Different color: see section CUSTOMIZED PRODUCT
- Custom design: see section CUSTOMIZED PRODUCT
- Insulation: see section COOLING & HEATING
- Heating: see section COOLING & HEATING
- Drain / vent valve: see section ACCESSORIES



Picture shows enclosure fitted with standard mounting bracket.

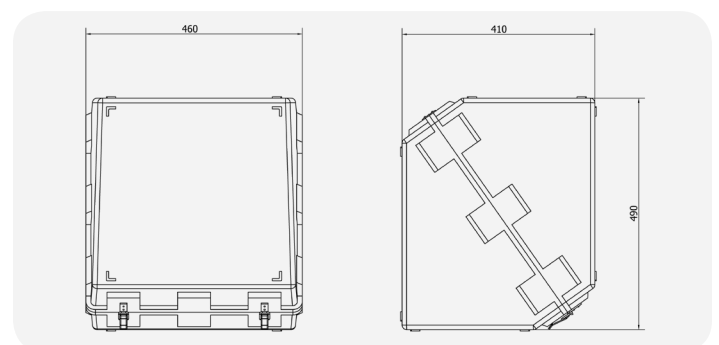

IMPORTANT NOTE: ATEX certification covers only the enclosure, any product installed inside must be certified for hazardous area

- Through holes: see section ACCESSORIES
- TAG label: see section ACCESSORIES

# Instrument Enclosure | Series IE

Instrument protection enclosure  
made in hot pressed GRP  
(Glassfibre Reinforced Polyester)

**Model: 500N2**

( ATEX certified – ref. INERIS-EQEN 025354/11 )



## Technical Characteristics

- External dimension in mm: 460 ( width ) x 410 ( depth ) x 490 ( height )
- Minimum thickness 5 mm
- Weight in kg: 7,50 ( without accessories )
- Hinges, clasps and lid propstay made in stainless steel
- Gasket made in EPDM
- Window made in safety glass
- Black color
- Working temperature range: -40°C + 100°C
- Hardly inflammable and self-extinguishing
- Resistant to most corrosive types of industrial environments, acids and alkalis
- Not absorption of hydrocarbons
- High structural strength
- Resilient and mechanical double seal system

## Certification And Approval

- ATEX certified ( INERIS certificate EQEN 025354/11 )
- CU TR 012/2011 certified
- "V" classification in according to UL 94 June 2009 ( Istituto Giordano test report nr 311399 )
- UV resistant in according to ISO 179-1 ( IMQ test report 43SL00177 )
- IP 66 construction ( NEMKO test report nr 189859-1TRFENV )
- Positively tested in wind tunnel up to 160 km/h ( Politecnico di Milano test report nr P48-07 )
- Positively tested Sand and dust Procedure II - Blowing sand in according to MIL-STD-810G METHOD 510.5 ( KIWA test report KIP-089534/01 )
- Positively tested to Salt Mist Corrosion ( KIWA test report KIP-090110/01 )

## Options/accessories:

- Without glass window: see model 500N1
- Gasket in silicone for temperature down to – 60°C: specify model 501N2
- External mounting bracket suitable for 2" pipe stand: see section MOUNTING BRACKET
- Internal mounting bracket for instrument/manifold support: see section MOUNTING BRACKET
- Wall mounting bracket: see section MOUNTING BRACKET
- 2" pipe stand: see section MOUNTING BRACKET
- Different color: see section CUSTOMIZED PRODUCT
- Custom design: see section CUSTOMIZED PRODUCT
- Insulation: see section COOLING & HEATING
- Heating: see section COOLING & HEATING
- Drain / vent valve: see section ACCESSORIES



Picture shows enclosure fitted with standard mounting bracket.

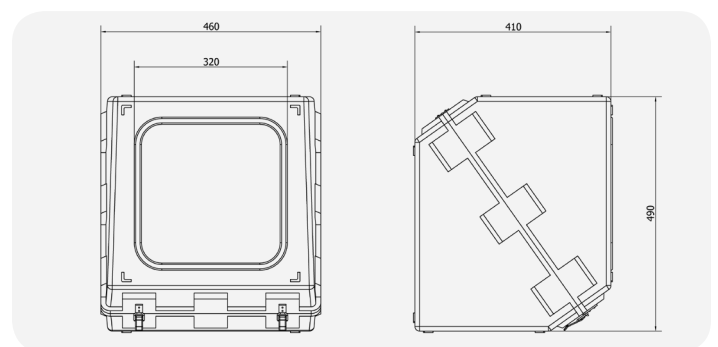

IMPORTANT NOTE: ATEX certification covers only the enclosure, any product installed inside must be certified for hazardous area

- Through holes: see section ACCESSORIES
- TAG label: see section ACCESSORIES
- TAG label: see section ACCESSORIES

# Instrument Enclosure | Series IE

Instrument protection enclosure  
made in hot pressed GRP  
(Glassfibre Reinforced Polyester)

**Model: 700G1**

## Technical Characteristics

- External dimension in mm: 710 ( width ) x 395 ( depth ) x 495 ( height )
- Minimum thickness 5 mm
- Weight in kg: 10,00 ( without accessories )
- Hinges, clasps and lid propstay made in stainless steel
- Gasket made in EPDM
- Light grey color similar to RAL 7032
- Working temperature range: -40°C + 100°C
- Hardly inflammable and self-extinguishing
- Resistant to most corrosive types of industrial environments, acids and alkalis
- Not absorption of hydrocarbons
- High structural strength
- Resilient and mechanical double seal system

## Certification And Approvals

- "V" classification in according to UL 94 June 2009 ( Istituto Giordano test report nr 311399 )
- UV resistant in according to ISO 179-1 ( IMQ test report 43SL00177 )
- EAC CU TR 010/2011 compliance
- IP 66 construction ( NEMKO test report nr 189859-1TRFENV )
- Positively tested in wind tunnel up to 160 km/h ( Politecnico di Milano test report nr P48-07 )
- Positively tested Sand and dust Procedure II - Blowing sand in according to MIL-STD-810G METHOD 510.5 ( KIWA test report KIP-089534/01 )
- Positively tested to Salt Mist Corrosion ( KIWA test report KIP-090110/01 )

## Options/accessories:

- Antistatic material in according to ATEX: see model 700N1
- Glass window: see model 700G2
- Gasket in silicone for temperature down to - 60°C: specify model 701G1
- External mounting bracket suitable for 2" pipe stand: see section MOUNTING BRACKET
- Internal mounting bracket for instrument/manifold support: see section MOUNTING BRACKET
- Wall mounting bracket: see section MOUNTING BRACKET
- 2" pipe stand: see section MOUNTING BRACKET
- Different color: see section CUSTOMIZED PRODUCT
- Custom design: see section CUSTOMIZED PRODUCT
- Insulation: see section COOLING & HEATING
- Heating: see section COOLING & HEATING
- Drain / vent valve: see section ACCESSORIES
- Through holes: see section ACCESSORIES
- TAG label: see section ACCESSORIES



Picture shows enclosure fitted with standard mounting bracket.

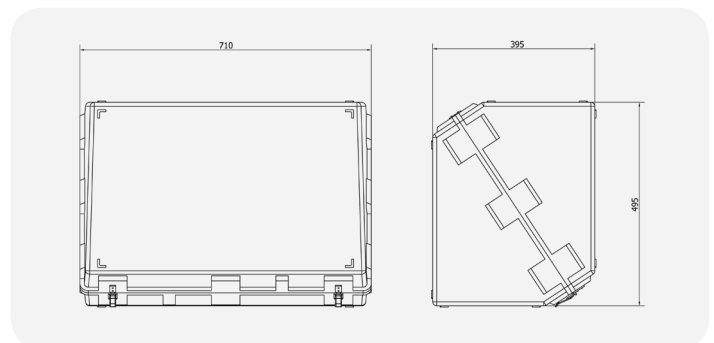



# Instrument Enclosure | Series IE

Instrument protection enclosure  
made in hot pressed GRP  
(Glassfibre Reinforced Polyester)

Model: 700G2

## Technical Characteristics

- External dimension in mm: 710 ( width ) x 395 ( depth ) x 495 ( height )
- Minimum thickness 5 mm
- Weight in kg: 10,00 ( without accessories )
- Hinges, clasps and lid propstay made in stainless steel
- Gasket made in EPDM
- Window made in safety glass
- Light grey color similar to RAL 7032
- Working temperature range: -40°C + 100°C
- Hardly inflammable and self-extinguishing
- Resistant to most corrosive types of industrial environments, acids and alkalis
- Not absorption of hydrocarbons
- High structural strength
- Resilient and mechanical double seal system

## Certification And Approvals

- "V" classification in according to UL 94 June 2009 ( Istituto Giordano test report nr 311399 )
- UV resistant in according to ISO 179-1 ( IMQ test report 43SL00177 )
- EAC CU TR 010/2011 compliance
- IP 66 construction ( NEMKO test report nr 189859-1TRFENV )
- Positively tested in wind tunnel up to 160 km/h ( Politecnico di Milano test report nr P48-07 )
- Positively tested Sand and dust Procedure II - Blowing sand in according to MIL-STD-810G METHOD 510.5 ( KIWA test report KIP-089534/01 )
- Positively tested to Salt Mist Corrosion ( KIWA test report KIP-090110/01 )

## Options/accessories:

- Antistatic material in according to ATEX: see model 700N2
- Without glass window: see model 700G1
- Gasket in silicone for temperature down to - 60°C: specify model 701G2
- External mounting bracket suitable for 2" pipe stand: see section MOUNTING BRACKET
- Internal mounting bracket for instrument/manifold support: see section MOUNTING BRACKET
- Wall mounting bracket: see section MOUNTING BRACKET
- 2" pipe stand: see section MOUNTING BRACKET
- Different color: see section CUSTOMIZED PRODUCT
- Custom design: see section CUSTOMIZED PRODUCT
- Insulation: see section COOLING & HEATING
- Heating: see section COOLING & HEATING
- Drain / vent valve: see section ACCESSORIES
- Through holes: see section ACCESSORIES
- TAG label: see section ACCESSORIES

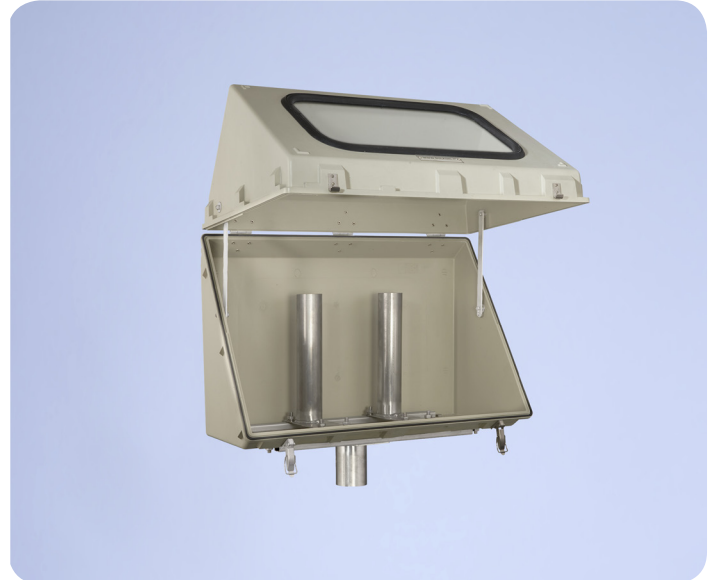

Picture shows enclosure fitted with standard mounting bracket.

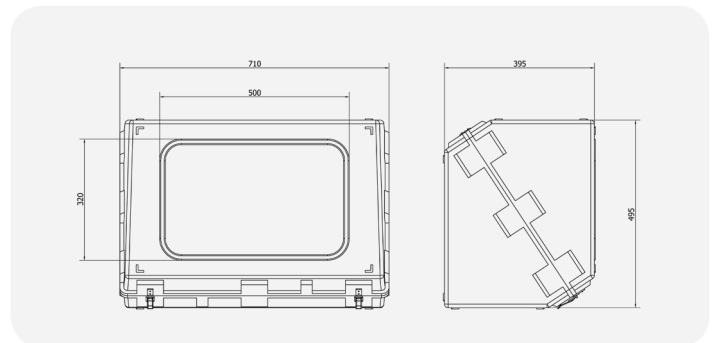

# Instrument Enclosure | Series IE

Instrument protection enclosure  
made in hot pressed GRP  
(Glassfibre Reinforced Polyester)

**Model: 700N1**

( ATEX certified – ref. INERIS-EQEN 025354/11 )



## Technical Characteristics

- External dimension in mm: 710 ( width ) x 395 ( depth ) x 495 ( height )
- Minimum thickness 5 mm
- Weight in kg: 10,00 ( without accessories )
- Hinges, clasps and lid propstay made in stainless steel
- Gasket made in EPDM
- Black color
- Working temperature range: -40°C + 100°C
- Hardly inflammable and self-extinguishing
- Resistant to most corrosive types of industrial environments, acids and alkalis
- Not absorption of hydrocarbons
- High structural strength
- Resilient and mechanical double seal system

## Certification And Approvals

- ATEX certified ( INERIS certificate EQEN 025354/11 )
- CU TR 012/2011 certified
- "V" classification in according to UL 94 June 2009 ( Istituto Giordano test report nr 311399 )
- UV resistant in according to ISO 179-1 ( IMQ test report 43SL00177 )
- IP 66 construction ( NEMKO test report nr 189859-1TRFENV )
- Positively tested in wind tunnel up to 160 km/h ( Politecnico di Milano test report nr P48-07 )
- Positively tested Sand and dust Procedure II - Blowing sand in according to MIL-STD-810G METHOD 510.5 ( KIWA test report KIP-089534/01 )
- Positively tested to Salt Mist Corrosion ( KIWA test report KIP-090110/01 )

## Options/accessories:

- Glass window: see model 700N2
- Gasket in silicone for temperature down to – 60°C: specify model 701N1
- External mounting bracket suitable for 2" pipe stand: see section MOUNTING BRACKET
- Internal mounting bracket for instrument/manifold support: see section MOUNTING BRACKET
- Wall mounting bracket: see section MOUNTING BRACKET
- 2" pipe stand: see section MOUNTING BRACKET
- Different color: see section CUSTOMIZED PRODUCT
- Custom design: see section CUSTOMIZED PRODUCT

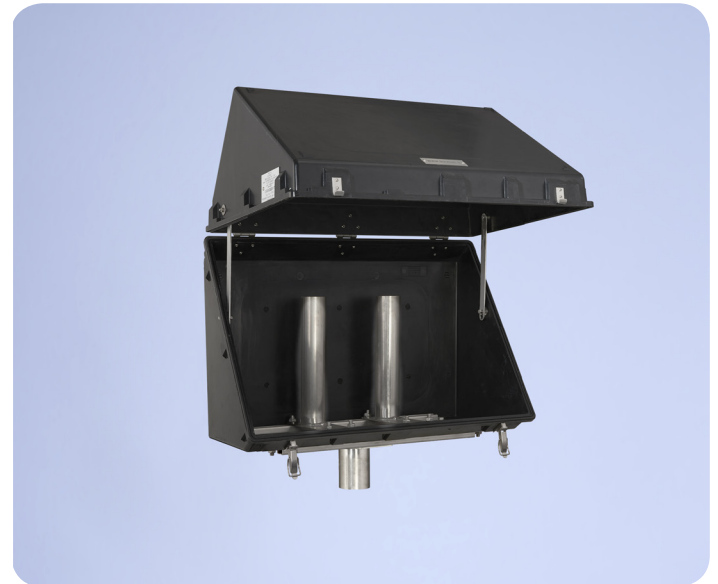

Picture shows enclosure fitted with standard mounting bracket.

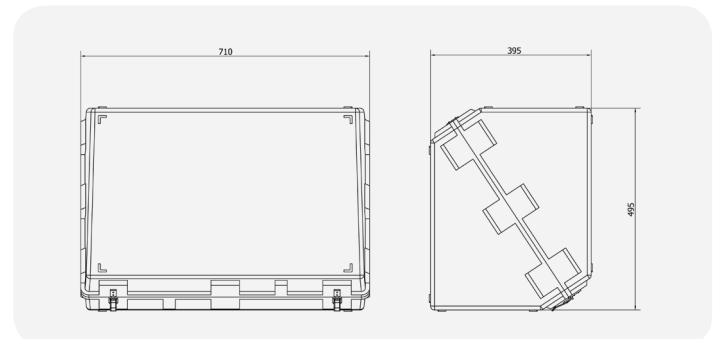

IMPORTANT NOTE: ATEX certification covers only the enclosure, any product installed inside must be certified for hazardous area

- Insulation: see section COOLING & HEATING
- Heating: see section COOLING & HEATING
- Drain / vent valve: see section ACCESSORIES
- Through holes: see section ACCESSORIES
- TAG label: see section ACCESSORIES

# Instrument Enclosure | Series IE

Instrument protection enclosure  
made in hot pressed GRP  
(Glassfibre Reinforced Polyester)

**Model: 700N2**

( ATEX certified – ref. INERIS-EQEN 025354/11 )



## Technical Characteristics

- External dimension in mm: 710 ( width ) x 395 ( depth ) x 495 ( height )
- Minimum thickness 5 mm
- Weight in kg: 10,00 ( without accessories )
- Hinges, clasps and lid propstay made in stainless steel
- Gasket made in EPDM
- Window made in safety glass
- Black color
- Working temperature range: -40°C + 100°C
- Hardly inflammable and self-extinguishing
- Resistant to most corrosive types of industrial environments, acids and alkalis
- Not absorption of hydrocarbons
- High structural strength
- Resilient and mechanical double seal system

## Certification And Approvals

- ATEX certified ( INERIS certificate EQEN 025354/11 )
- CU TR 012/2011 certified
- "V" classification in according to UL 94 June 2009 ( Istituto Giordano test report nr 311399 )
- UV resistant in according to ISO 179-1 ( IMQ test report 43SL00177 )
- IP 66 construction ( NEMKO test report nr 189859-1TRFENV )
- Positively tested in wind tunnel up to 160 km/h ( Politecnico di Milano test report nr P48-07 )
- Positively tested Sand and dust Procedure II - Blowing sand in according to MIL-STD-810G METHOD 510.5 ( KIWA test report KIP-089534/01 )
- Positively tested to Salt Mist Corrosion ( KIWA test report KIP-090110/01 )

## Options/accessories:

- Without glass window: see model 700N1
- Gasket in silicone for temperature down to – 60°C: specify model 701N2
- External mounting bracket suitable for 2" pipe stand: see section MOUNTING BRACKET
- Internal mounting bracket for instrument/manifold support: see section MOUNTING BRACKET
- Wall mounting bracket: see section MOUNTING BRACKET
- 2" pipe stand: see section MOUNTING BRACKET
- Different color: see section CUSTOMIZED PRODUCT
- Custom design: see section CUSTOMIZED PRODUCT



Picture shows enclosure fitted with standard mounting bracket.

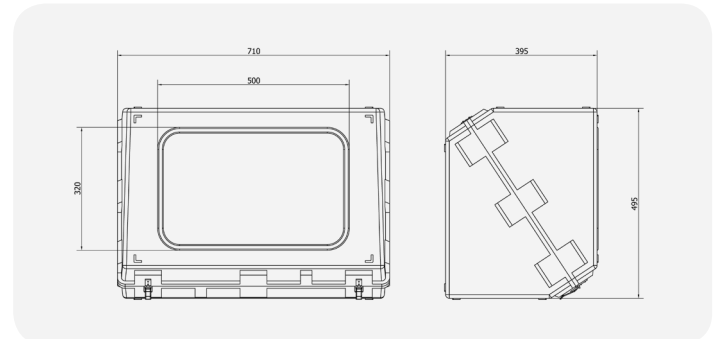

IMPORTANT NOTE: ATEX certification covers only the enclosure, any product installed inside must be certified for hazardous area

- Insulation: see section COOLING & HEATING
- Heating: see section COOLING & HEATING
- Drain / vent valve: see section ACCESSORIES
- Through holes: see section ACCESSORIES
- TAG label: see section ACCESSORIES
- TAG label: see section ACCESSORIES

# Soft Enclosure

## Instrument soft protection enclosure

Bulk Soft Enclosures is a fast and economical alternative to traditional GRP enclosure. Manufactured from Silicone impregnated fiberglass as standard, Soft Enclosures are available in various material thicknesses to suit the particular application conditions. Light weight yet robust construction means that the enclosures are self-supporting, removing the need for costly support frames or brackets. For applications where the internal temperature is to be controlled, electric heaters and associated control equipment can be supplied as an integral part of the enclosure.

## Main Technical Data and Characteristics

- Flame retardant
- Light weight
- Very low installation cost
- Perfect solution for retrofit and for pressure gauge protection
- No support bracket needed
- Plastic socket for TAG label
- Different insulation thickness available
- Suitable for steam or electric heating

Ambient Temperature	From -50 to +150 °C
Cloth Material	Double sided grey silicone impregnated glass cloth
Insulation	from 10 to 20mm thick Mineral Wool Insulation as standard
Fixings & Fastening	Black FR Velcro Hook & Loop Flaps with Draw Cords
Viewing Window	PVC or FEP
Dimension	product are custom made to fit specific device having different size ( instrument, valves, positioner, actuator, ... ).



# External Mounting Bracket

Suitable for mounting enclosure or sunshade on 2" vertical stand pipe  
 Material of construction galvanized carbon steel or AISI 316  
 All nuts and washers are included

## MODEL SP-S1

Suitable for:

- sunshade model 350
  - enclosure model 700 ( rear mounting )
- Model SP-S1-CG made in hot dip galvanized carbon steel  
 Model SP-S1-316 made in AISI 316

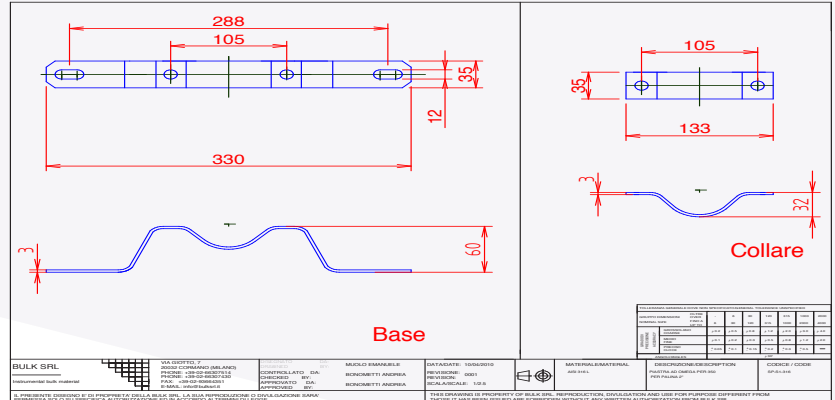

## MODEL SP-S2

Suitable for:

- sunshade model 125
  - sunshade model 250
  - enclosure model 500 ( rear mounting )
- Model SP-S2-CG made in hot dip galvanized carbon steel  
 Model SP-S2-316 made in AISI 316

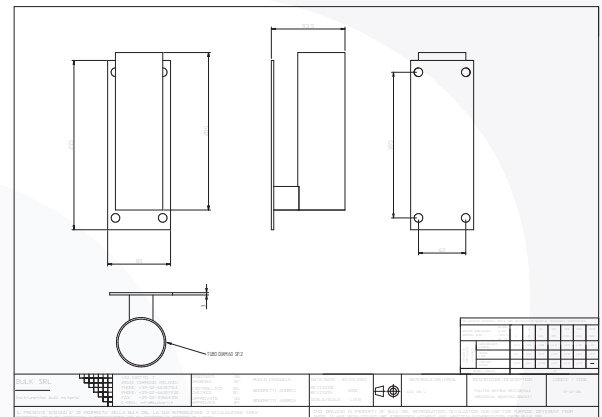

## MODEL SP-S3

Suitable for:

- sunshade model 115
  - sunshade model 125
- Model SP-S3-CG made in galvanized carbon steel  
 Model SP-S3-316 made in AISI 316

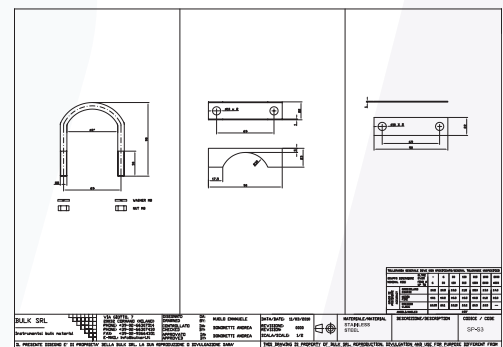

## MODEL SP-E1

Suitable for:

- enclosure 500 ( bottom mounting )
  - enclosure 700 ( bottom mounting )
- Model SP-E1-CG made in hot dip galvanized carbon steel  
 Model SP-E1-316 made in AISI 316

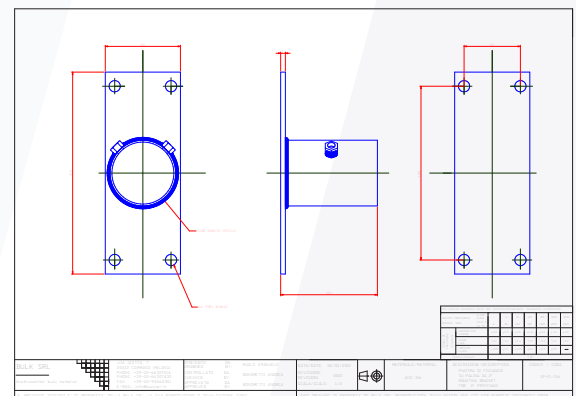



Model SP-E1 is supplied complete with q.ty 2 C rails to allow versatility during installation:

Model PR-500-CG made in hot dip galvanized carbon steel, suitable for model 500  
 Model PR-500-316 made in AISI 316, suitable for model 500

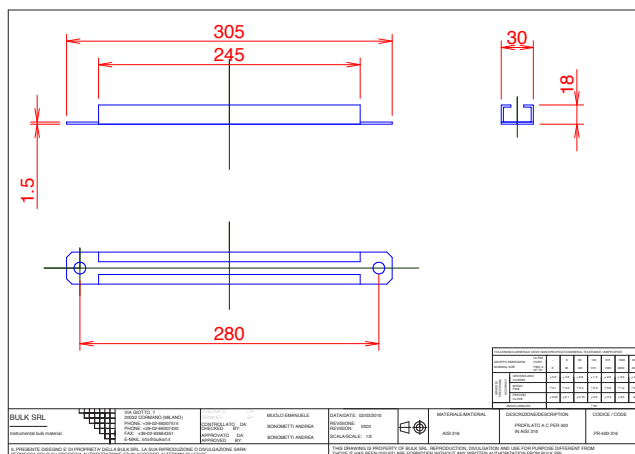

Model PR-700-CG made in hot dip galvanized carbon steel, suitable for model 700  
 Model PR-700-316 made in AISI 316, suitable for model 700

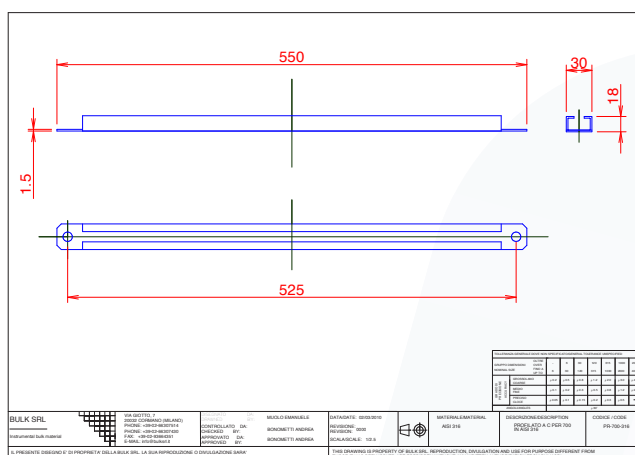

sunshade model 125 fitted with bracket model SP-S2

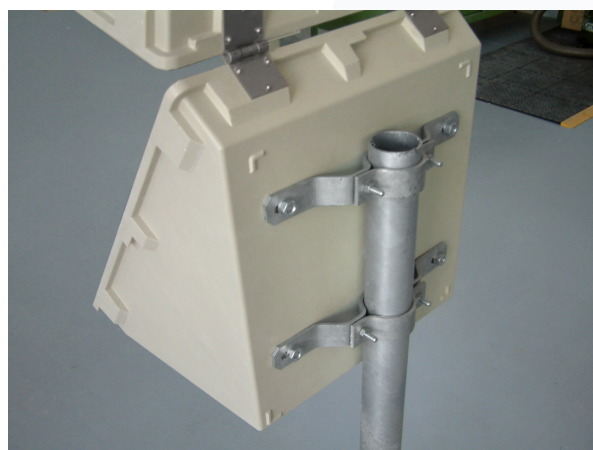

enclosure model 500 fitted with bracket model SP-S2

**OTHER BRACKETS ARE AVAILABLE FOR SPECIAL OR CUSTOM EXECUTION**

Suitable for mounting enclosure or sunshade to wall

Material of construction galvanized carbon steel or AISI 316

All nuts and washers are included ( not for wall side )

Different solution are available, please consult our technical office

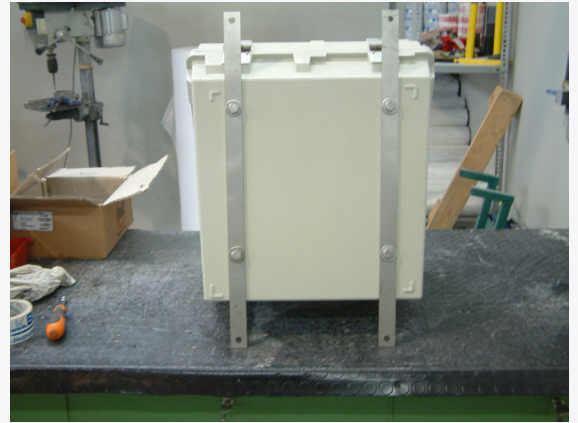

enclosure model 500 fitted with wall mounting bracket

Suitable for mounting sunshade directly on instrument

Material of construction galvanized carbon steel or AISI 316

All nuts and washers are included

Different solution are available, please consult our technical office



# Internal Mounting Bracket

Suitable to support instrument / manifold  
 Material of construction galvanized carbon steel or AISI 316  
 All nuts and washers are included

## MODEL SP-11

Suitable for:

- enclosure 500 ( bottom mounting )
- enclosure 700 ( bottom mounting )

Model SP-11-CG made in hot dip galvanized carbon steel

Model SP-11-316 made in AISI 316

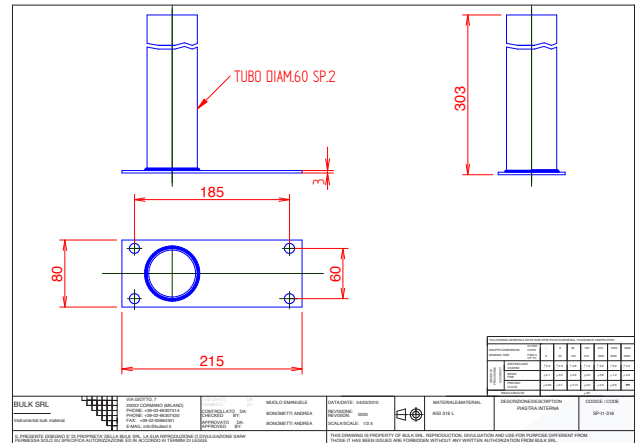

Model SP-11 is supplied complete with q.ty 2 C rails to allow versatility during installation:

Model PR-500-CG made in hot dip galvanized carbon steel, suitable for model 500  
 Model PR-500-316 made in AISI 316, suitable for model 500

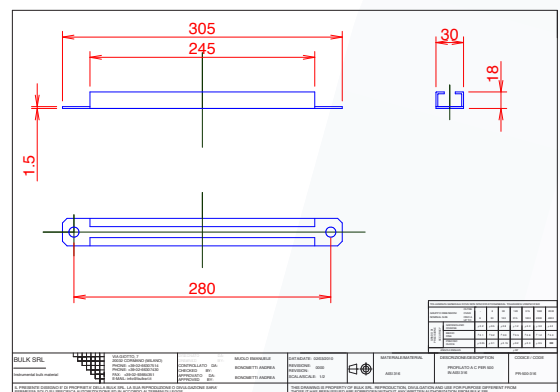

Model PR-700-CG made in hot dip galvanized carbon steel, suitable for model 700  
 Model PR-700-316 made in AISI 316, suitable for model 700

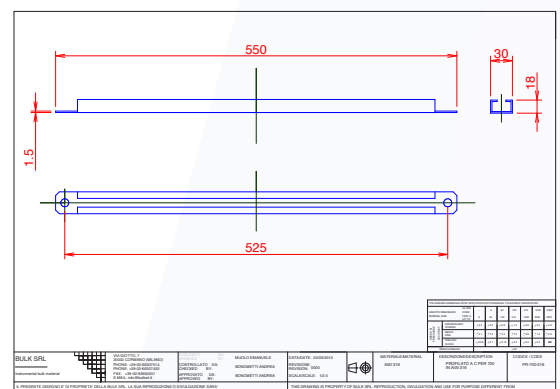

## MODEL SP-12

Suitable for:

- enclosure 500 ( bottom or rear mounting )
- enclosure 700 ( bottom or rear mounting )

Model SP-12-CG made in hot dip galvanized carbon steel

Model SP-12-316 made in AISI 316

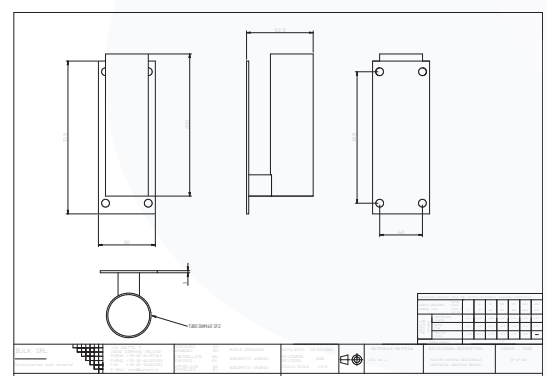



Model SP-I2 is supplied complete with q.ty 2 C rails to allow versatility during installation:

Model SP-I2 is supplied complete with q.ty 2 C rails to allow versatility during installation:

Model PR-500-CG made in hot dip galvanized carbon steel, suitable for model 500  
 Model PR-500-316 made in AISI 316, suitable for model 500

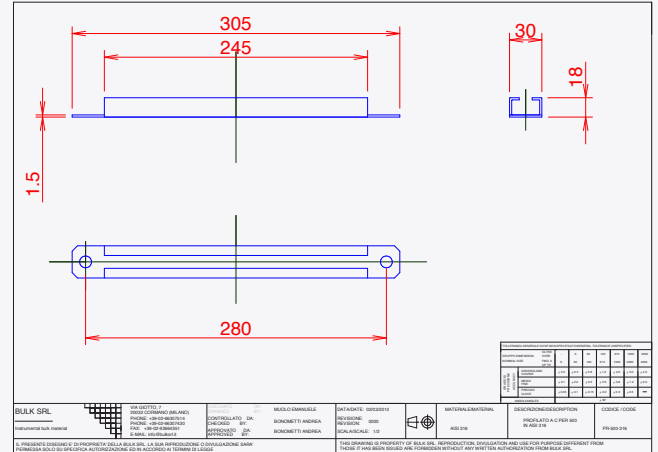

Model PR-700-CG made in hot dip galvanized carbon steel, suitable for model 700  
 Model PR-700-316 made in AISI 316, suitable for model 700

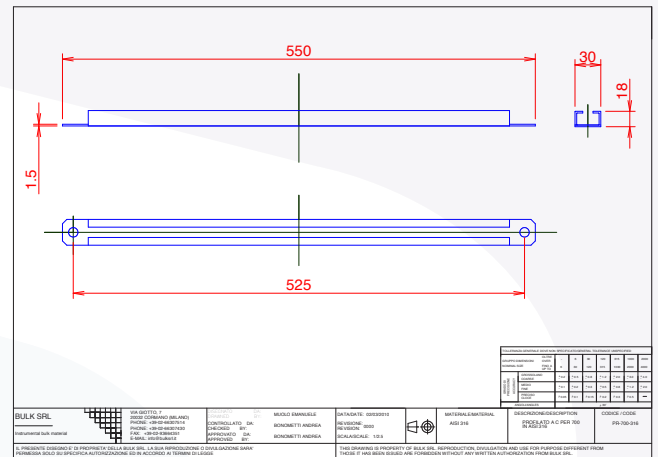

**MODEL AP-1**

Suitable for:  
 - enclosure 500 ( rear mounting )  
 Model AP-1-CG made in galvanized carbon steel  
 Model AP-1-316 made in AISI 316

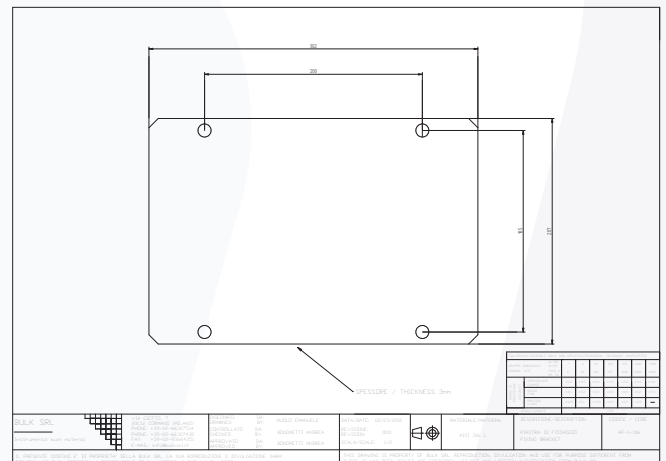

**MODEL AP-2**

Suitable for:  
 - enclosure 700 ( rear mounting )  
 Model AP-2-CG made in galvanized carbon steel  
 Model AP-2-316 made in AISI 316

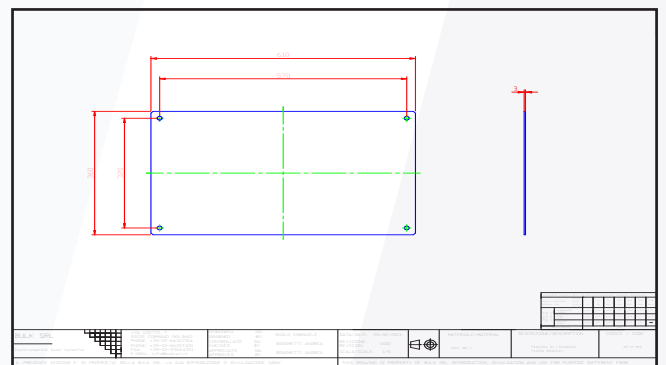

# Examples

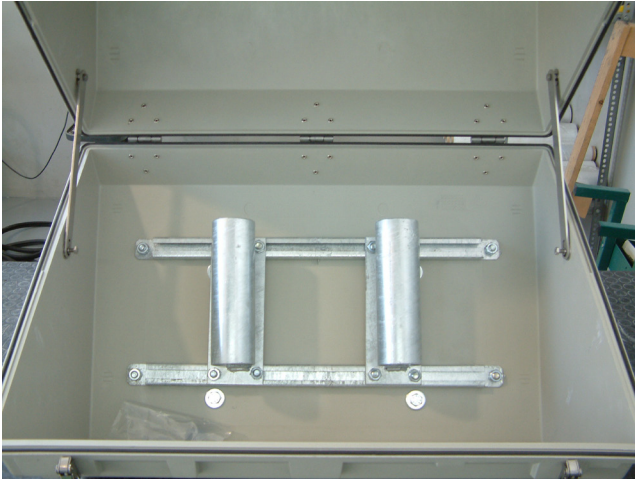

enclosure model 700 fitted with bracket model SP-I2

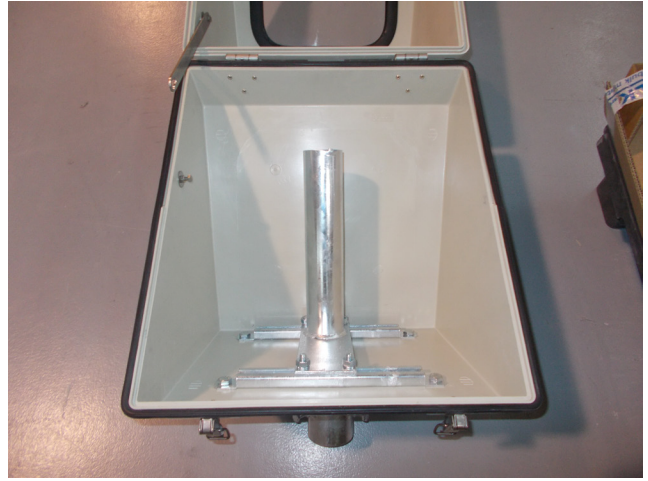

enclosure model 500 fitted with bracket model SP-I1



enclosure model 500 fitted with bracket model AP-1

## OTHER BRACKETS ARE AVAILABLE FOR SPECIAL OR CUSTOM EXECUTION

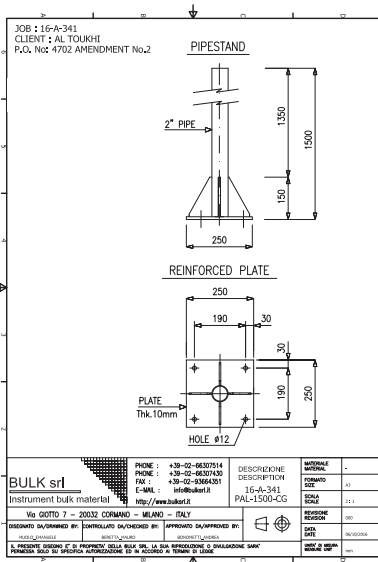

### 2" PIPE STAND

Suitable to support sunshade or enclosure  
 Material of construction hot dip galvanized carbon steel or AISI 316  
 Complete with square base provided with q.ty 4 holes 12 mm diameter  
 Different height, shape and painting available on request.



Model PAL-X-CG made in hot dip galvanized carbon steel ( replace X with required height dimension in mm )  
 Model PAL-X-316 made in AISI 316 ( replace X with required height dimension in mm )

# Cooling and Heating

Instrument enclosures are commonly used to protect instrumentation against adverse weather conditions and to ensure that the instrument operates at the proper temperature range. However, enclosures may not always provide sufficient protection against the temperature extremes that can affect instrument performance. High temperature can cause fluids to vaporize, while low temperature can freeze process lines, resulting in damages to sensitive equipment. The best way to solve this problem is to equip BULK GRP enclosures with accessories designed to maintain interior temperature within the range specified for optimal performance.

Heat could be generate by electrical heater or by steam heating coil.

Electrical heater has self regulating construction but it can be also supplied complete with thermostat ( in line or separate ).

Different version are available for safe or hazardous area, even certified EAC CU TR. Other accessories are available to configure an ideal solution including junction boxes, temperature switch, heat tracing.

Steam heating coil could be made in carbon steel or in AISI 316 in different size and length.

It is possible to control the heating by using a thermostatic valve.

If heat dispersion is needed, enclosure can be supplied complete of metallic louvre grilles.

Louvres allows ventilation, preventing excessive heat or gas/vapour presence inside of enclosure.

It should be used in couple to generate a continues flow.



# Accessories

## PROCESS AND DRAIN TUBING

Process and drain tubing should go through enclosure wall by using one of the following option:

### *Bulkhead twin ferrule compression fittings*

Material of construction AISI 316  
( other material available on request )  
Size from 1/16" o.d. to 1" o.d.,  
from 3 mm o.d. to 25 mm o.d.

Bulkhead union model UP

---



Bulkhead male connector model DMP

---



Bulkhead female connector model DFP

---



### *Rubber grommets*

---

Standard material of construction EPDM  
Temperature range -35°C + 110°C  
( available also in other material for temperature down to - 55°C )

Size suitable to fit:

- 6 mm or 1/4" o.d. tubing
- 10 mm or 3/8" o.d. tubing
- 12 mm or 1/2" o.d. tubing
- other dimension available on request ( 14 mm, 22 mm, .... )





## Special plate

In case of application with capillary impulse line, a special plate should be use.  
Size and dimension are made to fit custom requirement



## POWER SUPPLY AND SIGNAL CABLES

Power supply and signal cables must go through enclosure wall by using of cable glands.

Choice depends from different factor: area classification, external temperature, cable type and size, ...

Material of construction for cable gland: polyamide, brass, nickel plated brass, AISI 304/316/316L.

Available for armoured ( double seal ) or not armoured cable ( single seal ).

Standard thread M20, other size available on request.

Explosion proof or standard execution for safe area available.

Grommets could be also use for this purpose.

## PREINSULATED AND PRETRACED TUBING

Preinsulated and pretraced tubing should go through enclosure wall by using of heat-shrinkable.

Material and dimensions are defined in according to the application.



## INSTRUMENT MANIFOLD

It is available a wide range of instrument manifold especially designed for application inside of the enclosure.



## INFORMATION LABEL

Information label could be useful to identify instrument TAG number placed inside of enclosure or/and to clearly define installing area.

All information, including possible references / instruction / warnings, are permanently engraved on the label.

Different color and size available.

Model TAG-ITEM: made in AISI 316

Model TAG-ITEM-T: made in traffolyte



## VENT AND DRAIN DEVICE

Breather drain allows condensation to drain out from enclosure.

Material of construction is polyamide or AISI 316

Explosion proof or standard execution for safe area.

Valve is located on lower point of the enclosure.

Model D-1 is made in polyamide

Model D-2 is made in AISI 316

# Customized Product

Many customers require special executions to fit their application. The following are some examples of custom product made in the past years:

## Painted sunshade and enclosure

---

It is possible to supply our sunshade and enclosure painted in any industrial color, in according to international standard as RAL or Munsell and to specific customer requirement.



"sunshade serie 125 painted RAL 9010 for KNPC"

## Colored sunshade and enclosure

---

It is possible to supply our sunshade and enclosure indifferent color by adding pigment during production. Availability and cost impact depends from quantity.

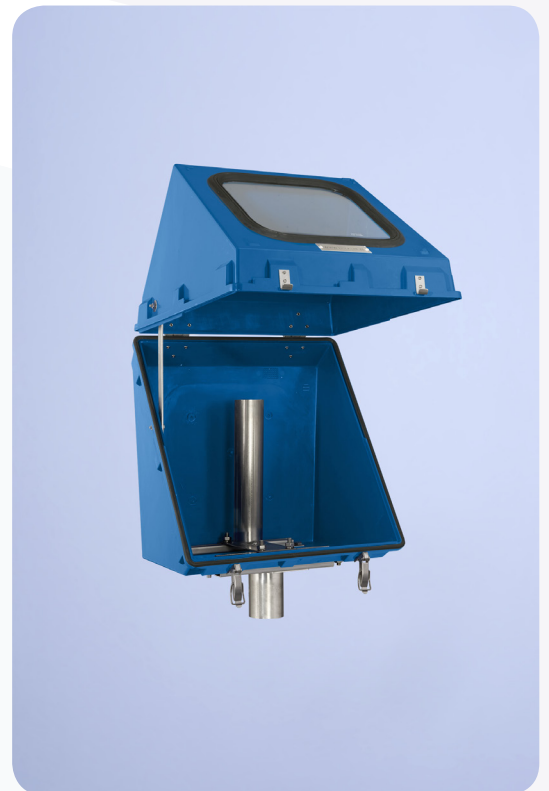

"enclosure serie 500 pigmented RAL 5017 for Gazprom"

## Self-supporting sunshade

---

If 2" stand pipe is not available on field ( i.e. radar instrument installed on top of boiler, magnetic flow meter, temperature transmitter, electrical actuator, ... ), it is possible to use our self-supporting sunshade.

Mounting bracket material is made in galvanized carbon steel or AISI 316

All nuts and washers are included

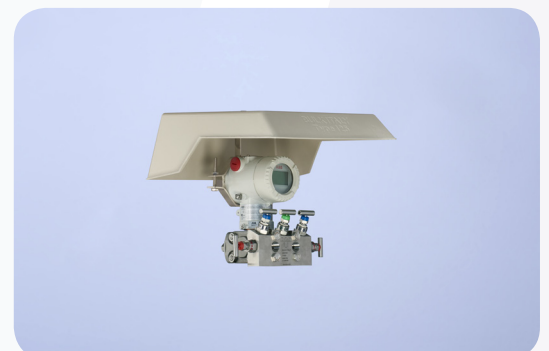

"self standing sunshade for ABB"

## Shaped sunshade

---

We cut our standard sunshade to obtain different shape to protect other devices than field instrument ( i.e. alarm lamps, sirens, ... )



"sunshade serie 350 shaped for sirens for Takreer"

## Stainless and carbon steel sunshade

---

We can supplied sunshade made in different material than GRP ( i.e. AISI 304, AISI 316, galvanized carbon steel, ... ).

Dimension and shape are made as per customer's requirement.



## Valve actuator and positioner protection

---

If upper part of control valve needs protection from external environment, we can insert it into our enclosure duly modified.



## Partial enclosure

---

Our partial enclosure model 300 is available when instrument body is heated with high temperature steam tracing.

This enclosure protect only the instrument body, while electronic housing and display are outside to avoid a possible overheating.



## 0° - 90° Sunshade

If the instrument indicator is located on the top, a 0°-90° sunshade hinge allows operator to lift the canopy and read on field the display. Sunshade is kept on 0° position by a manual lock.

Mounting bracket material is made in galvanized carbon steel or AISI 316  
All nuts and washers are included.



# Certificate and Test

The ability to verify the real performance of our products in the field is reflected in the different tests performed by independent laboratories.

The repeatability of the production systems, the materials used and the intermediate and final tests conducted are guaranteed by ISO 9001 certified procedure. (DNV certificate 90894-2010-AQ-ITA-ACCREDIA)

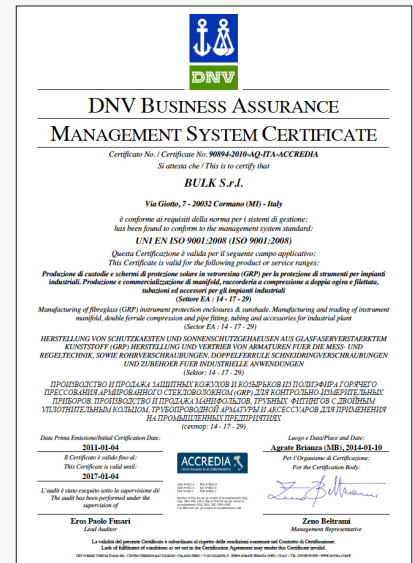

## UV ray

Direct exposure to sunlight is a deteriorating factor in the industrial life of the equipment and the enclosures or sunshade which protects it.

The factors that affect durability and resistance to UV rays are both the thermosetting composition as well as the surface finish.

To prove the effects of sunlight on the installation over time, accelerated ageing tests to reproduce the effect of the attack of UV rays were performed in a laboratory with fiberglass specimens exposed for 1000 hours in order to simulate the aging process and assess its degree of degradation, durability and strength.

The mechanical resilience tests before and after the irradiation treatment confirms that the product falls well within the acceptability criteria of the standard.

(IMQ 43SL00177 Test Report)



## VO Classification

In the unfortunate event of a fire within a production site, the plastic elements must guarantee self-extinguishing characteristics in order to prevent the spread of flames. Tests conducted on the composite according to UL 94 procedures showed a full compliance to the standard V0. (Istituto Giordano test report 311399)

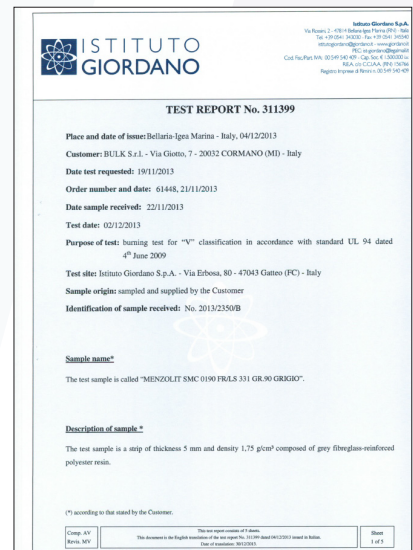

# Watertight integrity

The watertight integrity of an enclosure is essential to preserve the instruments from water, humidity, dust and sand.

To ensure complete waterproofing to external agents, the housings are fitted either with a mechanical labyrinth and a seal placed inside the proper perimeter grooves.

To verify the watertight structure according to Class IP66, different models were tested at independent laboratory. The tests conducted for the resistance to the penetration of dust and water provided full compliance to IP66 requirement

(Test report NEMKO 189859-1 TRFENV and 189859-2 TRFENV)

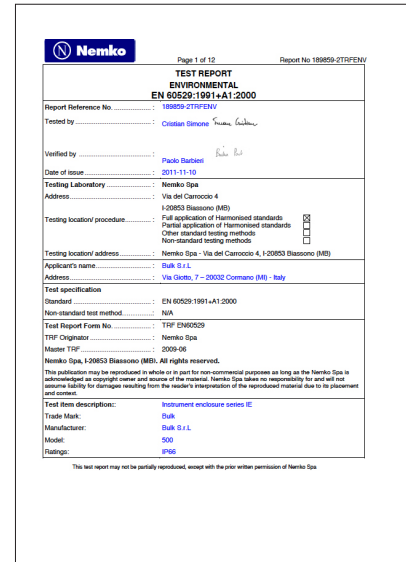

# Wind resistance

Often enclosures and sunshades are installed in areas with the presence of high speed wind.

Resistance to such a solicitation of the structure and the related mounting bracket was evaluated during two days of testing in the wind tunnel at the Milan Polytechnic University.

Different models, alternate locations on a rotary table to simulate the most different wind roses, have positively resisted gusts of 160 km/h.

(Report P 48-07 at the Milan Polytechnic Institute Mechanical Department)

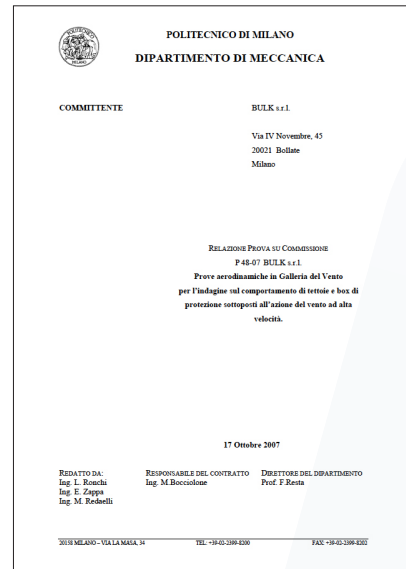

# ATEX

The use of equipment in areas classified as hazardous requires an Analysis of Risks such as with ignition sources. The main danger for enclosures and sunshades is the insulating properties of GRP which can generate superficial eddy currents caused by rubbing or presence of sustained wind speeds.

To ensure a safe installation, BULK has developed a line of products made with a graphite charge having a surface resistivity lower than required by the standard.

Tests conducted on the finished product with an accredited laboratory have yielded positive results, even to the most stringent requirements.

Relative documents submitted by the certifying body allowed obtaining the relevant ATEX certificate (Certificate applicable to "Non-electrical equipment intended for use in potentially explosive atmosphere as per Directive 94/9/IEC").

(ATEX certificate INERIS 025354/11)



## EAC CU TR

EAC certification guarantees the free export of BULK GRP instrument enclosure and sunshade in the following countries: Russia, Belarus and Kazakhstan

One of the developments of the Customs Union (ratified in 2010 among Russia, Belarus and Kazakhstan) is the establishment of a single brand of certification (EAC EurAsian Certification) replacing previous domestic brands GOST.

The recognition of certification EAC certifies compliance of our entire range of products to the stringent legal requirements and Technical Regulations (TR CU).

For standard sunshades & enclosures are available **CERTIFICATE OF COMPLIANCE TO EAC TR CU 010/2011 ON SAFETY OF MACHINERY AND EQUIPMENT**. While for sunshades & enclosures suitable for hazardous area installation **CERTIFICATE EAC TR CU 012/2011 ON SAFETY OF EQUIPMENT FOR USE IN POTENTIAL EXPLOSIVE ATMOSPHERE** is available.

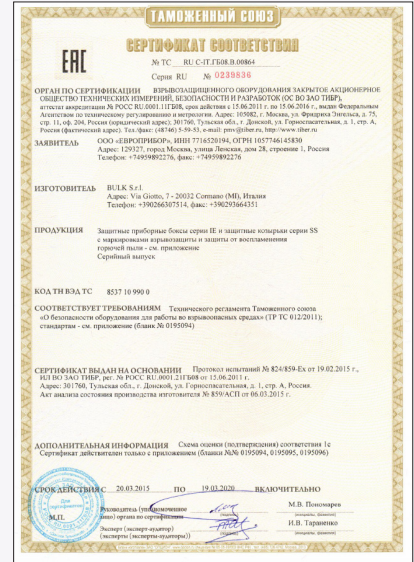

## SAND & SALT MIST

Refineries and water treatment plants are often installed closed to sea and to desert areas.

The combination of salt mist and sand could quickly deteriorate components made in steel even if protected by superficial treatment as galvanizing.

Test made in saline and salt chamber in according to MIL-STD-810G METHOD 510.5 standard, gave a 100% positive result: GRP component resist without any deterioration to sand and salt corrosion.

(KIWA test Report 150700274)



## Power heating sizing

The selection of the correct power in an electrical heater is usually based on generic calculations provided by heater manufactures.

To ensure the correct dimensions of heating elements, heat dispersion tests were conducted in a climate chamber using different power values at different external temperatures.

(NEMKO PT0092/04 Test Report)

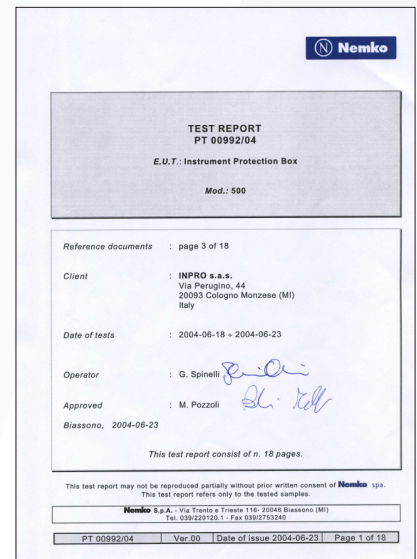



Dimensions are for reference only, and are subject to change without notice.  
All right reserved.  
All dimensions are in millimeters.

