

Przyłączka prosta do spawania  
DIN 3909  
DIN 2353 Form X

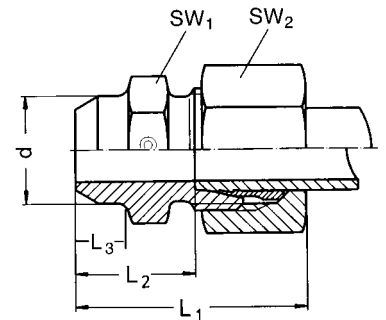

Seria DIN 2353	PN bar	Rura śr. zewn	SW <sub>2</sub>	SW <sub>1</sub>	L <sub>1</sub>	L <sub>2</sub>	L <sub>3</sub>	d	Kod	kg/100szt
XL	315	6	14	12	29	14,0	7	10	AS 6-L	2,5
		8	17	14	31	16,0	8	12	AS 8-L	3,6
		10	19	17	33	18,0	8	14	AS 10-L	4,7
		12	22	19	33	18,0	8	16	AS 12-L	5,5
		15	27	22	37	22,0	10	19	AS 15-L	9,0
		18	32	27	40	23,5	10	22	AS 18-L	13,0
	160	22	36	32	45	28,5	12	27	AS 22-L	19,0
		28	41	41	47	30,5	12	32	AS 28-L	27,0
		35	50	46	54	32,5	14	40	AS 35-L	39,5
		42	60	55	58	35,0	16	46	AS 42-L	58,5
XS	630	6	17	14	34	19,0	7	11	AS 6-S	3,8
		8	19	17	36	21,0	8	13	AS 8-S	5,4
		10	22	19	39	22,5	8	15	AS 10-S	7,0
		12	24	22	41	24,5	10	17	AS 12-S	12,5
		14	27	24	45	27,0	10	19	AS 14-S	14,0
	400	16	30	27	45	26,5	10	21	AS 16-S	15,6
		20	36	32	51	29,5	12	26	AS 20-S	24,0
		25	46	41	56	32,0	12	31	AS 25-S	46,0
		30	50	46	62	35,5	14	36	AS 30-S	55,5
	315	38	60	55	69	38,0	16	44	AS 38-S	78,6

Wymiary są podane w przybliżeniu w zależności od stopnia dokręcenia nakrętek