

Przyłączka prosta gwintowana

gwint stożkowy

DIN 3900

gwint:

BSPT stożkowy - DIN 2353 Form B

metryczny stożkowy - DIN 2353 Form A

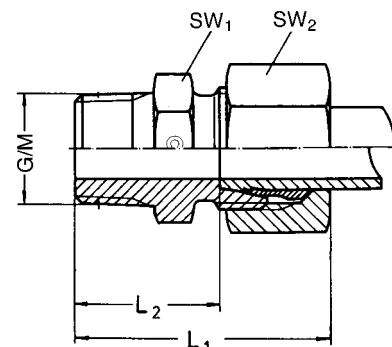

Seria DIN 2353 kg/100szt	PN bar	Rura śr. zewn.	Gwint zewn. DIN 2999 G	SW ₂	SW ₁	L ₁	L ₂	Kod	
BLL	100	• 4	R 1/8 keg.	10	10	25,5	16,0	GE 4-LLR 1/8 keg.	1,1
		• 6	R 1/8 keg.	12	11	26,0	14,5	GE 6-LLR 1/8 keg.	1,5
		• 8	R 1/8 keg.	14	14	28,0	16,5	GE 8-LLR 1/8 keg.	1,8
BL	315	• 6	R 1/8 keg.	14	12	30,5	16,0	GE 6-LR 1/8 keg.	2,5
		6	R 1/4 keg.	14	14	34,5	20,0	GE 6-LR 1/4 keg.	2,7
		• 8	R 1/4 keg.	17	17	35,0	20,0	GE 8-LR 1/4 keg.	4,0
		• 10	R 1/4 keg.	19	17	36,0	21,0	GE 10-LR 1/4 keg.	4,4
		• 10	R 3/8 keg.	19	19	36,0	21,0	GE 10-LR 3/8 keg.	5,7
		• 12	R 3/8 keg.	22	19	37,0	22,0	GE 12-LR 3/8 keg.	6,2
		• 12	R 1/2 keg.	22	22	39,0	24,0	GE 12-LR 1/2 keg.	8,0
		• 15	R 1/2 keg.	27	24	40,0	25,0	GE 15-LR 1/2 keg.	10,5
• 18	R 1/2 keg.	32	27	42,0	25,5	GE 18-LR 1/2 keg.	14,5		

Seria DIN 2353 kg/100szt	PN bar	Rura śr. zewn.	Gwint zewn. DIN 158 M	SW ₂	SW ₁	L ₁	L ₂	Kod	
ALL	100	• 4	M 8x1 keg.	10	10	25,5	16,0	GE 4-LLM 8x1 keg.	1,2
		• 6	M 10x1 keg.	12	11	26,0	14,5	GE 6-LLM 10x1 keg.	1,5
		• 8	M 10x1 keg.	14	12	28,0	16,5	GE 8-LLM 10x1 keg.	1,8
AL	315	• 6	M10x1 keg.	14	12	30,5	16,0	GE 6-LM 10x1 keg.	2,7
		6	M12x1,5 keg.	14	14	34,5	20,0	GE 6-LM 12x1,5 keg.	3,1
		• 8	M12x1,5 keg.	17	14	35,0	20,0	GE 8-LM 12x1,5 keg.	3,3
		8	M14x1,5 keg.	17	17	35,0	20,0	GE 8-LM 14x1,5 keg.	4,0
		• 10	M14x1,5 keg.	19	17	36,0	21,0	GE 10-LM 14x1,5 keg.	4,7
		• 10	M16x1,5 keg.	19	19	36,0	21,0	GE 10-LM 16x1,5 keg.	5,7
		• 12	M16x1,5 keg.	22	19	37,0	22,0	GE 12-LM 16x1,5 keg.	6,2
		• 12	M18x1,5 keg.	22	22	39,0	24,0	GE 12-LM 18x1,5 keg.	8,0
		• 15	M18x1,5 keg.	27	24	40,0	25,0	GE 15-LM 18x1,5 keg.	10,5
		• 18	M22x1,5 keg.	32	27	42,0	25,5	GE 18-LM 22x1,5 keg.	14,5

Wymiary są podane w przybliżeniu w zależności od stopnia dokręcenia nakrętek
• Zgodnie z DIN 3900