

Przyłączka prosta gwintowana
gwint cylindryczny

DIN 3901

DIN 2353 typ D

gwint BSPP równoległy

uszczelniany czołowo DIN 3852 - 2

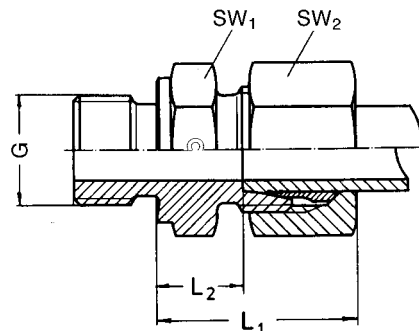

Seria DIN 2353	PN bar	Rura śr. zewn	ISO 1179-4/DIN-ISO 228-1 gw. zewn.				Kod	kg/100szt			
			G	SW ₂	SW ₁	L ₁			L ₂		
DL	315	• 6	G 1/8 A	14	14	23,0	8,5	GE 6-LR 1/8	2,5		
		6	G 1/4 A	14	19	24,5	10,0	GE 6-LR 1/4	4,0		
		6	G 3/8 A	14	22	26,0	11,5	GE 6-LR 3/8	5,8		
		6	G 1/2 A	14	27	26,5	12,0	GE 6-LR 1/2	10,0		
		8	G 1/8 A	17	17	23,5	8,5	GE 8-LR 1/8	3,2		
		• 8	G 1/4 A	17	19	25,0	10,0	GE 8-LR 1/4	4,3		
		8	G 3/8 A	17	22	26,0	11,5	GE 8-LR 3/8	5,9		
		8	G 1/2 A	17	27	26,5	12,0	GE 8-LR 1/2	9,9		
		10	G 1/8 A	19	19	25,5	10,5	GE 10-LR 1/8	4,3		
		• 10	G 1/4 A	19	19	26,0	11,0	GE 10-LR 1/4	5,0		
		10	G 3/8 A	19	22	27,5	12,5	GE 10-LR 3/8	6,4		
		10	G 1/2 A	19	27	29,0	14,0	GE 10-LR 1/2	10,2		
		12	G 1/8 A	22	19	25,5	10,5	GE 12-LR 1/8	*)		
		12	G 1/4 A	22	19	26,0	11,0	GE 12-LR 1/4	6,2		
		• 12	G 3/8 A	22	22	27,5	12,5	GE 12-LR 3/8	7,0		
		12	G 1/2 A	22	27	28,0	13,0	GE 12-LR 1/2	10,1		
		15	G 3/8 A	27	24	28,5	13,5	GE 15-LR 3/8	10,2		
		• 15	G 1/2 A	27	27	29,0	14,0	GE 15-LR 1/2	11,4		
		15	G 3/4 A	27	32	30,0	15,0	GE 15-LR 3/4	17,2		
		18	G 3/8 A	32	27	31,0	14,5	GE 18-LR 3/8	13,6		
		• 18	G 1/2 A	32	27	31,0	14,5	GE 18-LR 1/2	14,2		
		18	G 3/4 A	32	32	31,0	14,5	GE 18-LR 3/4	18,5		
			160	22	G 1/2 A	36	32	33,0	16,5	GE 22-LR 1/2	20,0
				• 22	G 3/4 A	36	32	33,0	16,5	GE 22-LR 3/4	19,6
				22	G1 A	36	41	34,0	17,5	GE 22-LR 1	28,9
				28	G 1/2 A	41	41	33,0	16,5	GE 28-LR 1/2	*)
				28	G 3/4 A	41	41	33,0	16,5	GE 28-LR 3/4	*)
				• 28	G1 A	41	41	34,0	17,5	GE 28-LR 1	27,0
28	G1 1/4 A			41	50	35,0	18,5	GE 28-LR 1 1/4	*)		
35	G 1/2 A			50	46	37,0	15,5	GE 35-LR 1/2	*)		
35	G 3/4 A			50	46	38,0	16,5	GE 35-LR 3/4	*)		
• 35	G1 A			50	46	38,0	16,5	GE 35-LR 1	*)		
35	G1 1/4 A			50	50	39,0	17,5	GE 35-LR 1 1/4	46,5		
35	G1 1/2 A			50	55	41,0	19,5	GE 35-LR 1 1/2	*)		
42	G1 A			60	55	39,0	16,0	GE 42-LR 1	*)		
42	G1 1/2 A			60	55	40,0	17,0	GE 42-LR 1 1/2	*)		
• 42	G1 1/2 A			60	55	42,0	19,0	GE 42-LR 1 1/2	61,0		

Wymiary są podane w przybliżeniu w zależności od stopnia dokręcenia nakrętek

• Zgodnie z DIN 3901

* Na zapytanie