

**Przyłączka kolankowa gwintowana  
gwint calowy stożkowy**

# CE S WE-R

**Przyłączka kolankowa gwintowana**  
gwint calowy stożkowy BSPT  
DIN 2353 typ G

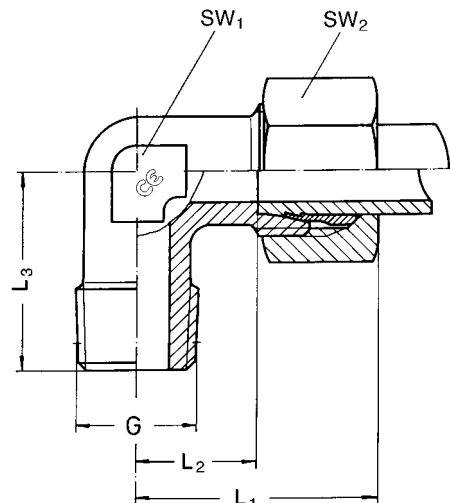

Seria DIN 2353	PN bar	Rura śr. zewn.	DIN 3858 gwint zewn. G	SW <sub>2</sub>	SW <sub>1</sub>	L <sub>1</sub>	L <sub>2</sub>	L <sub>3</sub>	Kod	kg/100szt
GLL	100	• 4	R 1/8 keg.	10	9	21,0	11,0	17	WE 4-LLR 1/8 keg.	2,1
		• 6	R 1/8 keg.	12	9	21,0	9,5	17	WE 6-LLR 1/8 keg.	2,7
		• 8	R 1/8 keg.	14	12	23,0	11,5	20	WE 8-LLR 1/8 keg.	3,2
GL	315	• 6	R 1/8 keg.	14	12	26,5	12,0	20	WE 6-LR 1/8 keg.	3,4
		6	R 1/4 keg.	14	12	26,5	12,0	24	WE 6-LR 1/4 keg.	5,7
		8	R 1/8 keg.	17	12	28,5	14,0	24	WE 8-LR 1/8 keg.	5,3
		• 8	R 1/4 keg.	17	12	28,5	14,0	26	WE 8-LR 1/4 keg.	6,0
		8	R 3/8 keg.	17	14	29,5	15,0	27	WE 8-LR 3/8 keg.	8,2
		8	R 1/2 keg.	17	19	31,5	17,0	30	WE 8-LR 1/2 keg.	9,5
		•10	R 1/4 keg.	19	14	29,5	15,0	27	WE 10-LR 1/4 keg.	5,5
		10	R 3/8 keg.	19	14	29,5	15,0	28	WE 10-LR 3/8 keg.	6,3
		10	R 1/2 keg.	19	19	29,5	15,0	30	WE 10-LR 1/2 keg.	9,0
		12	R 1/4 keg.	22	17	32,0	17,0	28	WE 12-LR 1/4 keg.	7,4
		•12	R 3/8 keg.	22	17	32,0	17,0	28	WE 12-LR 3/8 keg.	7,5
		12	R 1/2 keg.	22	19	36,0	21,0	32	WE 12-LR 1/2 keg.	11,0
		•15	R 1/2 keg.	27	19	36,0	21,0	34	WE 15-LR 1/2 keg.	13,4
		•18	R 1/2 keg.	32	24	40,0	23,5	36	WE 18-LR 1/2 keg.	19,0
GS	630	• 6	R 1/4 keg.	17	12	31,0	16,0	26	WE 6-SR 1/4 keg.	4,9
		6	R 3/8 keg.	17	14	31,0	16,0	26	WE 6-SR 3/8 keg.	*)
		6	R 1/2 keg.	17	17	31,0	16,0	28	WE 6-SR 1/2 keg.	*)
		• 8	R 1/4 keg.	19	14	32,0	17,0	27	WE 8-SR 1/4 keg.	6,9
		8	R 3/8 keg.	19	14	32,0	17,0	27	WE 8-SR 3/8 keg.	7,9
		8	R 1/2 keg.	19	17	32,0	17,0	30	WE 8-SR 1/2 keg.	10,2
		10	R 1/4 keg.	22	17	34,0	17,5	28	WE 10-SR 1/4 keg.	9,2
		•10	R 3/8 keg.	22	17	34,0	17,5	28	WE 10-SR 3/8 keg.	9,5
		10	R 1/2 keg.	22	19	34,0	17,5	31	WE 10-SR 1/2 keg.	13,1
		•12	R 3/8 keg.	24	17	38,0	21,5	28	WE 12-SR 3/8 keg.	11,5
		12	R 1/2 keg.	24	18	38,0	21,5	31	WE 12-SR 1/2 keg.	13,0
		14	R 3/8 keg.	27	19	40,0	22,0	31	WE 14-SR 3/8 keg.	14,7
		•14	R 1/2 keg.	27	19	40,0	22,0	32	WE 14-SR 1/2 keg.	15,8
	400	•16	R 1/2 keg.	30	24	43,0	24,5	32	WE 16-SR 1/2 keg.	20,0

Wymiary są podane w przybliżeniu w zależności od stopnia dokręcenia nakrętek

• Zgodnie z DIN 3903

\* Na zapytanie