

**Przyłączka kolankowa gwintowana  
gwint NPT**

# CE S WE-NPT

**Przyłączka kolankowa gwintowana**  
gwint calowy stożkowy NPT  
ANSI/ASME B 1.1 - 1983

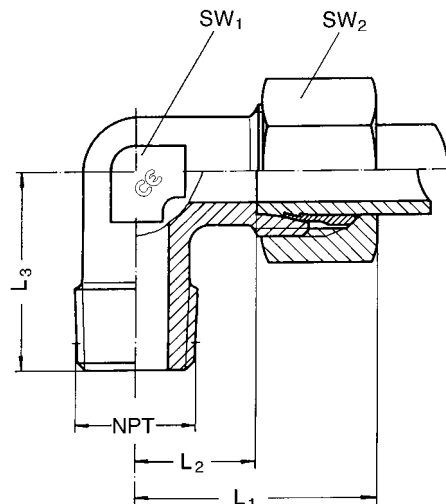

Seria DIN 2353	PN bar	Rura śr. zewn.	gwint zewn. NPT	SW <sub>2</sub>	SW <sub>1</sub>	L <sub>1</sub>	L <sub>2</sub>	L <sub>3</sub>	Kod	kg/100szt
LL	100	4	1/8 NPT	10	9	21	11,0	17	WE 4-LL 1/8 NPT	2,0
		6	1/8 NPT	12	9	21	9,5	17	WE 6-LL 1/8 NPT	2,3
		8	1/8 NPT	14	12	23	11,5	20	WE 8-LL 1/8 NPT	3,3
L	315	6	1/8 NPT	14	12	27	12,0	20	WE 6-L 1/8 NPT	4,2
		6	1/4 NPT	14	12	27	12,0	26	WE 6-L 1/4 NPT	4,5
		6	3/8 NPT	14	14	27	12,0	28	WE 6-L 3/8 NPT	6,0
		8	1/8 NPT	17	12	29	14,0	24	WE 8-L 1/8 NPT	6,7
		8	1/4 NPT	17	12	29	14,0	26	WE 8-L 1/4 NPT	6,7
		10	1/4 NPT	19	14	30	15,0	27	WE 10-L 1/4 NPT	8,5
		10	3/8 NPT	19	14	32	17,0	28	WE 10-L 3/8 NPT	9,8
		12	1/4 NPT	22	17	32	17,0	28	WE 12-L 1/4 NPT	11,4
		12	3/8 NPT	22	17	32	17,0	28	WE 12-L 3/8 NPT	12,0
		12	1/2 NPT	22	19	32	17,0	34	WE 12-L 1/2 NPT	13,1
	15	1/2 NPT	27	19	36	21,0	34	WE 15-L 1/2 NPT	14,4	
	18	1/2 NPT	32	24	40	23,5	36	WE 18-L 1/2 NPT	17,1	
	160	22	3/4 NPT	36	27	44	27,5	42	WE 22-L 3/4 NPT	23,7
		28	1 NPT	41	36	47	30,5	48	WE 28-L 1 NPT	38,4
		35	1 1/4 NPT	50	41	56	34,5	54	WE 35-L 1 1/4 NPT	58,7
42		1 1/2 NPT	60	50	63	40,0	61	WE 42-L 1 1/2 NPT	84,5	
S	630	6	1/4 NPT	17	12	31	16,0	26	WE 6-S 1/4 NPT	7,1
		6	3/8 NPT	17	14	31	16,0	28	WE 6-S 3/8 NPT	8,2
		6	1/2 NPT	17	19	31	16,0	33	WE 6-S 1/2 NPT	9,9
		8	1/4 NPT	19	14	32	17,0	27	WE 8-S 1/4 NPT	9,9
		8	3/8 NPT	19	14	32	17,0	28	WE 8-S 3/8 NPT	10,7
		8	1/2 NPT	19	19	32	17,0	33	WE 8-S 1/2 NPT	13,3
		10	1/4 NPT	22	17	34	17,5	27	WE 10-S 1/4 NPT	13,7
		10	3/8 NPT	22	17	34	17,5	28	WE 10-S 3/8 NPT	14,9
		12	1/4 NPT	24	17	38	21,5	27	WE 12-S 1/4 NPT	16,6
		12	3/8 NPT	24	17	38	21,5	28	WE 12-S 3/8 NPT	17,3
	12	1/2 NPT	24	19	38	21,5	33	WE 12-S 1/2 NPT	19,7	
	14	3/8 NPT	27	19	40	22,0	28	WE 14-S 3/8 NPT	16,9	
	14	1/2 NPT	27	19	40	22,0	34	WE 14-S 1/2 NPT	17,5	
	400	16	1/2 NPT	30	24	43	24,5	34	WE 16-S 1/2 NPT	19,8
		20	3/4 NPT	36	27	48	26,5	42	WE 20-S 3/4 NPT	31,1
25		1 NPT	46	36	54	30,0	48	WE 25-S 1 NPT	57,0	
30		1 1/4 NPT	50	41	62	35,5	54	WE 30-S 1 1/4 NPT	82,9	
315	38	1 1/2 NPT	60	50	72	41,0	61	WE 38-S 1 1/2 NPT	117,5	

Wymiary są podane w przybliżeniu w zależności od stopnia dokręcenia nakrętek