

**Przyłączka redukcyjna serii S (ciężka)
z zaciętym jednostronnie pierścieniem**

CE S KOR-S

Przyłączka redukcyjna
Seria S
z zaciętym jednostronnie pierścieniem

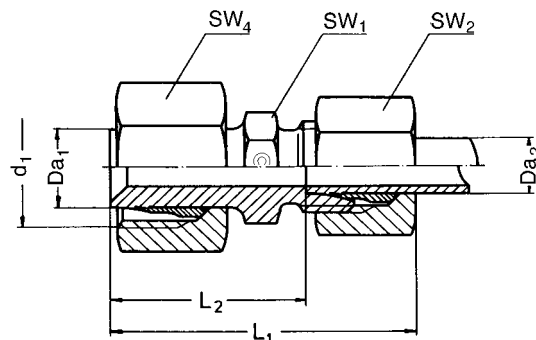

Seria	PN bar	Rura śr. zewn.		d ₁	L ₁	L ₂	SW ₄	SW ₁	SW ₂	Kod	kg/100szt	
		Da ₁	Da ₂									
S	630	8	6	M 16x1,5	44,0	29,0	19	14	17	KOR 8/ 6-S	5,4	
		10	6	M 18x1,5	46,5	31,5	22	14	17	KOR 10/ 6-S	6,9	
		10	8	M 18x1,5	48,5	33,5	22	17	19	KOR 10/ 8-S	7,5	
		12	6	M 20x1,5	46,0	31,0	24	14	17	KOR 12/ 6-S	7,8	
		12	8	M 20x1,5	48,0	33,0	24	17	19	KOR 12/ 8-S	8,4	
		12	10	M 20x1,5	48,5	32,5	24	19	22	KOR 12/10-S	9,6	
		14	6	M 22x1,5	50,0	35,0	27	17	17	KOR 14/ 6-S	10,3	
		14	8	M 22x1,5	50,0	35,0	27	17	17	KOR 14/ 8-S	10,8	
		14	10	M 22x1,5	50,5	34,5	27	19	22	KOR 14/10-S	12,0	
		14	12	M 22x1,5	52,5	36,5	27	22	24	KOR 14/12-S	12,7	
		400	16	6	M 24x1,5	51,0	36,0	30	17	17	KOR 16/ 6-S	12,3
			16	8	M 24x1,5	51,0	36,0	30	17	19	KOR 16/ 8-S	12,8
	16		10	M 24x1,5	51,5	35,5	30	19	22	KOR 16/10-S	14,4	
	16		12	M 24x1,5	53,5	37,5	30	22	24	KOR 16/12-S	15,1	
	16		14	M 24x1,5	57,0	39,0	30	24	27	KOR 16/14-S	16,9	
	20		6	M 30x2	56,5	41,5	36	22	17	KOR 20/ 6-S	18,7	
	20		8	M 30x2	56,5	41,5	36	22	19	KOR 20/ 8-S	20,0	
	20		10	M 30x2	57,0	41,0	36	22	22	KOR 20/10-S	21,0	
	20		12	M 30x2	57,0	41,0	36	22	24	KOR 20/12-S	21,7	
	20		14	M 30x2	60,5	42,5	36	24	27	KOR 20/14-S	23,4	
	20		16	M 30x2	60,5	42,0	36	27	30	KOR 20/16-S	25,2	
	25		6	M 36x2	59,0	44,0	46	27	17	KOR 25/ 6-S	*)	
	25		8	M 36x2	59,0	44,0	46	27	19	KOR 25/ 8-S	*)	
	25		10	M 36x2	59,5	43,5	46	27	22	KOR 25/10-S	35,2	
	25		12	M 36x2	59,5	43,5	46	27	24	KOR 25/12-S	35,9	
	25		14	M 36x2	63,0	45,0	46	27	27	KOR 25/14-S	37,1	
	25		16	M 36x2	63,0	44,5	46	27	30	KOR 25/16-S	38,7	
	25		20	M 36x2	68,0	46,5	46	32	36	KOR 25/20-S	44,8	
	30		6	M 42x2	63,5	48,5	50	32	17	KOR 30/ 6-S	*)	
	30		8	M 42x2	63,5	48,5	50	32	19	KOR 30/ 8-S	40,3	
	30		10	M 42x2	64,0	48,0	50	32	22	KOR 30/10-S	41,8	
	30		12	M 42x2	64,0	48,0	50	32	24	KOR 30/12-S	41,1	
	30		14	M 42x2	67,5	49,5	50	32	27	KOR 30/14-S	*)	
30	16		M 42x2	67,5	49,0	50	32	30	KOR 30/16-S	46,2		
30	20	M 42x2	70,5	49,0	50	32	36	KOR 30/20-S	50,5			
30	25	M 42x2	75,5	51,5	50	41	46	KOR 30/25-S	63,2			
315	38	6	M 52x2	69,5	54,5	60	41	17	KOR 38/ 6-S	*)		
	38	8	M 52x2	69,5	54,5	60	41	19	KOR 38/ 8-S	*)		
	38	10	M 52x2	70,0	54,0	60	41	22	KOR 38/10-S	61,5		
	38	12	M 52x2	70,0	54,0	60	41	24	KOR 38/12-S	58,5		
	38	14	M 52x2	73,5	55,5	60	41	27	KOR 38/14-S	*)		
	38	16	M 52x2	73,5	55,0	60	41	30	KOR 38/16-S	62,3		
	38	20	M 52x2	76,5	55,0	60	41	36	KOR 38/20-S	71,9		
	38	25	M 52x2	79,5	55,5	60	41	46	KOR 38/25-S	82,5		
	38	30	M 52x2	82,5	56,0	60	46	50	KOR 38/30-S	85,9		

Wymiary są podane w przybliżeniu w zależności od stopnia dokręcenia nakrętek
* Na zapytanie