

## Przyłączka typu Banjo wysokociśnieniowa

gwint:

całowy, cylindryczny BSP

z uszczelnieniem:

uszczelka miękka(NBR, Viton) - WD

czołowe - DKA

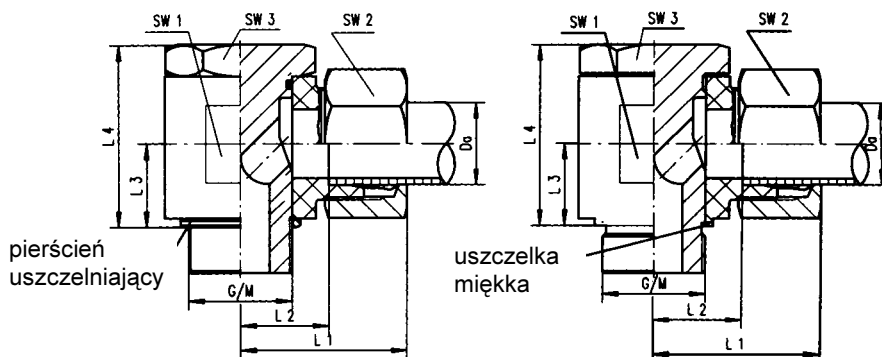

Seria	PN bar	Rura śr. zewn.		SW <sub>2</sub>	SW <sub>3</sub>	SW <sub>1</sub>	L <sub>1</sub>	L <sub>2</sub>	L <sub>3</sub>	L <sub>4</sub>	Kod	kg/ 100szt
		Da	G									
L	315	6	G 1/8A	14	17	17	27	12,0	8,5	22,5	WH 6-LR	6,9
		8	G 1/4A	17	19	22	29	14,5	11,5	29,0	WH 8-LR	11,7
		10	G 1/4A	19	19	22	30	15,5	14,0	30,0	WH 10-LR	14,0
		12	G 3/8A	22	24	27	33	18,0	14,0	35,5	WH 12-LR	19,1
		15	G 1/2A	27	30	32	37	21,5	20,5	47,4	WH 15-LR	32,0
		18	G 1/2A	32	30	32	37	21,0	20,5	47,4	WH 18-LR	38,0
	160	22	G 3/4A	36	36	41	44	27,5	23,0	54,0	WH 22-LR	64,1
		28	G1 A	41	46	50	49	32,0	30,5	66,0	WH 28-LR	89,0
		35	G1 1/4A	50	55	60	58	36,0	35,5	76,0	WH 35-LR	148,0
		42	G1 1/2A	60	60	70	63	40,5	40,5	87,0	WH 42-LR	236,7
S	400	6	G 1/4A	17	19	22	31	16,5	14,0	30,0	WH 6-SR	12,0
		8	G 1/4A	19	19	22	31	16,5	14,0	30,0	WH 8-SR	14,8
		10	G 3/8A	22	24	27	35	18,5	14,0	35,5	WH 10-SR	20,0
		12	G 3/8A	24	24	27	35	18,5	14,0	35,5	WH 12-SR	20,6
		14	G 1/2A	27	30	32	40	22,5	21,5	45,0	WH 14-SR	32,3
		16	G 1/2A	30	30	32	40	22,5	21,5	45,0	WH 16-SR	38,3
		20	G 3/4A	36	36	41	48	26,5	24,0	53,0	WH 20-SR	72,3
	250	25	G1 A	46	46	50	56	31,5	30,5	66,0	WH 25-SR	101,7
		30	G1 1/4A	50	55	60	64	37,0	35,5	76,0	WH 30-SR	161,3
		38	G1 1/2A	60	60	70	72	41,5	40,5	87,0	WH 38-SR	250,5

Gwint metryczny, cylindryczny

Seria	PN bar	Rura śr. zewn. DIN 13		SW <sub>2</sub>	SW <sub>3</sub>	SW <sub>1</sub>	L <sub>1</sub>	L <sub>2</sub>	L <sub>3</sub>	L <sub>4</sub>	Kod	kg/ 100szt
		Da	M <sub>1</sub>									
L	315	6	M 10x1	14	17	17	27	12,0	8,5	22,0	WH 6-LM	6,7
		8	M 12x1,5	17	19	22	29	14,5	11,5	29,0	WH 8-LM	11,7
		10	M 14x1,5	19	19	22	30	15,5	11,5	29,0	WH 10-LM	14,1
		12	M 16x1,5	22	24	27	33	18,0	14,0	35,5	WH 12-LM	19,0
		15	M 18x1,5	27	30	32	36	20,5	16,5	39,5	WH 15-LM	26,8
		18	M 22x1,5	32	30	32	37	21,0	20,5	47,0	WH 18-LM	35,3
	160	22	M 26x1,5	36	36	41	44	27,5	24,0	53,0	WH 22-LM	49,1
		28	M 33x2	41	46	50	49	32,0	30,5	66,0	WH 28-LM	90,8
		35	M 42x2	50	55	60	58	36,0	35,5	76,0	WH 35-LM	149,0
		42	M 48x2	60	60	70	63	40,5	40,5	87,0	WH 42-LM	236,7
S	400	6	M 12x1,5	17	19	22	31	16,5	14,0	30,0	WH 6-SM	12,1
		8	M 14x1,5	19	19	22	31	16,5	14,0	30,0	WH 8-SM	14,9
		10	M 16x1,5	22	24	27	35	18,5	16,5	36,0	WH 10-SM	19,8
		12	M 18x1,5	24	30	32	36	20,0	16,5	39,5	WH 12-SM	28,2
		14	M 20x1,5	27	30	32	40	22,5	16,0	43,5	WH 14-SM	33,1
		16	M 22x1,5	30	30	32	40	22,0	20,5	47,0	WH 16-SM	35,7
		20	M 27x2	36	36	41	48	26,5	24,0	53,0	WH 20-SM	71,0
	250	25	M 33x2	46	46	50	56	31,5	30,5	66,0	WH 25-SM	103,6
		30	M 42x2	50	55	60	64	37,0	35,5	76,0	WH 30-SM	162,3
		38	M 48x2	60	60	70	72	41,5	40,5	87,0	WH 38-SM	250,5

Wymiary są podane w przybliżeniu w zależności od stopnia dokręcenia nakrętek