



THE PREMIUM QUALITY



Dk-Lok[®] Tube Fittings











Catalog Number 01-5
March, 2009





Dk Tech Corporation

www.dklok.com

Tube to Tube Union







Union DU		11
Union Elbow DL		12
Union Tee DT		13
Union Cross DX		14
Bulkhead Union DUB		15
Bulkhead Retainer DBR		16
Bulkhead Elbow Union DBL		16
Reducing Union DUR		17
Reducing Union Elbow DLR		18
Reducing Union Cross DXR		18
Reducing Union Tee DTR		19,20











Tube to Male Pipe

Male Connector DMC-N		21,22
Male Connector DMC-R		23,24

Thermocouple Connector DMCT		23
Male Connector for Bonded Gasket Seal DMC-G		25
Male Connector for Metal Gasket DMC-GB		25,26
Bulkhead Male Connector DMCB-N		28,29
45° Male Elbow DLBM		29
Male Elbow DLM-N		30,31
Male Elbow DLM-R		32,33
Male Run Tee DTRM-N		34
Male Run Tee DTRM-R		35
Male Branch Tee DTBM-N, -R		36
Male Branch Tee DTBM-N		37
Male Branch Tee DTBM-R		38

Tube to Female Pipe

Female Connector DCF-N		39,40
Female Connector DCF-R		41
Gauge Connector DCF-GG		42
Bulkhead Female Connector DCBF-N		43
Female Elbow DLF-N		44
Female Run Tee DTRF-N		45
Female Branch Tee DTBF-N		46

Tube Stub Connector		
Reducer DR		47,48
Bulkhead Adapter DAB		49
Male Adapter DAM-N		49,50
Male Adapter DAM-R		51
Male Adapter DAM-G		52
Male Adapter DAM-U		53
Male Adapter DAM-UO		53
Female Adapter DAF-N		54
Female Adapter DAF-R		55
Female Adapter DAF-GR		55

Female Gauge Adapter
DAF-GG  56

Elbow Adapter
DLA  57

Run Tee Adapter
DTRA  57

Branch Tee Adapter
DTBA  57

Port Connector
DCP  58

Reducing Port Connector
DCRP  59

Dk-Lok Flanges

Dk-Lok Flanges
DF  59,60

Lab Joint
Flange Connector
DLJ  60

Tube to AN Tube

AN Union
DUA  61

AN Bulkhead Union
DUBA  61

Male AN Adapter
DMAA  62

AN Adapter
DAA  62

**Tube to Non-Positionable
O-seal End**

O-Seal Straight
Thread Connector
DMC-UO  63

O-Seal Pipe
Thread Connector
DMC-NO  63

Non-Positionable SEA
Male Connector
DMCS-U  64

**Tube to Positionable
Straight Thread**

Positionable SAE
Male Elbow
DLS-UP  65

Positionable
45° SAE Male Elbow
DLBS-UP  66

Positionable
SAE Male Run Tee
DTRS-UP  66

Positionable
SAE Male Branch Tee
DTBS-UP  66

Positionable Male Elbow
ISO Parallel Thread
DLM-GP  67

Tube to Weld End

Male Pipe
Weld Connector
DCW  68

Male Pipe
Weld Elbow
DLW  69

Tube Socket
Weld Connector
DCSW  69

Tube Socket
Weld Elbow
DLSW  70

Welding Bulkhead
Union
DBUW  70

Plug, Cap, Insert

Plug
DP  70

Cap
DC  71

Tube Insert
DI  72

Additional Products

Fuse Plug
DFA  72

Vent Protector
DMD  73

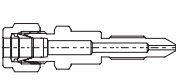
Calibration
Fittings
DPCM  73

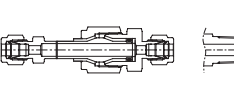
Dielectric
Fittings
DEU  74

Spare Parts

Nut
DN  75

Ferrule Set
DFS  75

Nut-Ferrule Set
DFSN  75

Front Ferrule
DFF  76

Back Ferrule
DFB  76

Tools

Preswaging Tool
DPS  76

Gap Gauge
DIG  77

Tube Depth
Marking Tool
DTM  77

Pre-Swaging Unit
DHS-2A  77

Pre-Swaging Unit
DES-1A  77

The Premium Quality Dk-Lok Tube Fittings

Dk-Lok Tube Fitting is designed using industrial codes and specifications with additional Cutting-Edge Engineering on swaging action and sealing integrity. Dk-Lok provides excellent leak-free sealing on high pressure gas, vacuum, impulse, thermal shock, heavy vibration, and many other stringent applications.

Dk-Lok brings you excellent quality, outstanding customer service, and availability. Enjoy Dk-Lok tube fitting working on your application!

Construction of Dk-Lok Tube Fittings

Dk-Lok Tube Fitting consists of body, front ferrule, back ferrule and nut. The features include;

- Excellent product range up to 2 in. and 38 mm OD.
- Additional engineering on sealing integrity and swaging action.
- Re-usable and predictable quality.
- Gaugable.
- Excellent leak-free sealing integrity on heavy vibration, vacuum and impulse.
- Heat-Code Traceability.
- No torque transferring to connective tubing during installation.

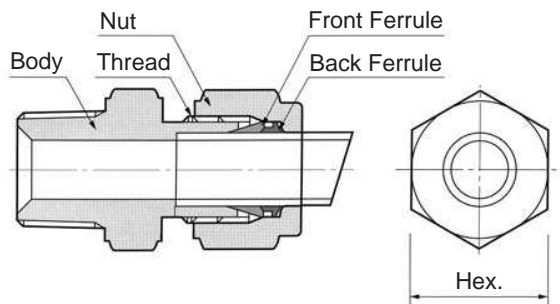

Identification of Metric Dk-Lok Tube Fitting

Metric Dk-Lok tube fitting has stepped shoulder on body and nut hex. Shaped fitting body such as tee, elbow, and cross forging has no such step.

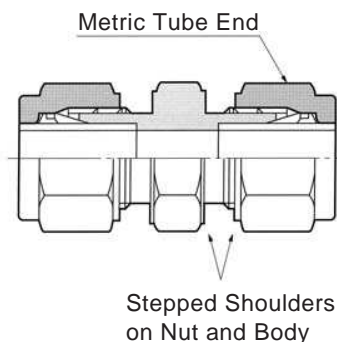

Dk-Lok Material Standards

Dk-Lok tube fitting are supplied in various materials to satisfy the needs of various applications including on shore oil & gas, refinery, offshore oil & gas, chemical, petrochemical, analytical instrumentation, steel mill, power plant, shipbuilding, pharmaceutical, and alternative fuel.

Table 1.

Material	Bar Stock	Forging
Stainless Steel 316	ASTM A276 Type 316	ASTM A182
	ASTM A479 Type 316	ASME SA182
	ASME SA479 Type 316	JIS G3214
	JIS G4303	
Brass	ASTM B16 UNS C36000	ASTM B283 Alloy 37700
	ASTM B453 UNS C35300	JIS H3250 Alloy C3771
	JIS H3250 Alloy C3604	
Carbon Steel	ASTM A108	ASTM A105
	JIS G4051 S20C - S48C	JIS G4051 S20C - S48C
Duplex	ASTM A276 S31803	ASTM A182 F51
	ASTM A479 S31803	
Super Duplex	ASTM A479 S32750	ASTM A182 F51
Aluminum	ASTM B211 Alloy 2024 T6	ASTM B247
	Alloy 20	ASTM B473 UNS N08020
Hastelloy C276	ASTM B574 UNS N10276	ASTM B564 UNS N10276
	Alloy 400	ASTM B164 UNS N04400
Alloy 600	ASTM B166 UNS N06600	ASTM B564 UNS N06600
	Alloy 625	ASTM B446 UNS N06625
Alloy 825	ASTM B425 UNS N08825	ASTM B564 UNS N08825
	Titanium Gr.2	ASTM B348 Gr.2
PTFE	ASTM D1710	ASTM D3293

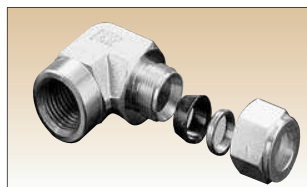

Carbon Steel Dk-Lok Tube Fittings

Carbon steel fittings are white zinc plated. Every carbon steel fitting is supplied with SS316 back ferrule.

Product Cleaning

Every Dk-Lok tube fitting is cleaned to remove surface contamination, iron particles from cutting tools, oil from cutting fluid, and loose particles. For further information, refer to DK cleaning standard DC-01. Special cleaning for oxygen service application is available on request. Refer to special cleaning standard DC-11.

O-ring

Dk-Lok fitting pipe end with O-ring is supplied; 70 durometer NBR O-ring on Brass and Carbon steel fittings, 90 durometer FKM O-ring on Stainless steel fitting. Other O-ring is available on request.

Dk-Lok Port Dimension

Dimensions on Dk-Lok Port in the catalog are approximate figures and shown in finger-tight position.

Alternative Fuels

Stainless steel 316 Dk-Lok tube fitting are tested to the requirements of ECE R110, EIHP Draft, ECE R67 and certified by TUV.

Tubing

For safe, reliable and leak-free Dk-Lok fitting system, tubing should be considered as one of fitting components.

- Tubing is assembled by simple wrench make-up on Dk-Lok fitting. This results in less assembly and maintenance costs.
- Tubing assembly on Dk-Lok fitting is re-usable.
- Tubing is bendable. It allows lower pressure drop with fewer connections. This in turn reduces system costs because of less fabricating manpower.
- Pipe threading or welding is difficult to disassemble and re-assemble.
- Piping requires skilled worker for welding & threading.

1. Tubing Selection
2. Tubing Handling

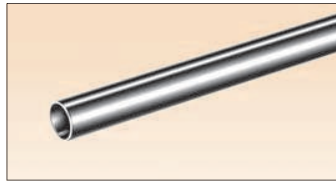

1. Tubing Selection

Hardness

- Tubing must be softer than fitting material. The metal tubing must be fully annealed and suitable for bending and flaring.
- Tubing hardness must be selected according to the information in the table 2 to 13.

Surface

- Tubing must have a surface free from scratches, draw mark, dirt, dust and flat spots.

Ovality

- Tubing in oval or out-of-roundness may not fit into the fitting. Do not force the tubing into the fitting; it may damage the fitting sealing system on nut, ferrules, and body.

Wall thickness

- The table 2 to 13 list tubing working pressure ratings in a wide range of wall thickness. A too thin wall may collapse and a too thick wall may not properly be deformed by the ferrule action.
- Do not use tubing wall thickness not listed in the table 2 to 13.

Weld tubing

- Welded tubing should have a not measurable bead on its outside diameter.

2. Tubing Handling

Careful handling and storage practices will protect tubing from unnecessary scratches, nicks, or degrading the good tubing surface finish.

- Tubing ends should be capped so any foreign materials will not fall inside during transportation and storage.
- Do not drag across tubing rack, cement, gravel or any rough surface.
- Do use correct tube cutter for tube material. The wrong cutter may result in excessive deformation of the tube end.
- Do not cut deep with each turn of cutting.
- Tube cutters and hacksaws should be sharp enough.
- Hacksaw blades should have at least 32 teeth per inch.
- Do deburr tube ends before inserting in fittings.

Dk-Lok Tube Fitting Pressure Rating

The pressure rating of Dk-Lok Tube Fitting is rated to the working pressure of connective tubing.

The allowable working pressure of tubing in various materials is listed in the table 2 to 13.

Material

Using like tubing and fitting material is essential for leak-free sealing system.

Unlike material may have different mechanical properties that may adversely affect the fitting seal on tubing.

The only exception is copper tubing with brass Dk-Lok fitting.

Gas Application

Dk-Lok tube fitting is designed for a wide range of leak-free application including gas leak proof and vacuum tight service. Gases (helium, hydrogen, nitrogen, air, etc.) can escape even the most minute leak-path due to their very small molecules. Tube therefore must be handled not to have scratches, draw mark, nicks, flat spots, dirt, and dust.

Use NOT thin wall tubing for gas applications.

Heavier wall tubing resists the ferrule action whereas thin wall tubing may collapse with little resistance to ferrule action.

For Gas service, use the tubing wall listed on un-shadowed section in table 2 to 13.

Vacuum Application

Dk-Lok tube fittings have been proved to be excellent vacuum tight seal in many applications including analytical industry.

Dk-Lok Tube Fittings comply with the leakage requirements of TA-LUFT 2002.

Cryogenic Application

Dk-Lok Fittings in SS316 Stainless Steel provide highly reliable performance on cryogenic application.

Cryogenic temperature is considered to be temperatures below -100°F (-73°C).

High Pressure Application

Gas pressure 500 psig (34.5 bar) or higher is considered generally high pressure. In the high pressure system scratches, draw mark, nicks, flat spots, and dirt on tubing may cause leakage.

- For gas application, select the gas applicable tubing wall thickness from Table 2 to 13.
- Follow the suggestion on tubing selection, handling, and installation.

Dk-Lok Tube Fittings

Table 2. Fractional Seamless Stainless Steel Tubing

Fully annealed austenitic Type 304 or 316 seamless tubing ASTM A269 or ASTM A213, or equivalent. Tubing to be free from scratches, draw mark, dirt, dust, flat spots, and suitable for bending and flaring. Recommended hardness: 80 HRB or less.

OD in.	Wall Thickness (in.)														
	0.012	0.014	0.016	0.020	0.028	0.035	0.049	0.065	0.083	0.095	0.109	0.120	0.134	0.156	0.188
1/16	6,800	8,100	9,400	12,000											
1/8					8,500	10,900									
3/16					5,400	7,000	10,200								
1/4					4,000	5,100	7,500	10,200							
5/16						4,000	5,800	8,000							
3/8						3,300	4,800	6,500	8,600						
1/2						2,400	3,500	4,700	6,200						
5/8							2,900	4,000	5,200	6,000					
3/4							2,400	3,300	4,200	4,900	5,800	6,400			
7/8							2,000	2,800	3,600	4,200	4,800	5,400	6,100		
1								2,400	3,100	3,600	4,200	4,700	5,300	6,200	
1 1/4									2,400	2,800	3,300	3,600	4,100	4,900	
1 1/2										2,300	2,700	3,000	3,400	4,000	4,900
2											2,000	2,200	2,500	2,900	3,600

Table 3. Metric Seamless Stainless Steel Tubing

OD mm	Wall Thickness (mm)													
	0.8	1.0	1.2	1.5	1.8	2.0	2.2	2.5	2.8	3.0	3.5	4.0	4.5	
3	710													
6	330	420	520	670										
8		310	380	490										
10		240	300	380										
12		200	240	310	380	430								
14		180	220	280	340	390	430							
15		170	200	260	320	360	400							
16			190	240	300	330	370							
18			170	210	260	290	320	370						
20			150	190	230	260	290	330	380					
22			130	170	210	230	260	300	340					
25				180	200	230	260	300	320					
28					180	200	230	260	280	330				
30						170	190	210	240	260	310			
32							160	170	200	230	240	290	330	
38								140	170	190	200	240	280	310

- Tubing allowable working pressure is calculated at -20 to 100°F (-28 to 37°C) using allowable stress value of 20,000 psi according to ASME B31.3 Process Piping Code.
- Pressure calculations are based on **maximum O.D. and minimum wall thickness** and no allowance is made for corrosion and erosion. i.e., ASTM A269 1/2 in. OD x 0.035 in.WT: OD tolerance ± 0.005 in., WT tolerance ± 15%. Calculations are based on 0.505 in.OD x 0.0298 in. WT.
- Safety Factor is 3.75 to 1, considering ultimate tensile strength of 75,000 psi.
- To determine working pressure of ASME B31.1 Power Piping Code, multiply the ASME 31.3 rating by 0.94.

Weld Stainless Steel Tubing Allowable Working Pressure

To determine the working pressure of weld tubing to the requirements of ASME B31.3 Code, de-rating factors below must be applied. For single weld tubing multiply by 0.80, and for double weld tubing multiply by 0.85.

Example: SS316 seamless 1/2 in. O.D. x 0.065 in. WT allowable working pressure: 4700 psi.
 To determine the work pressure of the single weld tubing, multiply 4700 psi by 0.80.
 4700 psig x 0.80 = 3760 psig at -20 to 100°F (-28 to 37°C).

Table 4. Fractional Seamless Copper Tubing

Soft annealed seamless copper tubing ASME B75 or equivalent. Soft annealed (Temper 0) copper water tube, type K or Type L ASTM B88. Recommended hardness: 60 HRB or less.

OD in.	Wall Thickness (in.)											
	0.010	0.012	0.028	0.035	0.049	0.065	0.083	0.095	0.109	0.120		
1/8			2,700	3,600								
3/16			1,800	2,300	3,400							Working Pressure in PSIG
1/4			1,300	1,600	2,500	3,500						
5/16				1,300	1,900	2,700						
3/8				1,000	1,600	2,200						
1/2				800	1,100	1,600	2,100					
5/8					900	1,200	1,600	1,900				
3/4					700	1,000	1,300	1,500	1,800			
7/8					600	800	1,100	1,300	1,500			
1					500	700	900	1,100	1,300	1,500		

Table 5. Metric Seamless Copper Tubing

OD mm	Wall Thickness (mm)											
	0.7	0.8	1.0	1.2	1.5	1.6	1.8	2.0	2.2	2.5	3.0	
3	225	260										
4	165	191	244	295								Working Pressure in Bar
6		122	157	192	245	263						
8		89	114	140	179	193						
10		70	89	109	140	150	172	193				
12		58	73	89	114	123	140	158				
14			62	76	96	103	118	133	148	171	209	
16			54	66	83	89	102	114	127	147	180	
18			48	58	74	79	90	101	112	129	159	
22			39	47	59	64	72	81	90	103	126	
25			34	41	52	56	63	71	78	90	110	

- Allowable working pressure calculated at -20 to 100°F (-28 to 37°C) using S value of 6,000 psi according to ASME B31.3 Code.
- Safety Factor is 5 to 1, considering ultimate tensile strength of 30,000 psi.

Table 6. Fractional Seamless Carbon Steel Tubing

Soft annealed seamless carbon steel hydraulic tubing ASTM A179 or equivalent. Tubing to be free from scratches, draw mark, dirt, dust, flat spots, and suitable for bending and flaring. Recommended hardness: 72 HRB or less.

OD in.	Wall Thickness (in.)												
	0.028	0.035	0.049	0.065	0.083	0.095	0.109	0.120	0.134	0.148	0.165	0.180	0.220
1/8	8,000	10,200											
3/16	5,100	6,600	9,600										
1/4	3,700	3,700	7,000	9,600									Working Pressure in PSIG
5/16		3,800	5,500	7,600									
3/8		3,100	4,500	6,200									
1/2		2,300	3,300	4,500	5,900								
5/8		1,800	2,600	3,500	4,600	5,300							
3/4			2,100	2,900	3,700	4,300	5,100						
7/8			1,800	2,400	3,200	3,700	4,300						
1			1,500	2,100	2,700	3,200	3,700	4,100					
1 1/4				1,600	2,100	2,500	2,900	3,200	3,600	4,000	4,600	5,000	
1 1/2					1,800	2,000	2,400	2,600	3,000	3,300	3,700	4,100	5,100
2						1,500	1,700	1,900	2,200	2,400	2,700	3,000	3,700

Dk-Lok Tube Fittings

Table 7. Metric Seamless Carbon Steel Tubing

OD mm	Wall Thickness (mm)												
	0.8	1.0	1.2	1.5	1.8	2.0	2.2	2.5	2.8	3.0	3.5	4.0	4.5
3	670	830											
6	310	400	490	630									
8		290	360	460									
10		230	280	360									
12		190	230	290	360	410	450						
14		160	190	250	300	340	380						
15		150	180	230	280	320	350						
16			170	210	260	290	330	380					
18			150	190	230	260	290	330					
20			130	170	200	230	250	290	330				
22			120	150	180	210	230	260	300				
25					160	180	200	230	260	280			
28						160	180	200	230	250	290		
30						150	160	190	210	230	270		
32						140	150	170	200	210	250	290	
38							130	140	160	180	210	240	280

- Allowable working pressure calculated at -20 to 100°F (-28 to 37°C) using S value of 15,700 psi according to ASME B31.3 Code.
- Safety Factor is 3 to 1, considering ultimate tensile strength of 47,000 psi.
- To determine working pressure of ASME B31.1 Power Piping Code, multiply the ASME 31.3 rating by 0.75.

Table 8. Fractional Seamless Alloy 400 Tubing

Fully annealed seamless Alloy 400 tubing ASTM B165 or equivalent. Tubing to be free from scratches, draw mark, dirt, dust, flat spots, and suitable for bending and flaring. Recommended hardness: 75 HRB or less.

OD in.	Wall Thickness (in.)							
	0.028	0.035	0.049	0.065	0.083	0.095	0.109	0.120
1/8	7,900	10,200						
1/4	3,700	4,800	7,000	9,600				
3/8		3,100	4,400	6,100				
1/2		2,300	3,300	4,400				
3/4			2,200	3,000	4,000	4,600		
1				2,200	2,900	3,400	3,900	4,300

- Allowable working pressure calculated at -20 to 100°F (-28 to 37°C) using S value of 18,700 psi according to ASME B31.3 Code.
- Safety Factor is 3.74 to 1, considering ultimate tensile strength of 70,000 psi.
- To determine working pressure of ASME B31.1 Power Piping Code, multiply the ASME 31.3 rating by 0.93.

Table 9. Fractional Seamless Alloy C276 Tubing

Fully annealed seamless Alloy C276 tubing ASTM B622 or equivalent. Tubing to be free from scratches, draw mark, dirt, dust, flat spots, and suitable for bending and flaring. Recommended hardness: 100 HRB or less.

OD in.	Wall Thickness (in.)					
	0.02	0.028	0.035	0.049	0.065	0.083
1/8	8,200	12,000	15,300			
3/16	5,300	7,700	9,900	14,400		
1/4		5,600	7,200	10,600	14,400	
5/16			5,700	8,200	11,300	
3/8			4,700	6,700	9,200	
1/2			3,400	4,900	6,700	8,800

- Allowable working pressure calculated at ambient temperature using S value of 27,300 psi according to ASME B31.3 Code.
- Safety Factor is 3.66 to 1, considering ultimate tensile strength of 100,000 psi.
- To determine working pressure of ASME B31.1 Power Piping Code, multiply the ASME 31.3 rating by 0.78.

Table 10. Fractional Seamless Alloy 825 Tubing

Fully annealed seamless Alloy 825 tubing ASTM B423 or equivalent. Tubing to be free from scratches, draw mark, dirt, dust, flat spots, and suitable for bending and flaring. Recommended hardness: 95 HRB or less.

OD in.	Wall Thickness (in.)					
	0.02	0.028	0.035	0.049	0.065	0.083
1/8	7,500	11,000	14,000			
3/16	4,800	7,000	9,000	13,000		
1/4		5,100	6,500	9,500	13,000	
5/16			5,100	7,400	10,100	
3/8			4,100	6,000	8,300	
1/2			3,000	4,400	6,000	7,900

- Allowable working pressure calculated at ambient temperature using S value of 23,300 psi according to ASME B31.3 Code.
- Safety Factor is 3.64 to 1, considering ultimate tensile strength of 85,000 psi.
- To determine working pressure of ASME B31.1 Power Piping Code, multiply the ASME 31.3 rating by 0.94.

Table 11. Fractional Seamless Alloy 625 Tubing

Fully annealed seamless Alloy 625 tubing ASTM B444 Grade 1 or equivalent. Tubing to be free from scratches, draw mark, dirt, dust, flat spots, and suitable for bending and flaring.

OD in.	Wall Thickness (in.)					
	0.02	0.028	0.035	0.049	0.065	0.083
1/8	12,500	18,200	23,100	Working Pressure in PSIG		
3/16	8,000	11,600	14,900	21,500		
1/4		8,400	10,800	15,700	21,400	
5/16			8,400	12,200	16,800	
3/8			6,900	10,000	13,700	
1/2			4,200	6,000	8,200	10,700

- Allowable working pressure calculated at ambient temperature using S value of 40,000 psi according to ASME B31.3 Code.
- Safety Factor is 3 to 1, considering ultimate tensile strength of 120,000 psi.

Table 12. Fractional Seamless Super Duplex Tubing

Fully annealed Super Duplex tubing ASTM A789 S32750 or equivalent. Tubing to be free from scratches, draw mark, dirt, dust, flat spots, and suitable for bending and flaring. Recommended hardness: 32 HRC or less.

OD in.	Wall Thickness (in.)		
	0.028	0.035	0.049
1/4	7,700	9,900	
3/8		6,400	9,200
1/2		5,000	7,200

- Allowable working pressure calculated at ambient temperature using S value of 38,700 psi according to ASME B31.3 Code.
- Safety Factor is 3 to 1, considering ultimate tensile strength of 116,000 psi.

Table 13. Fractional Seamless Alloy 20 Tubing

Fully annealed seamless Alloy 20 tubing ASTM B729 or equivalent. Tubing to be free from scratches, draw mark, dirt, dust, flat spots, and suitable for bending and flaring. Recommended hardness: 95 HRB or less.

OD in.	Wall Thickness (in.)					
	0.02	0.028	0.035	0.049	0.065	0.083
1/8	8,400	12,200	15,400			
3/16	5,300	7,700	9,900	14,400		
1/4		5,600	7,200	10,500	14,300	
5/16			5,600	8,200	11,200	
3/8			4,600	6,600	9,100	
1/2			2,800	4,000	5,400	7,200

- Allowable working pressure calculated at ambient temperature using S value of 22,900 psi according to ASME B31.3 Code.
- To determine working pressure of ASME B31.1 Power Piping Code, multiply the ASME 31.3 rating by 0.88.

Table 14.

Temp °F °C	Stainless		C.steel	Copper	825	C276	625	20	400	Super Duplex	
	304	316	A179	B75	B423	B622	B444	B729	B165	A789	
100	38	1	1	1	1	1	1	1	1	1	
200	93	1	1	0.96	0.8	0.92	1	1	0.9	0.88	0.9
300	149	1	1	0.9	0.78	0.87	1	1	0.86	0.79	0.85
400	204	0.94	0.97	0.86	0.5	0.83	1	1	0.83	0.79	0.82
500	260	0.88	0.9	0.82	0.13	0.79	0.98	0.97	0.79	0.79	0.81
600	316	0.82	0.85	0.77		0.76	0.93	0.95	0.77	0.79	0.8
700	371	0.8	0.82	0.73		0.74	0.87	0.93	0.76	0.79	
800	427	0.76	0.8	0.59		0.73	0.84	0.93	0.73	0.76	
900	482	0.73	0.78			0.73	0.81	0.93			
1000	538	0.69	0.77			0.71	0.79	0.93			
1200	649	0.3	0.37				0.35	0.33			

Temperature De-rating Factors

The pressure rating of Dk-Lok port is governed by the connective tubing pressure rating.

To determine allowable working pressure at elevated temperature, multiply working pressure by applicable factor shown in table 14.

Example: SS316 seamless tubing 1/2 in. O.D. x 0.065 in.WT at 700 F. 4700 psig x 0.82 = 3854 psi.

Allowable working pressure of SS316 seamless 1/2 in. O.D. x 0.065 in. WT is 3854 psi at 700 oF.

Dk-Lok Tube Fittings

Dk-Lok Pipe End Pressure Rating

Pressure ratings of Dk-Lok tube port is governed by the connective tubing pressure rating. The allowable working pressure of those fittings with both Dk-Lok port and pipe end port are determined by the lower pressure port.

Table 15. Dk-Lok Pipe Thread Designator.

Legends • DK : Dk-Lok pipe thread designator.
• E : Equivalent.

	DK	Reference Specification	Thread Configuration	E
Tapered Pipe Thread	N	ASME B1.20.1 (NPT) SAE AS71051		-
	R	ISO 7-1 BS EN 10226-1 (BSPT) DIN 2999 (male thread only) JIS B0203 (PT)		RT
Parallel Pipe Thread	G	ISO 228-1 BS 2779 (BSPP) JIS B0202 (PF) DIN 3852 FORM A		RS
	GB	ISO 228-1 BS 2779 (BSPP) JIS B0202 (PF) DIN 3852 FORM B		RP
	GP	ISO 228-1 BS 2779 (BSPP) JIS B0202 (PF) SAE J475 SAE J1926		PR
Parallel Pipe Thread	GG	ISO 228-1 BS 2779 (BSPP) JIS B0202 (PF) EN 837-1 & EN 837-3		RG
	GR	ISO 228-1 BS 2779 (BSPP) JIS B0202 (PF) DIN 3852 FORM Z		RP
	GY	ISO 228-1 BS 2779 (BSPP) JIS B0202 (PF) DIN 3852 FORM Y		RJ
SAE Straight Thread	U	ASME B1.1 ISO R725 SAE J475 SAE J514		ST
	UO	ASME B1.1 ISO R725 SAE J475 SAE J514		OR
	UP	ASME B1.1, ISO R725 SAE J475 SAE J514		ST
	NO	ASME B1.20.1, SAE AS71051 SAE J514		OR

Pipe Thread Sealants

Pipe thread sealant for tapered pipe thread assembly is essential to ensure leak-free thread sealing. Sealant usually contains a lubricant. Thread sealant fills the voids between the threads and prevents thread galling.

Wrap PTFE tape clockwise from first thread. Do not overhang the first thread; the tape may get into the fluid system.

Pressure Equivalents :

1 bar = 100 kPa = 14.503 psi 1 kPa = 0.01 bar = 0.145 psi
1 psi = 0.069 bar = 6.89 kPa 1 kg/cm² = 0.98 bar = 14.22 psi

Table 16. Tapered Pipe Thread Pressure Ratings

Applicable to Dk-Lok thread designator: N and R

ISO/NPT Pipe Size	SS316 and Carbon Steel				Brass			
	Male		Female		Male		Female	
S value	pisg	bar	pisg	bar	pisg	bar	pisg	bar
1/16	14,000	965	6,600	455	7,400	510	3,300	227
1/8	10,000	689	6,400	441	5,000	345	3,200	220
1/4	8,300	572	6,500	448	4,100	282	3,200	220
3/8	8,000	551	5,200	358	4,000	275	2,600	179
1/2	7,800	537	4,800	331	3,900	269	2,400	165
3/4	7,500	517	4,600	317	3,700	255	2,300	158
1	5,300	365	4,400	303	2,600	179	2,200	152
1-1/4	6,200	427	5,000	345	3,100	214	2,500	172
1-1/2	5,100	351	4,500	310	2,500	172	2,200	152
2	4,000	276	3,900	269	2,000	138	1,900	131

Allowable Working Pressure

Dk-Lok ISO Parallel Male Pipe Thread End

Applicable to Dk-Lok thread designator: G, GB, and GP.

SS316 and carbon steel fitting thread ends up to 1 in. are rated to 5900 psi (406 bar)

Dk-Lok SAE Straight Thread End

Applicable to Dk-Lok thread designator: U, UO, and UP.

SS316 and carbon steel fitting thread ends up to 16U (1 5/16-12) are rated to 6000 psi (413 bar)

Dk-Lok Tube Socket Weld End

Applicable to Dk-Lok tube fitting part number: DCSW and DLSW.

SS316 and carbon steel fitting tube socket ends up to 1/2 in. (-8) are rated to 7000 psi (482 bar)

Dk-Lok Pipe Butt Weld End

Applicable to Dk-Lok tube fitting part number: DCW and DLW.

SS316 and carbon steel fitting pipe butt weld ends up to 3/4 in. (-12P) are rated to 6000 psi (413 bar)

- Pressure ratings are based on ASME B31.3 Process Piping Code, at ambient temperature.
- For further information about each size end rating, contact the authorized Dk-Lok distributor in your region.

Table 17. Elastomer seal temperature ratings

Elastomer O-ring	Rating
NBR	-40 to 110°C (-40 to 230°F)
FKM	-28 to 204°C (-18 to 400°F)
FFKM (Kalrez®)	-30 to 275°C (-22 to 527°F)

Care must be taken as fitting with elastomer O-ring seal may have lower temperature rating.

Kalrez® : TM Dupont

Ordering Information

Suffix the material designator to the part number.

Example : DU-8-S

Table 18. Material Designator

Material	Designator
Stainless Steel 316	S
Stainless Steel 316L	L
Brass	B
Carbon Steel	C
Duplex	D
Super Duplex	SD
Aluminum	AL
Alloy 20	L20
Hastelloy C276	HC
Alloy 400	M
Alloy 600	IN
Alloy 625	L625
Alloy 825	L825
Titanium Gr. 2	TI
PTFE	PE

Table 19. Tube O.D. Designator

OD in.	1/16	1/8	3/16	1/4	5/16	3/8	1/2	5/8	3/4	7/8	1	1 1/4	1 1/2	2
Designator	1	2	3	4	5	6	8	10	12	14	16	20	24	32
OD mm	2mm	3mm	4mm	6mm	8mm	10mm	12mm	16mm	20mm	22mm	25mm	28mm	32mm	38mm
Designator	2M	3M	4M	6M	8M	10M	12M	16M	20M	22M	25M	28M	32M	38M

Z series Dk-Lok

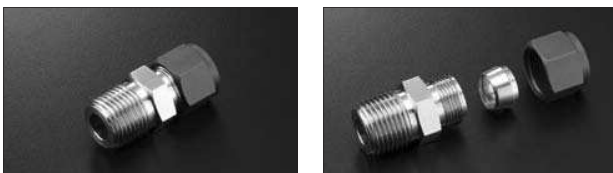

Material

Dk-Lok Z Series single ferrule tube fitting is manufactured in stainless steel 316.

Pressure and Temperature Ratings

Dk-Lok Z Series fittings are identical to Dk-Lok Tube Fittings in pressure and temperature ratings.

Z Series Ferrule

Z series Ferrule	
Part No.	Tube O.D.
DFZ-4	1/4
DFZ-6	3/8
DFZ-8	1/2
DFZ-12	3/4
DFZ-16	1

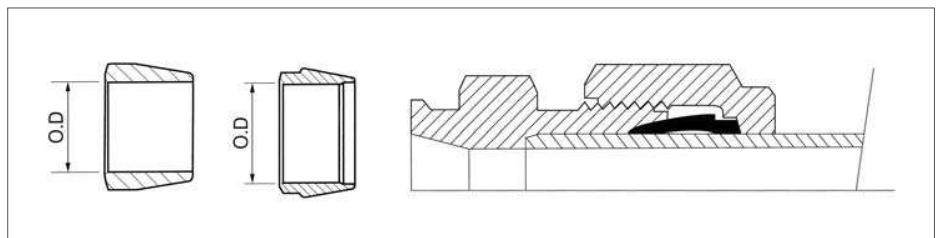

Tee & Cross Fittings

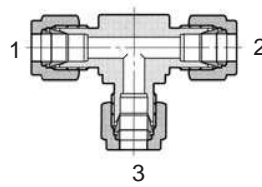

Tee fitting part number is described by first the run (1 and 2) and next the branch (3).

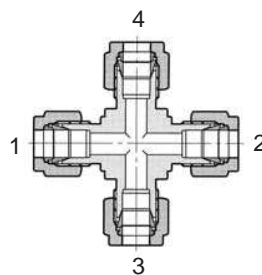

Cross fitting part number is described by first the run (1 and 2) and next the branch (3 and 4).

Table 18. Pipe Thread Size Designator

Nom. Size in.	1/16	1/8	1/4	3/8	1/2	3/4	1	1 1/4	1 1/2	2
Designator	1	2	4	6	8	12	16	20	24	32

Dk-Lok Z Series single ferrule tube fitting is designed and manufactured to the highest quality standards. This fitting includes single ferrule with standard Dk-Lok fitting body and nut. To help identify Dk-Lok Z series from Dk-Lok Tube fitting, nut is black Molybdenum Disulfide (MoS₂) coated.

Dimensions

Dk-Lok Z Series fittings are dimensionally identical to Dk-Lok Tube Fittings.

Ordering Information

To order Z series, insert Z in the standard Dk-Lok tube fitting part number.

Examples : DUZ-8-S, DMCZ8-8N-S, DNZ-4-S

Dk-Lok Tube Fittings

Union DU

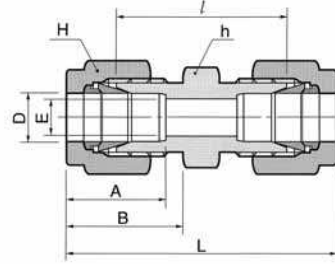
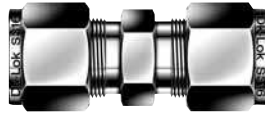

Connects fractional tube

Part No.	Tube O.D.		E Min.	Width across flat				A	B	l	L
	in	mm		h	H	in	mm				
DU-1	1/16	1.59	1.27	5/16	7.93	5/16	7.93	8.63	10.92	17.50	25.15
DU-2	1/8	3.17	2.28	7/16	11.11	7/16	11.11	12.70	15.24	22.35	35.56
DU-3	3/16	4.76	3.04	7/16	11.11	1/2	12.70	13.71	16.00	24.13	37.33
DU-4	1/4	6.35	4.82	1/2	12.70	9/16	14.28	15.24	17.78	26.16	40.89
DU-5	5/16	7.93	6.35	9/16	14.28	5/8	15.87	16.25	18.54	28.19	42.92
DU-6	3/8	9.52	7.11	5/8	15.87	11/16	17.46	16.76	19.30	30.22	44.95
DU-8	1/2	12.70	10.41	13/16	20.64	7/8	22.22	22.86	21.84	30.98	51.30
DU-10	5/8	15.87	12.70	15/16	23.81	1	25.40	24.38	21.84	31.75	52.07
DU-12	3/4	19.05	15.74	1-1/16	26.98	1-1/8	28.58	24.38	21.84	33.27	53.59
DU-14	7/8	22.22	18.28	1-3/16	30.16	1-1/4	31.75	25.90	21.84	35.05	55.37
DU-16	1	25.40	22.35	1-3/8	34.92	1-1/2	38.10	31.24	26.41	40.38	64.77
DU-20	1-1/4	31.75	27.68	1-3/4	44.45	1-7/8	47.63	41.14	38.86	48.00	92.20
DU-24	1-1/2	38.10	34.03	2-1/8	53.97	2-1/4	57.15	50.03	45.21	53.60	107.95
DU-32	2	50.80	45.97	2-3/4	69.85	3	76.20	67.56	62.73	74.70	149.35

Connects metric tube

Part No.	Tube O.D.	E Min.	Width across flat		A	B	l	L
	D		h	H				
DU-2M	2	1.7	12	12	12.9	15.3	22.4	35.6
DU-3M	3	2.4	12	12	12.9	15.3	22.1	35.3
DU-4M	4	2.4	12	12	13.7	16.1	24.1	37.3
DU-6M	6	4.8	14	14	15.3	17.7	26.2	41.0
DU-8M	8	6.4	15	16	16.2	18.6	28.2	43.2
DU-10M	10	7.9	18	19	17.2	19.5	31.0	46.2
DU-12M	12	9.5	22	22	22.8	22.0	31.0	51.2
DU-15M	15	11.9	24	25	24.4	22.0	31.8	52.0
DU-16M	16	12.7	24	25	24.4	22.0	31.8	52.0
DU-18M	18	15.1	27	30	24.4	22.0	33.3	53.5
DU-20M	20	15.9	30	32	26.0	22.0	34.8	55.0
DU-22M	22	18.3	30	32	26.0	22.0	34.8	55.0
DU-25M	25	21.8	35	38	31.3	26.5	40.4	65.0
DU-28M	28	21.8	41	46	36.6	36.6	43.4	85.0
DU-32M	32	28.6	46	50	42.0	41.6	51.3	97.3
DU-38M	38	33.7	55	60	49.4	47.9	58.4	113.6

Union Elbow DL

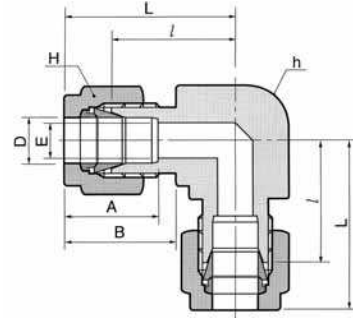

Connects fractional tube

Part No.	Tube O.D.		E Min.	Width across flat				A	B	l	L
	in	mm		h	mm	H	mm				
DL-1	1/16	1.59	1.27	3/8	9.52	5/16	7.93	8.63	10.92	14.00	17.88
DL-2	1/8	3.17	2.28	3/8	9.52	7/16	11.11	12.70	15.24	15.74	22.35
DL-3	3/16	4.76	3.04	1/2	12.70	1/2	12.70	13.71	16.00	17.78	24.38
DL-4	1/4	6.35	4.82	1/2	12.70	9/16	14.28	15.24	17.78	19.55	26.92
DL-5	5/16	7.93	6.35	9/16	14.28	5/8	15.87	16.25	18.54	21.33	28.70
DL-6	3/8	9.52	7.11	5/8	15.87	11/16	17.46	16.76	19.30	23.11	30.48
DL-8	1/2	12.70	10.41	13/16	20.64	7/8	22.22	22.86	21.84	25.90	36.06
DL-10	5/8	15.87	12.70	15/16	23.81	1	25.40	24.38	21.84	28.70	38.80
DL-12	3/4	19.05	15.74	1-1/16	26.98	1-1/8	28.58	24.38	21.84	29.71	39.87
DL-14	7/8	22.22	18.28	1-3/8	34.92	1-1/4	31.75	25.90	21.84	34.54	44.70
DL-16	1	25.40	22.35	1-3/8	34.92	1-1/2	38.10	31.24	26.41	36.83	49.02
DL-20	1-1/4	31.75	27.68	1-11/16	42.86	1-7/8	47.63	41.14	38.86	44.50	66.54
DL-24	1-1/2	38.10	34.03	2	50.80	2-1/4	57.15	50.03	45.21	50.80	77.97
DL-32	2	50.80	45.97	2-3/4	69.85	3	76.20	67.56	62.73	69.80	107.18

Connects metric tube

Part No.	Tube O.D.		E Min.	Width across flat		A	B	l	L
	D	mm		h	H				
DL - 2M	2	2	1.7	9.5	12	12.9	15.3	15.7	22.3
DL - 3M	3	3	2.4	9.5	12	12.9	15.3	15.7	22.3
DL - 4M	4	4	2.4	12.7	12	13.7	16.4	18.8	25.4
DL - 6M	6	6	4.8	12.7	14	15.3	17.7	19.6	27.0
DL - 8M	8	8	6.4	14.3	16	16.2	18.6	21.3	28.8
DL - 10M	10	10	7.9	17.5	19	17.2	19.5	23.9	31.5
DL - 12M	12	12	9.5	20.6	22	22.8	22.0	25.9	36.0
DL - 15M	15	15	11.9	25.4	25	24.4	22.0	28.7	38.8
DL - 16M	16	16	12.7	25.4	25	24.4	22.0	28.7	38.8
DL - 18M	18	18	15.1	27.0	30	24.4	22.0	29.7	39.8
DL - 20M	20	20	15.9	34.92	32	26.0	22.0	32.5	42.6
DL - 22M	22	22	18.3	34.92	32	26.0	22.0	32.5	42.6
DL - 25M	25	25	21.8	34.92	38	31.3	26.5	36.8	49.1
DL - 28M	28	28	21.8	41.0	46	36.6	36.6	43.2	64.0
DL - 32M	32	32	28.6	46.0	50	42.0	41.6	49.3	72.3
DL - 38M	38	38	33.7	55.0	60	49.4	47.9	56.4	84.0

Dk-Lok Tube Fittings

Union Tee DT

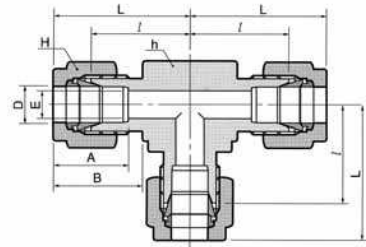

Connects fractional tube

Part No.	Tube O.D. D		E Min.	Width across flat				A	B	l	L
	in	mm		h		H					
				in	mm						
DT-1	1/16	1.59	1.27	3/8	9.52	5/16	7.93	8.63	10.92	14.00	17.88
DT-2	1/8	3.17	2.28	3/8	9.52	7/16	11.11	12.70	15.24	15.74	22.35
DT-3	3/16	4.76	3.04	1/2	12.70	1/2	12.70	13.71	16.00	17.78	24.38
DT-4	1/4	6.35	4.82	1/2	12.70	9/16	14.28	15.24	17.78	19.55	26.92
DT-5	5/16	7.93	6.35	9/16	14.28	5/8	15.87	16.25	18.54	21.33	28.70
DT-6	3/8	9.52	7.11	5/8	15.87	11/16	17.46	16.76	19.30	23.11	30.48
DT-8	1/2	12.70	10.41	13/16	20.64	7/8	22.22	22.86	21.84	25.90	36.06
DT-10	5/8	15.87	12.70	15/16	23.81	1	25.40	24.38	21.84	28.70	38.80
DT-12	3/4	19.05	15.74	1-1/16	26.98	1-1/8	28.58	24.38	21.84	29.71	39.87
DT-14	7/8	22.22	18.28	1-3/8	34.92	1-1/4	31.75	25.90	21.84	34.54	44.70
DT-16	1	25.40	22.35	1-3/8	34.92	1-1/2	38.10	31.24	26.41	36.83	49.02
DT-20	1-1/4	31.75	27.68	1-11/16	42.86	1-7/8	47.63	41.14	38.86	44.50	66.54
DT-24	1-1/2	38.10	34.03	2	50.80	2-1/4	57.15	50.03	45.21	50.80	77.97
DT-32	2	50.80	45.97	2-3/4	69.85	3	76.20	67.56	62.73	69.80	107.18

Connects metric tube

Part No.	Tube O.D. D	E Min.	Width across flat		A	B	l	L
			h	H				
DT - 2M	2	1.7	9.5	12	12.9	15.3	15.7	22.3
DT - 3M	3	2.4	9.5	12	12.9	15.3	15.7	22.3
DT - 4M	4	2.4	12.7	12	13.7	16.1	18.8	25.4
DT - 6M	6	4.8	12.7	14	15.3	17.7	19.6	27.0
DT - 8M	8	6.4	14.3	16	16.2	18.6	21.3	28.8
DT - 10M	10	7.9	17.5	19	17.2	19.5	23.9	31.5
DT - 12M	12	9.5	20.6	22	22.8	22.0	25.9	36.0
DT - 15M	15	11.9	25.4	25	24.4	22.0	28.7	38.8
DT - 16M	16	12.7	25.4	25	24.4	22.0	28.7	38.8
DT - 18M	18	15.1	27.0	30	24.4	22.0	29.7	39.8
DT - 20M	20	15.9	34.92	32	26.0	22.0	32.5	42.6
DT - 22M	22	18.3	34.92	32	26.0	22.0	32.5	42.6
DT - 25M	25	21.8	34.92	38	31.3	26.5	36.8	49.1
DT - 28M	28	21.8	41.0	46	36.6	36.6	43.2	64.0
DT - 32M	32	28.6	46.0	50	42.0	41.6	49.3	72.3
DT - 38M	38	33.7	55.0	60	49.4	47.9	56.4	84.0

Union Cross DX

Note :
Cross may be made out of
bar stock.

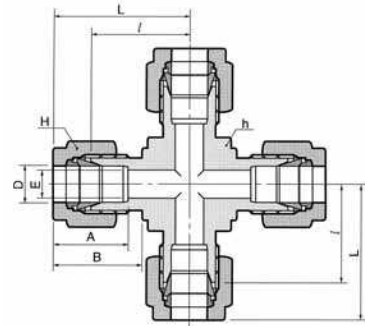
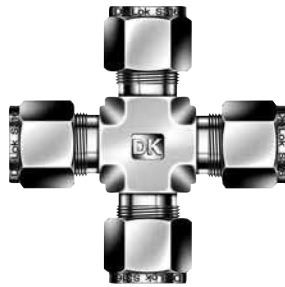

Connects fractional tube

Part No.	Tube O.D.		E Min.	Width across flat				A	B	l	L
	D			h		H					
	in	mm		in	mm	in	mm				
DX-1	1/16	1.59	1.27	3/8	9.52	5/16	7.93	8.63	10.92	14.00	17.88
DX-2	1/8	3.17	2.28	3/8	9.52	7/16	11.11	12.70	15.24	15.74	22.35
DX-3	3/16	4.76	3.04	1/2	12.70	1/2	12.70	13.71	16.00	17.78	24.38
DX-4	1/4	6.35	4.82	1/2	12.70	9/16	14.28	15.24	17.78	19.55	26.92
DX-5	5/16	7.93	6.35	9/16	14.28	5/8	15.87	16.25	18.54	21.33	28.70
DX-6	3/8	9.52	7.11	5/8	15.87	11/16	17.46	16.76	19.30	23.11	30.48
DX-8	1/2	12.70	10.41	13/16	20.64	7/8	22.22	22.86	21.84	25.90	36.06
DX-10	5/8	15.87	12.70	15/16	23.81	1	25.40	24.38	21.84	28.70	38.80
DX-12	3/4	19.05	15.74	1-1/16	26.98	1-1/8	28.58	24.38	21.84	29.71	39.87
DX-14	7/8	22.22	18.28	1-3/8	34.92	1-1/4	31.75	25.90	21.84	34.54	44.70
DX-16	1	25.40	22.35	1-3/8	34.92	1-1/2	38.10	31.24	26.41	36.83	49.02
DX-20	1-1/4	31.75	27.68	1-11/16	42.86	1-7/8	47.63	41.14	38.86	44.50	66.54
DX-24	1-1/2	38.10	34.03	2	50.80	2-1/4	57.15	50.03	45.21	50.80	77.97
DX-32	2	50.80	45.97	2-3/4	69.85	3	76.20	67.56	62.73	69.80	107.18

Connects metric tube

Part No.	Tube O.D.	E Min.	Width across flat		A	B	l	L
	D		h	H				
DX-3M	3	2.4	9.5	12	12.9	15.3	15.7	22.3
DX-4M	4	2.4	12.7	12	13.7	16.1	18.8	25.4
DX-6M	6	4.8	12.7	14	15.3	17.7	19.6	27.0
DX-8M	8	6.4	14.3	16	16.2	18.6	21.3	28.8
DX-10M	10	7.9	17.5	19	17.2	19.5	23.9	31.5
DX-12M	12	9.5	20.6	22	22.8	22.0	25.9	36.0
DX-15M	15	11.9	25.4	25	24.4	22.0	28.7	38.8
DX-16M	16	12.7	25.4	25	24.4	22.0	28.7	38.8
DX-18M	18	15.1	27.0	30	24.4	22.0	29.7	39.8
DX-20M	20	15.9	34.92	32	26.0	22.0	32.5	42.6
DX-22M	22	18.3	34.92	32	26.0	22.0	32.5	42.6
DX-25M	25	21.8	34.92	38	31.3	26.5	36.8	49.1
DX-28M	28	21.8	41.0	46	36.6	36.6	43.2	64.0
DX-32M	32	28.6	46.0	50	42.0	41.6	49.3	72.3
DX-38M	38	33.7	55.0	60	49.4	47.9	56.4	84.0

Dk-Lok Tube Fittings

Bulkhead Union DUB

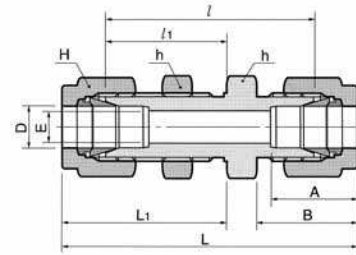

Connects fractional tube

Part No.	Tube O.D. D		E Min.	Width across flat		A	B	l	l ₁	L	L ₁	Panel Hole Drill size	Panel Max Thickness		
	in	mm		h	H										
DUB-1	1/16	1.59	1.27	5/16	7.93	5/16	7.93	8.63	10.92	23.87	13.46	31.50	17.27	5.16	3.05
DUB-2	1/8	3.17	2.28	1/2	12.70	7/16	11.11	12.70	15.24	38.10	24.63	51.30	31.24	8.33	12.70
DUB-3	3/16	4.76	3.04	9/16	14.28	1/2	12.70	13.71	16.00	40.38	25.40	53.59	32.00	9.92	12.70
DUB-4	1/4	6.35	4.82	5/8	15.87	9/16	14.28	15.24	17.78	42.92	26.16	57.65	33.52	11.50	10.16
DUB-5	5/16	7.93	6.35	11/16	17.46	5/8	15.87	16.25	18.54	45.97	28.44	60.70	35.81	13.09	11.17
DUB-6	3/8	9.52	7.11	3/4	19.05	11/16	17.46	16.76	19.30	47.49	29.46	62.23	36.83	14.68	11.17
DUB-8	1/2	12.70	10.41	15/16	23.81	7/8	22.22	22.86	21.84	50.80	31.75	71.12	41.91	19.44	12.70
DUB-10	5/8	15.87	12.70	1-1/16	26.98	1	25.40	24.38	21.84	52.32	32.51	72.64	42.67	22.62	12.70
DUB-12	3/4	19.05	15.74	1-3/16	30.16	1-1/8	28.58	24.38	21.84	58.67	37.33	78.99	47.49	25.79	16.76
DUB-14	7/8	22.22	18.28	1-3/8	34.92	1-1/4	31.75	25.90	21.84	64.26	42.92	84.58	53.08	28.97	19.05
DUB-16	1	25.40	22.35	1-5/8	41.27	1-1/2	38.10	31.24	26.41	71.37	45.21	95.75	57.40	33.73	19.05
DUB-20	1-1/4	31.75	27.68	1-7/8	47.63	1-7/8	47.63	41.14	38.86	78.99	47.75	123.19	69.85	41.67	19.05
DUB-24	1-1/2	38.10	34.03	2-1/4	57.15	2-1/4	57.15	50.03	45.21	84.83	49.27	139.19	76.45	49.61	19.05
DUB-32	2	50.80	45.97	2-3/4	69.85	3	76.20	67.56	62.73	105.66	56.38	180.34	93.72	57.94	19.05

Connects metric tube

Part No.	Tube O.D. D	E Min.	Width across flat		A	B	l	l ₁	L	L ₁	Panel Hole Drill size	Panel Max Thickness
			h	H								
DUB - 3M	3	2.4	14	12	12.9	15.3	38.1	24.6	51.3	31.2	8.3	12.7
DUB - 4M	4	2.4	14	12	13.7	16.1	40.4	25.4	53.6	32.0	9.9	12.7
DUB - 6M	6	4.8	16	14	15.3	17.7	42.9	26.2	57.7	33.6	11.5	10.2
DUB - 8M	8	6.4	18	16	16.2	18.6	46.0	28.6	61.0	36.1	13.1	11.2
DUB - 10M	10	7.9	22	19	17.2	19.5	48.5	29.4	63.7	37.0	16.2	11.2
DUB - 12M	12	9.5	24	22	22.8	22.0	50.8	31.8	71.0	41.9	19.5	12.7
DUB - 15M	15	11.9	27	25	24.4	22.0	52.3	32.5	72.5	42.6	22.8	12.7
DUB - 16M	16	12.7	27	25	24.4	22.0	52.3	32.5	72.5	42.6	22.8	12.7
DUB - 18M	18	15.1	30	30	24.4	22.0	58.7	37.3	78.9	47.4	26.0	16.8
DUB - 20M	20	15.9	35	32	26.0	22.0	64.3	42.9	84.5	53.0	29.0	17.0
DUB - 22M	22	18.3	35	32	26.0	22.0	64.3	42.9	84.5	53.0	29.0	19.0
DUB - 25M	25	21.8	41.3	38	31.3	26.5	71.4	45.2	95.9	57.5	33.7	19.0
DUB - 32M	32	28.6	50	50	42.0	41.6	82.3	49.5	128.3	72.5	42.5	19.0
DUB - 38M	38	33.7	60	60	49.4	47.9	89.4	51.5	144.6	79.1	50.5	19.0

Bulkhead Retainer DBR

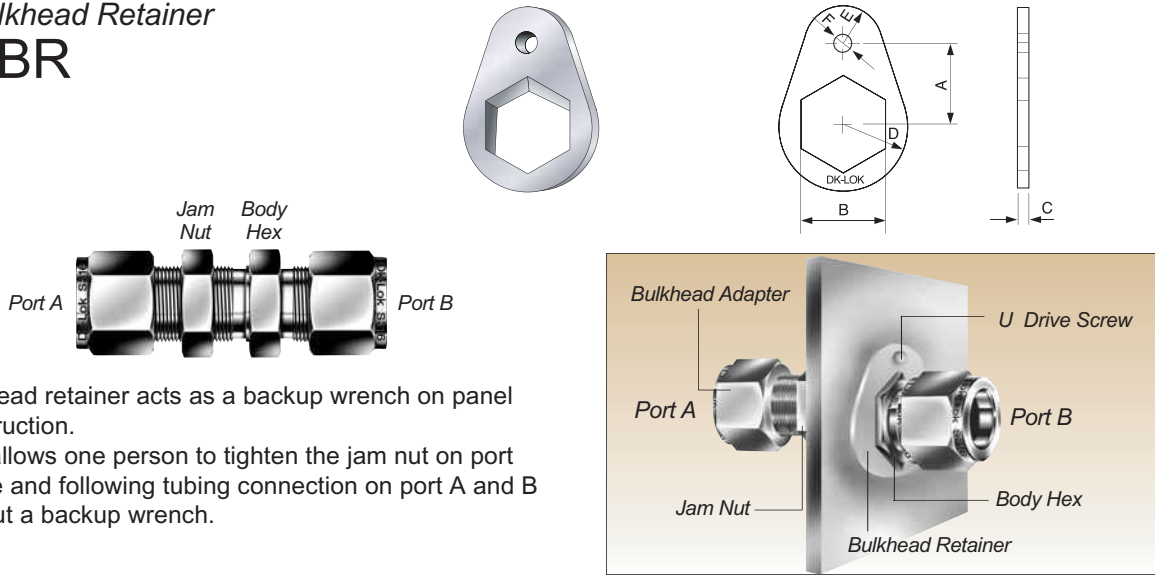

Bulkhead retainer acts as a backup wrench on panel construction. This allows one person to tighten the jam nut on port A side and following tubing connection on port A and B without a backup wrench.

Connects fractional tube

Part No.	Dk-Lok O.D.		A	B	C	D	E	F	"U" Drive Screw	Drill Number	Drill Hole Dia
	in	mm									
DBR-1-S	1/6	-	9.52	7.94	3.18	7.94	3.97	3.97	#6-3/8	31	3.05
DBR-2-S	1/8	-	12.7	12.7	3.18	10.31	5.55	3.97	#6-3/8	31	3.05
DBR-3-S	3/16	3M,4M	14.28	14.28	3.18	11.90	6.35	3.97	#6-3/8	31	3.05
DBR-4-S	1/4	6M	15.87	15.87	3.18	12.7	7.14	3.97	#6-3/8	31	3.05
DBR-5-S	5/16	-	17.46	17.46	3.18	14.28	7.94	3.97	#6-3/8	31	3.05
DBR-8M-S		8M	17.46	18.0	3.18	14.28	7.94	3.97	#6-3/8	31	3.05
DBR-6-S	3/8	-	19.05	19.05	3.18	15.87	8.73	3.97	#6-3/8	31	3.05
DBR-10M-S		10M	23.81	22.0	3.18	19.05	10.31	5.55	#10-1/2	27	3.66
DBR-8-S	1/2	12M	23.81	23.81	3.18	19.05	10.31	5.55	#10-1/2	27	3.66
DBR-10-S	5/8	15M,16M	25.4	26.98	3.18	20.64	10.31	5.55	#10-1/2	27	3.66
DBR-12-S	3/4	18M	26.98	30.16	3.18	23.02	11.90	5.55	#10-1/2	27	3.66
DBR-14-S	7/8	-	28.57	33.33	3.18	26.19	13.49	5.55	#10-1/2	27	3.66
DBR-16-S	1	-	32.54	41.27	3.18	29.37	14.28	5.55	#10-1/2	27	3.66

Bulkhead Elbow Union DBL

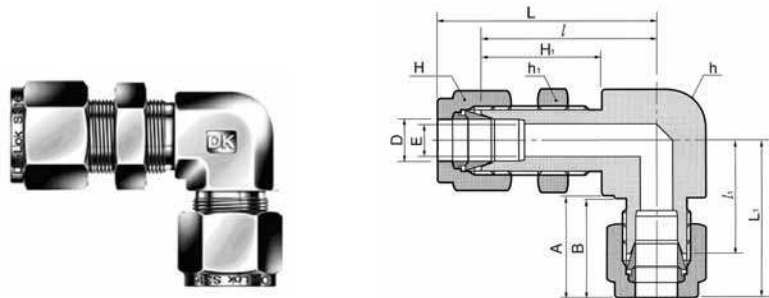

Connects metric tube

Part No.	Tube O.D. (mm)	E Min.	Width across flat			A	B	l	l ₁	L	L ₁	Panel Hole Drill size	Panel Max Thickness
			h	h ₁	H								
DBL-6M	6	4.8	15.8	14.2	14.0	15.3	17.7	36.5	20.6	43.9	30.0	11.5	10.2
DBL-8M	8	6.4	17.4	17.4	16.0	18.6	46.0	40.9	23.2	48.4	30.7	13.1	11.2
DBL-10M	10	7.9	22.0	22.0	19.0	19.5	48.5	44.5	26.9	52.1	34.5	16.2	11.2
DBL-12M	12	9.5	24.0	23.8	22.0	22.0	50.8	46.9	26.9	57.0	37.0	19.5	12.7
DBL-16M	16	13.5	27.0	27.0	25.0	22.0	52.3	53.5	34.1	63.7	44.5	22.8	12.7
DBL-20M	20	15.9	34.9	35.0	32.0	26.0	22.0	68.4	39.0	78.2	48.7	29.0	17.0
DBL-25M	25	21.8	41.0	41.0	38.0	31.3	26.5	74.2	46.1	86.5	58.4	33.7	19.1

Dk-Lok Tube Fittings

Reducing Union DUR

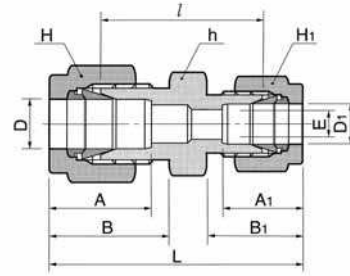
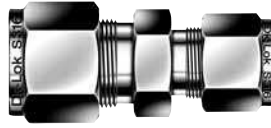

Connects fractional tube

Part No.	Tube O.D.				E Min.	Width across flat						A	A ₁	B	B ₁	l	L
	D		D ₁			h		H		H ₁							
	in	mm	in	mm		in	mm	in	mm	in	mm						
DUR 2-1	1/8	3.18	1/16	1.59	1.27	7/16	11.11	7/16	11.11	5/16	7.93	12.70	8.63	15.24	10.92	20.60	30.91
DUR 3-1	3/16	4.76	1/16	1.59	1.27	7/16	11.11	1/2	12.70	5/16	7.93	13.71	8.63	16.00	10.92	21.84	32.25
DUR 3-2	3/16	4.76	1/8	3.17	2.28	7/16	11.11	1/2	12.70	7/16	11.11	13.71	12.70	16.00	15.24	23.36	36.57
DUR 4-1	1/4	6.35	1/16	1.59	1.27	1/2	12.70	9/16	14.28	5/16	7.93	15.24	8.63	17.78	10.92	23.11	34.29
DUR 4-2	1/4	6.35	1/8	3.17	2.28	1/2	12.70	9/16	14.28	7/16	11.11	15.24	12.70	17.78	15.24	24.63	38.60
DUR 4-3	1/4	6.35	3/16	4.76	3.04	1/2	12.70	9/16	14.28	1/2	12.70	15.24	13.71	17.78	16.00	25.40	39.37
DUR 5-2	5/16	7.93	1/8	3.17	2.28	9/16	14.28	5/8	15.87	7/16	11.11	16.25	12.70	18.54	15.24	25.90	39.87
DUR 5-4	5/16	7.93	1/4	6.35	4.82	9/16	14.28	5/8	15.87	9/16	14.28	16.25	15.24	18.54	17.78	27.43	42.16
DUR 6-1	3/8	9.52	1/16	1.59	1.27	5/8	15.87	11/16	17.46	5/16	7.93	16.76	8.63	19.30	10.92	25.40	36.57
DUR 6-2	3/8	9.52	1/8	3.17	2.28	5/8	15.87	11/16	17.46	7/16	11.11	16.76	12.70	19.30	15.24	26.92	40.89
DUR 6-4	3/8	9.52	1/4	6.35	4.82	5/8	15.87	11/16	17.46	9/16	14.28	16.76	15.24	19.30	17.78	28.44	43.18
DUR 6-5	3/8	9.52	5/16	7.93	6.35	5/8	15.87	11/16	17.46	5/8	15.87	16.76	16.25	19.30	18.54	29.46	44.19
DUR 8-2	1/2	12.70	1/8	3.17	2.28	13/16	20.64	7/8	22.22	7/16	11.11	22.86	12.70	21.84	15.24	28.44	45.21
DUR 8-4	1/2	12.70	1/4	6.35	4.82	13/16	20.64	7/8	22.22	9/16	14.28	22.86	15.24	21.84	17.78	29.46	46.99
DUR 8-6	1/2	12.70	3/8	9.52	7.11	13/16	20.64	7/8	22.22	11/16	17.46	22.86	16.76	21.84	19.30	30.98	48.51
DUR 10-6	5/8	15.87	3/8	9.52	7.11	15/16	23.81	1	25.40	11/16	17.46	24.38	16.76	21.84	19.30	31.75	49.27
DUR 10-8	5/8	15.87	1/2	12.70	10.41	15/16	23.81	1	25.40	7/8	22.22	24.38	22.86	21.84	21.84	31.75	52.07
DUR 12-4	3/4	19.05	1/4	6.35	4.82	1-1/16	26.98	1-1/8	28.57	9/16	14.48	24.38	15.24	21.84	17.78	31.75	49.27
DUR 12-6	3/4	19.05	3/8	9.52	7.11	1-1/16	26.98	1-1/8	28.57	11/16	17.46	24.38	16.76	21.84	19.30	33.27	50.80
DUR 12-8	3/4	19.05	1/2	12.70	10.41	1-1/16	26.98	1-1/8	28.57	7/8	22.22	24.38	22.86	21.84	21.84	33.27	53.59
DUR 12-10	3/4	19.05	5/8	15.87	12.70	1-1/16	26.98	1-1/8	28.57	1	25.40	24.38	24.38	21.84	21.84	33.27	53.59
DUR 16-8	1	25.40	1/2	12.70	10.41	1-3/8	34.92	1-1/2	38.10	7/8	22.22	31.24	22.86	26.41	21.84	40.89	63.24
DUR 16-12	1	25.40	3/4	19.05	15.74	1-3/8	34.92	1-1/2	38.10	1-1/8	28.58	31.24	24.38	26.41	21.84	40.38	62.73

Connects metric tube

Part No.	Tube O.D.		E Min.	Width across flat			A	A ₁	B	B ₁	l	L
	D	D ₁		h	H	H ₁						
	DUR3M-2M	3		2	1.7	12						
DUR6M-2M	6	2	1.7	14	14	12	15.3	12.9	17.7	15.3	24.6	38.6
DUR6M-3M	6	3	2.4	14	14	12	15.3	12.9	17.7	15.3	24.6	38.6
DUR6M-4M	6	4	2.4	14	14	12	15.3	13.7	17.7	16.1	25.4	39.4
DUR8M-6M	8	6	4.8	15	16	14	16.2	15.3	18.6	17.7	27.4	42.3
DUR10M-3M	10	3	2.4	18	19	12	17.2	12.9	19.5	15.3	27.7	41.9
DUR10M-4M	10	4	2.4	18	19	12	17.2	13.7	19.5	16.1	28.7	42.9
DUR10M-6M	10	6	4.8	18	19	14	17.2	15.3	19.5	17.7	29.5	44.5
DUR10M-8M	10	8	6.4	18	19	16	17.2	16.2	19.5	18.6	30.0	45.1
DUR12M-6M	12	6	4.8	22	22	14	22.8	15.3	22.0	17.7	29.5	47.0
DUR12M-8M	12	8	6.4	22	22	16	22.8	16.2	22.0	18.6	30.2	47.8
DUR12M-10M	12	10	7.9	22	22	19	22.8	17.2	22.0	19.5	31.0	48.7
DUR15M-12M	15	12	9.8	24	25	22	24.4	17.2	22.0	19.5	31.8	52.5
DUR16M-10M	16	10	7.9	24	25	19	24.4	17.2	22.0	19.5	31.8	49.5
DUR16M-12M	16	12	9.5	24	25	22	24.4	22.8	22.0	22.0	31.8	52.0
DUR18M-10M	18	10	7.9	27	30	19	24.4	17.2	22.0	19.5	33.0	51.0
DUR18M-12M	18	12	9.5	27	30	22	24.4	22.8	22.0	22.0	33.3	53.5
DUR25M-18M	25	18	15.1	35	38	30	31.3	24.4	26.5	22.0	38.6	61.0
DUR25M-20M	25	20	15.9	35	38	32	31.3	26.0	26.5	22.0	39.9	62.3
DUR30M-18M	30	18	15.1	46	50	30	39.7	24.4	39.3	22.0	43.7	75.4
DUR30M-20M	30	20	15.9	46	50	32	39.7	26.0	39.3	22.0	43.7	75.4
DUR30M-25M	30	25	21.8	46	50	38	39.7	31.3	39.3	26.5	46.2	80.1
DUR32M-18M	32	18	15.1	46	50	30	42.0	24.4	41.6	22.0	44.7	77.8
DUR32M-20M	32	20	15.9	46	50	32	42.0	26.0	41.6	22.0	44.7	77.8
DUR32M-25M	32	25	21.8	46	50	38	42.0	31.3	41.6	26.5	47.0	82.3
DUR38M-20M	38	20	15.9	55	60	32	49.4	26.0	47.9	22.0	49.8	87.5
DUR38M-25M	38	25	21.8	55	60	38	49.4	31.3	47.9	26.5	52.1	92.0
DUR38M-30M	30	30	26.2	55	60	50	49.4	39.7	47.9	39.3	55.4	104.6

Dk-Lok Tube Fittings

Reducing Union Elbow DLR

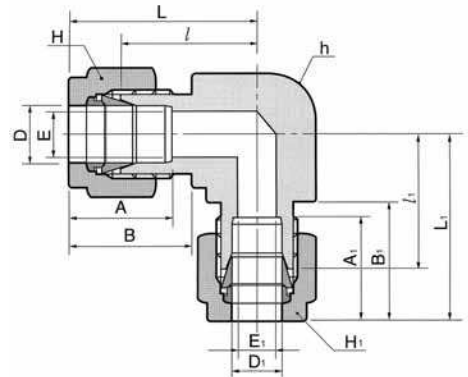

Connects fractional tube

Part No.	Tube O.D.				Width across flat					E	E ₁	A	A ₁	B	B ₁	l	l ₁	L	L ₁	
	D	D ₁	h	H	H ₁															
	in	mm	in	mm	in	mm	in	mm	in	mm										
DLR 2-1	1/8	3.17	1/16	1.59	3/8	9.52	7/6	11.11	5/16	7.93	2.4	1.3	12.7	8.63	15.24	10.93	15.74	14.2	22.35	18.0
DLR 4-2	1/4	6.35	1/8	3.17	1/2	12.7	9/16	14.28	7/6	11.11	4.8	2.4	15.24	12.7	17.78	15.24	19.55	17.9	26.92	24.5
DLR 6-4	3/8	9.52	1/4	6.35	5/8	15.87	11/16	17.46	9/16	14.28	7.1	4.8	16.76	15.24	19.3	17.78	23.1	21.92	30.47	29.29
DLR 8-4	1/2	12.7	1/4	6.35	13/16	20.64	7/8	22.22	9/16	14.28	10.41	4.8	22.86	15.24	21.84	17.78	25.9	24.4	36.06	31.77
DLR 8-6	1/2	12.7	3/8	9.52	13/16	20.64	7/8	22.22	11/16	17.46	10.41	7.1	22.86	16.76	21.84	19.30	25.9	25.9	36.06	33.27

Connects metric tube

Part No.	Tube O.D.				Width across flat					E	E ₁	A	A ₁	B	B ₁	l	l ₁	L	L ₁
	D	D ₁	h	H	H ₁														
	in	mm	in	mm	mm	in	mm	mm	in	mm									
DLR 8M-4	8	1/4	6.35	9/16	14.28	16	9/16	14.28	6.4	4.8	16.2	15.24	18.6	17.78	21.3	20.6	28.7	28.0	

Reducing Union Cross DXR

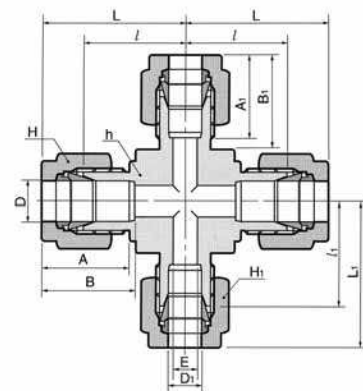
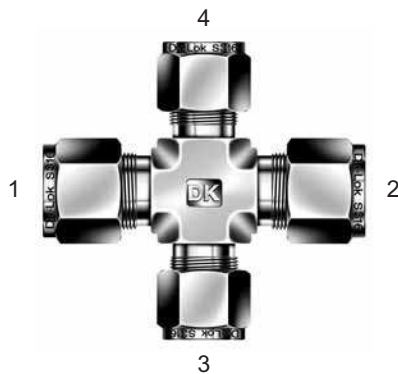

Connects fractional tube

Part No.	Port 1	Port 2	Port 3	Port 4	E Min	Width across flat					A	A ₁	B	B ₁	l	l ₁	L	L ₁	
	D	D ₁	h	H		H ₁													
	in	mm	in	mm	in	mm	in	mm	in	mm									
DXR 12-12-6-6	3/4	19.05	3/8	9.52	7.1	1-1/16	26.98	1-1/8	28.57	11/16	17.46	24.38	16.76	21.84	19.3	29.71	29.71	39.87	37.07

Connects metric tube

Part No.	Port 1	Port 2	Port 3	Port 4	E Min	Width across flat					A	A ₁	B	B ₁	l	l ₁	L	L ₁
	D	D ₁	h	H		H ₁												
	in	mm	in	mm	in	mm	in	mm	in	mm								
DXR 16M-6M-6M-6M	16	6	4.8	25.4	25	14	24.4	15.3	22.0	17.7	28.7	27.2	38.8	34.6				

Reducing Union Tee DTR

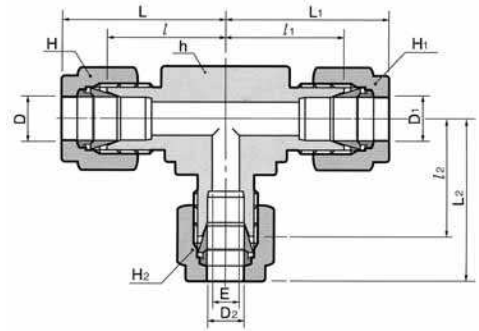

Connects fractional tube

Part No.	Port 1		Port 2		Port 3		E Min	Width across flat						l	l ₁	l ₂	L	L ₁	L ₂		
	D	D ₁	D ₁	D ₂	D ₂	D ₂		h	H	H ₁	H ₂	in	mm							in	mm
DTR 4-4-2	1/4	6.35	1/4	6.35	1/8	3.17	2.4	1/2	12.7	9/16	14.28	9/16	14.28	7/16	11.11	19.55	19.55	17.9	26.91	26.91	24.5
DTR 4-4-6	1/4	6.35	1/4	6.35	3/8	9.52	4.8	5/8	15.87	9/16	14.28	9/16	14.28	11/16	17.46	21.92	21.92	23.1	29.28	29.28	30.46
DTR 4-8-8	1/4	6.35	1/2	12.7	1/2	12.7	4.8	13/16	20.64	9/16	14.28	7/8	22.22	7/8	22.22	24.4	25.9	25.9	31.76	36.06	36.06
DTR 6-4-6	3/8	9.52	1/4	6.35	3/8	9.52	4.8	5/8	15.87	11/16	17.46	9/16	14.28	11/16	17.46	23.1	21.92	23.1	30.46	29.28	30.46
DTR 6-6-4	3/8	9.52	3/8	9.52	1/4	6.35	4.8	5/8	15.87	11/16	17.46	11/16	17.46	9/16	14.28	23.1	23.1	21.92	30.46	30.46	29.28
DTR 6-6-8	3/8	9.52	3/8	9.52	1/2	12.7	7.1	13/16	20.64	11/16	17.46	11/16	17.46	7/8	22.22	25.9	25.9	25.9	33.26	33.26	36.06
DTR 8-4-6	1/2	12.7	1/4	6.35	3/8	9.52	4.8	13/16	20.64	7/8	22.22	9/16	14.28	11/16	17.46	25.9	25.9	25.9	36.06	33.26	33.26
DTR 8-4-8	1/2	12.7	1/4	6.35	1/2	12.7	7.1	13/16	20.64	7/8	22.22	9/16	14.28	7/8	22.22	25.9	24.4	25.9	36.06	31.76	36.06
DTR 8-6-6	1/2	12.7	3/8	9.52	3/8	9.52	7.1	13/16	20.64	7/8	22.22	11/16	17.46	11/16	17.46	25.9	25.9	25.9	36.06	33.26	33.26
DTR 8-8-4	1/2	12.7	1/2	12.7	1/4	6.35	4.8	13/16	20.64	7/8	22.22	7/8	22.22	9/16	14.28	25.9	25.9	24.4	36.06	36.06	31.76
DTR 8-8-6	1/2	12.7	1/2	12.7	3/8	9.52	7.1	13/16	20.64	7/8	22.22	7/8	22.22	11/16	17.46	25.9	25.9	25.9	36.06	36.06	33.26
DTR 10-10-6	5/8	15.87	5/8	15.87	3/8	9.52	7.1	15/16	23.81	1	25.4	1	25.4	11/16	17.46	28.7	28.7	28.7	38.86	38.86	36.06
DTR 12-8-12	3/4	19.05	1/2	12.7	3/4	19.05	10.41	1-1/16	26.98	1-1/8	28.57	7/8	22.22	1-1/8	28.57	29.71	29.71	29.71	39.87	39.87	39.87
DTR 12-12-4	3/4	19.05	3/4	19.05	1/4	6.35	4.8	1-1/16	26.98	1-1/8	28.57	1-1/8	28.57	9/16	14.28	29.71	29.71	28.21	39.87	39.87	35.57
DTR 12-12-6	3/4	19.05	3/4	19.05	3/8	9.52	7.1	1-1/16	26.98	1-1/8	28.57	1-1/8	28.57	11/16	17.46	29.71	29.71	29.71	39.87	39.87	35.57
DTR 12-12-8	3/4	19.05	3/4	19.05	1/2	12.7	10.41	1-1/16	26.98	1-1/8	28.57	1-1/8	28.57	7/8	22.22	29.71	29.71	29.71	39.87	39.87	38.37
DTR 12-12-16	3/4	19.05	3/4	19.05	1	25.4	16.0	1-3/8	34.92	1-1/8	28.57	1-1/8	28.57	1-1/2	38.10	36.83	36.83	35.54	49.02	49.02	45.7
DTR 12-12-20	3/4	19.05	3/4	19.05	1-1/4	31.75	16.0	1-11/16	42.86	1-1/8	28.57	1-1/8	28.57	1-7/8	47.63	39.41	39.41	44.45	49.57	49.57	66.55
DTR 14-14-8	7/8	22.22	7/8	22.22	1/2	12.7	10.41	1-1/4	31.75	1-1/4	31.75	1-1/4	31.75	7/8	22.22	34.54	34.54	34.54	44.7	44.7	44.7
DTR 16-12-12	1	25.4	3/4	19.05	3/4	19.05	16.0	1-3/8	34.92	1-1/2	38.10	1-1/8	28.57	1-1/8	28.57	36.83	35.54	35.54	49.02	45.7	45.7
DTR 16-16-4	1	25.4	1	25.4	1/4	6.35	4.8	1-3/8	34.92	1-1/2	38.10	1-1/2	38.10	9/16	14.28	36.83	36.83	33.04	49.02	49.02	40.4
DTR 16-16-6	1	25.4	1	25.4	3/8	9.52	7.1	1-3/8	34.92	1-1/2	38.10	1-1/2	38.10	11/16	17.46	36.83	36.83	34.54	49.02	49.02	41.9
DTR 16-16-8	1	25.4	1	25.4	1/2	12.7	10.41	1-3/8	34.92	1-1/2	38.10	1-1/2	38.10	7/8	22.22	36.83	36.83	34.54	49.02	49.02	44.7
DTR 16-16-12	1	25.4	1	25.4	3/4	19.05	16.0	1-3/8	34.92	1-1/2	38.10	1-1/2	38.10	1-1/8	28.57	36.83	36.83	35.54	49.02	49.02	45.7
DTR 20-12-12	1 1/4	31.75	3/4	19.05	3/4	19.05	16.0	1-11/16	42.86	1-7/8	47.63	1-1/8	28.57	1-1/8	28.57	44.45	39.41	39.41	66.55	49.57	49.57
DTR 20-20-12	1 1/4	31.75	1 1/4	31.75	3/4	19.05	16.0	1-11/16	42.86	1-7/8	47.63	1-7/8	47.63	1-1/8	28.57	44.45	44.45	39.41	66.55	66.55	49.57
DTR 24-20-20	1 1/2	38.10	1 1/4	31.75	1 1/4	31.75	27.69	2	50.8	2-1/4	57.15	1-7/8	47.63	1-7/8	47.63	50.8	49.62	49.62	77.97	71.72	71.72
DTR 24-24-8	1 1/2	38.10	1 1/2	38.10	1/2	12.7	10.41	2	50.8	2-1/4	57.15	2-1/4	57.15	7/8	22.22	50.8	50.8	44.58	77.97	77.97	54.74
DTR 24-24-12	1 1/2	38.10	1 1/2	38.10	3/4	19.05	16.0	2	50.8	2-1/4	57.15	2-1/4	57.15	1-1/8	28.57	50.8	50.8	44.58	77.97	77.97	54.74
DTR 24-24-16	1 1/2	38.10	1 1/2	38.10	1	25.4	22.3	2	50.8	2-1/4	57.15	2-1/4	57.15	1-1/2	38.10	50.8	50.8	47.75	77.97	77.97	59.94

Dk-Lok Tube Fittings

Reducing Union Tee DTR

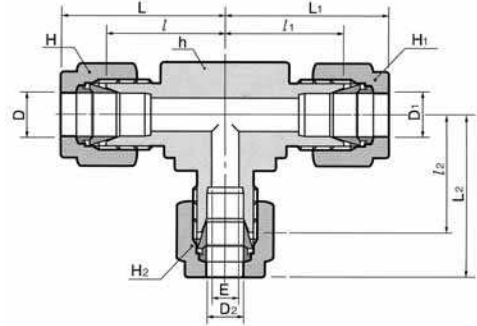

Connects metric tube

Part No.	Port 1	Port 2	Port 3	E Min	Width across flat				A	A ₁	A ₂	B	B ₁	B ₂	l	l ₁	l ₂	L	L ₁	L ₂
	D	D ₁	D ₂		h	H	H ₁	H ₂												
DTR 3M-3M-6M	3	3	6	2.4	12.7	12	12	14	12.9	12.9	15.3	15.3	17.7	18.0	18.0	19.6	24.6	24.6	27.0	
DTR 8M-8M-6M	8	8	6	4.8	15	16	16	14	16.2	16.2	15.3	18.6	18.6	17.7	21.3	21.3	20.5	28.8	28.8	28.0
DTR 10M-10M-6M	10	10	6	4.8	17.4	19	19	14	17.2	17.2	15.3	19.5	19.5	17.7	23.9	23.9	22.4	31.5	31.5	29.8
DTR 10M-10M-12M	10	10	12	7.9	20.6	19	19	22	17.2	17.2	22.8	19.5	19.5	22.0	25.9	25.9	25.9	33.5	33.5	36.0
DTR 12M-6M-10M	12	6	10	4.8	20.6	22	14	19	22.8	15.3	17.2	22.0	17.7	19.5	25.9	24.4	25.9	36.0	31.8	33.5
DTR 12M-6M-12M	12	6	12	4.8	20.6	22	14	22	22.8	15.3	22.8	22.0	17.7	22.0	25.9	24.4	25.9	36.0	31.8	36.0
DTR 12M-10M-10M	12	10	10	7.9	20.6	22	19	19	22.8	17.2	17.2	22.0	19.5	19.5	25.9	25.9	25.9	36.0	33.5	33.5
DTR 12M-12M-10M	12	12	10	7.9	20.6	22	22	19	22.8	22.8	17.2	22.0	22.0	19.5	25.9	25.9	25.9	36.0	36.0	33.5
DTR 12M-12M-6M	12	12	6	4.8	20.6	22	22	14	22.8	22.8	15.3	22.0	22.0	17.7	25.9	25.9	24.4	36.0	36.0	31.8
DTR 15M-15M-12M	15	15	12	9.8	25.4	25	25	22	24.4	24.4	22.8	22.0	22.0	22.0	28.7	28.7	28.7	38.8	38.8	38.8
DTR 16M-16M-12M	16	16	12	9.8	25.4	25	25	22	24.4	24.4	22.8	22.0	22.0	22.0	28.7	28.7	28.7	38.8	38.8	38.8
DTR 18M-18M-12M	18	18	12	9.8	27	30	30	22	24.4	24.4	22.8	22.0	22.0	22.0	29.7	29.7	28.2	39.8	39.8	38.3
DTR 20M-12M-20M	20	12	20	9.8	34.9	32	22	32	26.0	22.8	26.0	22.0	22.0	22.0	32.5	32.5	32.5	42.6	42.6	42.6
DTR 20M-20M-6M	20	20	6	4.8	34.9	32	32	14	26.0	26.0	15.3	22.0	22.0	17.7	32.5	32.5	31.0	42.6	42.6	38.4
DTR 20M-20M-10M	20	20	10	7.9	34.9	32	32	19	26.0	26.0	17.2	22.0	22.0	19.5	32.5	32.5	32.5	42.6	42.6	40.1
DTR 20M-20M-12M	20	20	12	9.8	34.9	32	32	22	26.0	26.0	22.8	22.0	22.0	22.0	32.5	32.5	32.5	42.6	42.6	42.6
DTR 20M-20M-25M	20	20	25	15.9	34.9	32	32	38	26.0	26.0	31.3	22.0	22.0	26.5	34.3	34.3	36.8	44.4	44.4	49.1
DTR 20M-20M-32M	20	20	32	15.9	46	32	32	50	26.0	26.0	42.0	22.0	22.0	41.6	42.5	42.5	49.3	52.6	52.6	72.3
DTR 22M-22M-12M	22	22	12	9.8	34.9	32	32	22	26.0	26.0	22.8	22.0	22.0	22.0	32.5	32.5	32.5	42.6	42.6	42.6
DTR 25M-20M-20M	25	20	20	15.9	34.9	38	32	32	31.3	26.0	26.0	26.5	22.0	22.0	36.8	34.3	34.3	49.1	44.4	44.4
DTR 25M-25M-10M	25	25	10	7.9	34.9	38	38	19	31.3	31.3	17.2	26.5	26.5	19.5	36.8	36.8	34.3	49.1	49.1	38.9
DTR 25M-25M-12M	25	25	12	9.8	34.9	38	38	22	31.3	31.3	22.8	26.5	26.5	22.0	36.8	36.8	34.3	49.1	49.1	44.4
DTR 25M-25M-20M	25	25	20	15.9	34.9	38	38	32	31.3	31.3	26.0	26.5	26.5	22.0	36.8	36.8	34.3	49.1	49.1	44.4
DTR 32M-32M-20M	32	32	20	15.9	46	38	38	32	42.0	42.0	26.0	41.6	41.6	22.0	49.3	49.3	42.5	72.3	72.3	52.6
DTR 38M-32M-32M	38	32	32	28.6	55	60	38	38	49.4	42.0	42.0	47.9	41.6	41.6	56.4	54.7	54.7	84.0	77.7	77.7
DTR 38M-38M-20M	38	38	20	15.9	55	60	60	32	49.4	49.4	26.0	47.9	47.9	22.0	56.4	56.4	47.9	84.0	84.0	58.0
DTR 38M-38M-25M	38	38	25	21.8	55	60	60	38	49.4	49.4	31.3	47.9	47.9	26.5	56.4	56.4	50.4	84.0	84.0	62.7

Dk-Lok Tube Fittings

Male Connector DMC-N

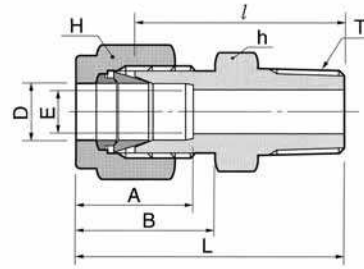
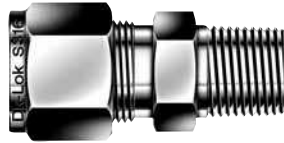

Connects fractional tube to female NPT thread

Part No.	Tube O.D.		T NPT	E Min.	Width across flat				A	B	l	L
	in	mm			h	H	in	mm				
DMC1-1N	1/16	1.59	1/16	1.27	5/16	7.93	5/16	7.93	8.63	10.92	20.00	23.83
DMC1-2N	1/16	1.59	1/8	1.27	7/16	11.11	5/16	7.93	8.63	10.92	22.35	26.23
DMC1-4N	1/16	1.59	1/4	1.27	9/16	14.28	5/16	7.93	8.63	10.92	27.17	30.98
DMC2-1N	1/8	3.17	1/16	2.28	7/16	11.11	7/16	11.11	12.70	15.24	23.11	29.71
DMC2-2N	1/8	3.17	1/8	2.28	7/16	11.11	7/16	11.11	12.70	15.24	23.87	30.48
DMC2-4N	1/8	3.17	1/4	2.28	9/16	14.28	7/16	11.11	12.70	15.24	28.95	35.56
DMC2-6N	1/8	3.17	3/8	2.28	11/16	17.46	7/16	11.11	12.70	15.24	29.21	35.81
DMC2-8N	1/8	3.17	1/2	2.28	7/8	22.22	7/16	11.11	12.70	15.24	35.56	42.16
DMC3-2N	3/16	4.76	1/8	3.04	7/16	11.11	1/2	12.70	13.71	16.00	24.63	31.24
DMC3-4N	3/16	4.76	1/4	3.04	9/16	14.28	1/2	12.70	13.71	16.00	29.71	36.32
DMC4-1N	1/4	6.35	1/16	4.82	1/2	12.70	9/16	14.28	15.24	17.78	25.40	32.76
DMC4-2N	1/4	6.35	1/8	4.82	1/2	12.70	9/16	14.28	15.24	17.78	25.40	32.76
DMC4-4N	1/4	6.35	1/4	4.82	9/16	14.28	9/16	14.28	15.24	17.78	30.48	37.84
DMC4-6N	1/4	6.35	3/8	4.82	11/16	17.46	9/16	14.28	15.24	17.78	30.98	38.35
DMC4-8N	1/4	6.35	1/2	4.82	7/8	22.22	9/16	14.28	15.24	17.78	37.33	44.70
DMC4-12N	1/4	6.35	3/4	4.82	1-1/16	26.98	9/16	14.28	15.24	17.78	38.86	46.22
DMC5-2N	5/16	7.93	1/8	4.82	9/16	14.28	5/8	15.87	16.25	18.54	26.67	34.03
DMC5-4N	5/16	7.93	1/4	6.35	9/16	14.28	5/8	15.87	16.25	18.54	31.24	38.60
DMC5-6N	5/16	7.93	3/8	6.35	11/16	17.46	5/8	15.87	16.25	18.54	31.75	39.11
DMC5-8N	5/16	7.93	1/2	6.35	7/8	22.22	5/8	15.87	16.25	18.54	38.11	45.60
DMC6-2N	3/8	9.52	1/8	4.82	5/8	15.87	11/16	17.46	16.76	19.30	27.94	35.30
DMC6-4N	3/8	9.52	1/4	7.11	5/8	15.87	11/16	17.46	16.76	19.30	32.51	39.87
DMC6-6N	3/8	9.52	3/8	7.11	11/16	17.46	11/16	17.46	16.76	19.30	32.51	39.87
DMC6-8N	3/8	9.52	1/2	7.11	7/8	22.22	11/16	17.46	16.76	19.30	38.86	46.22
DMC6-12N	3/8	9.52	3/4	7.11	1-1/16	26.98	11/16	17.46	16.76	19.30	40.38	47.75
DMC6-16N	3/8	9.52	1	7.11	1-3/8	34.92	11/16	17.46	16.76	19.30	47.0	54.37
DMC8-2N	1/2	12.70	1/8	4.82	13/16	20.64	7/8	22.22	22.86	21.84	28.70	38.86
DMC8-4N	1/2	12.70	1/4	7.11	13/16	20.64	7/8	22.22	22.86	21.84	33.27	43.43
DMC8-6N	1/2	12.70	3/8	9.65	13/16	20.64	7/8	22.22	22.86	21.84	33.27	43.43
DMC8-8N	1/2	12.70	1/2	10.41	7/8	22.22	7/8	22.22	22.86	21.84	38.86	49.02
DMC8-12N	1/2	12.70	3/4	10.41	1-1/16	26.98	7/8	22.22	22.86	21.84	40.38	50.54
DMC8-16N	1/2	12.70	1	10.41	1-3/8	34.92	7/8	22.22	22.86	21.84	46.99	57.15
DMC10-4N	5/8	15.87	1/4	6.35	15/16	23.81	1	25.40	24.38	21.84	33.80	43.96
DMC10-6N	5/8	15.87	3/8	9.65	15/16	23.81	1	25.40	24.38	21.84	34.03	44.19
DMC10-8N	5/8	15.87	1/2	11.93	15/16	23.81	1	25.40	24.38	21.84	38.86	49.02
DMC10-12N	5/8	15.87	3/4	12.70	1-1/16	26.98	1	25.40	24.38	21.84	40.38	50.54
DMC12-6N	3/4	19.05	3/8	9.65	1-1/16	26.98	1-1/8	28.58	24.38	21.84	34.03	44.19
DMC12-8N	3/4	19.05	1/2	11.93	1-1/16	26.98	1-1/8	28.58	24.38	21.84	40.38	50.54
DMC12-12N	3/4	19.05	3/4	15.74	1-1/16	26.98	1-1/8	28.58	24.38	21.84	40.38	50.54
DMC12-16N	3/4	19.05	1	15.74	1-3/8	34.92	1-1/8	28.58	24.38	21.84	46.99	57.15
DMC14-8N	7/8	22.22	1/2	11.9	1-3/16	30.16	1-1/4	31.75	25.90	21.84	40.38	50.54
DMC14-12N	7/8	22.22	3/4	15.74	1-3/16	30.16	1-1/4	31.75	25.90	21.84	40.38	50.54
DMC14-16N	7/8	22.22	1	18.28	1-3/8	34.92	1-1/4	31.75	25.90	21.84	46.99	57.15
DMC16-6N	1	25.40	3/8	9.65	1-3/8	34.92	1-1/2	38.10	31.24	26.41	40.30	52.49
DMC16-8N	1	25.40	1/2	11.93	1-3/8	34.92	1-1/2	38.10	31.24	26.41	45.21	57.40
DMC16-12N	1	25.40	3/4	15.74	1-3/8	34.92	1-1/2	38.10	31.24	26.41	45.21	57.40
DMC16-16N	1	25.40	1	22.35	1-3/8	34.62	1-1/2	38.10	31.24	26.41	50.03	62.23
DMC20-16N	1-1/4	31.75	1	22.35	1-3/4	44.45	1-7/8	47.63	41.14	38.86	55.11	77.21
DMC20-20N	1-1/4	31.75	1-1/4	27.68	1-3/4	44.45	1-7/8	47.63	41.14	38.86	55.11	77.21
DMC20-24N	1-1/4	31.75	1-1/2	27.68	1-3/4	44.45	1-7/8	47.63	41.14	38.86	60.54	82.64
DMC24-16N	1-1/2	38.10	1	22.30	2-1/8	53.98	2-1/4	57.15	50.03	45.21	59.42	86.60
DMC24-20N	1-1/2	38.10	1-1/4	27.68	2-1/8	53.98	2-1/4	57.15	50.03	45.21	59.42	86.60
DMC24-24N	1-1/2	38.10	1-1/2	34.03	2-1/8	53.98	2-1/4	57.15	50.03	45.21	61.72	88.90
DMC24-32N	1-1/2	38.10	2	34.03	2-3/4	69.85	2-1/4	57.15	50.03	45.21	62.42	99.75
DMC32-8N	2	50.80	1/2	11.93	2-3/4	69.85	3	76.20	67.56	62.73	68.40	105.73
DMC32-20N	2	50.80	1-1/4	45.97	2-3/4	69.85	3	76.20	67.56	62.73	71.40	108.73
DMC32-24N	2	50.80	1-1/2	45.97	2-3/4	69.85	3	76.20	67.56	62.73	75.50	112.83
DMC32-32N	2	50.80	2	45.97	2-3/4	69.85	3	76.20	67.56	62.73	76.20	113.53

Dk-Lok Tube Fittings

Male Connector DMC-N

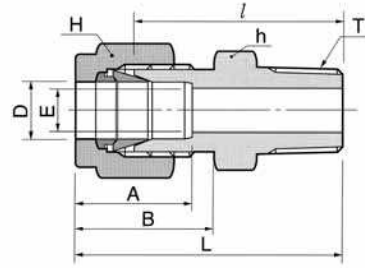
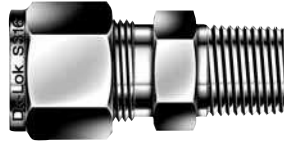

Connects metric tube to female NPT thread

Part No.	Tube O.D. D	T NPT	E Min.	Width across flat		A	B	l	L
				h	H				
DMC2M-2N	2	1/8	1.7	12	12	12.9	15.3	23.9	30.5
DMC3M-2N	3	1/8	2.4	12	12	12.9	15.3	23.1	29.7
DMC3M-4N	3	1/4	2.4	14	12	12.9	15.3	29.0	35.6
DMC4M-2N	4	1/8	2.4	12	12	13.7	16.1	24.6	31.2
DMC4M-4N	4	1/4	2.4	14	12	13.7	16.1	29.7	36.3
DMC6M-2N	6	1/8	4.8	14	14	15.3	17.7	25.4	32.8
DMC6M-4N	6	1/4	4.8	14	14	15.3	17.7	30.2	37.6
DMC6M-6N	6	3/8	4.8	18	14	15.3	17.7	31.0	38.4
DMC6M-8N	6	1/2	4.8	22	14	15.3	17.7	37.3	44.0
DMC8M-2N	8	1/8	4.8	15	16	16.2	18.6	26.7	34.2
DMC8M-4N	8	1/4	6.4	15	16	16.2	18.6	31.2	38.7
DMC8M-6N	8	3/8	6.4	18	16	16.2	18.6	31.8	39.2
DMC8M-8N	8	1/2	6.4	22	16	16.2	18.6	37.3	44.8
DMC10M-2N	10	1/8	4.8	18	19	17.2	19.5	28.7	36.3
DMC10M-4N	10	1/4	7.1	18	19	17.2	19.5	33.3	40.9
DMC10M-6N	10	3/8	7.9	18	19	17.2	19.5	33.3	40.9
DMC10M-8N	10	1/2	7.9	22	19	17.2	19.5	38.1	45.7
DMC10M-12N	10	3/4	7.9	27	19	17.2	19.5	38.9	46.5
DMC12M-2N	12	1/8	4.8	22	22	22.8	22.0	28.7	38.8
DMC12M-4N	12	1/4	7.1	22	22	22.8	22.0	33.3	43.4
DMC12M-6N	12	3/8	9.5	22	22	22.8	22.0	33.3	43.4
DMC12M-8N	12	1/2	9.5	22	22	22.8	22.0	38.1	48.2
DMC12M-12N	12	3/4	9.5	27	22	22.8	22.0	38.9	49.0
DMC14M-4N	14	1/4	6.4	24	25	24.4	22.0	34.0	44.1
DMC14M-6N	14	3/8	9.5	24	25	24.4	22.0	34.0	44.1
DMC14M-8N	14	1/2	11.1	24	25	24.4	22.0	34.0	44.1
DMC15M-8N	15	1/2	11.9	24	25	24.4	22.0	38.9	49.0
DMC16M-4N	16	1/4	7.1	24	25	24.4	22.0	34.0	44.1
DMC16M-6N	16	3/8	9.5	24	25	24.4	22.0	34.0	44.1
DMC16M-8N	16	1/2	11.9	24	25	24.4	22.0	38.9	49.0
DMC16M-12N	16	3/4	12.7	27	25	24.4	22.0	38.9	49.0
DMC18M-8N	18	1/2	11.9	27	30	24.4	22.0	40.4	50.5
DMC18M-12N	18	3/4	15.1	27	30	24.4	22.0	40.4	50.5
DMC20M-8N	20	1/2	11.9	30	32	26.0	22.0	42.2	52.3
DMC20M-12N	20	3/4	15.9	30	32	26.0	22.0	42.2	52.3
DMC22M-12N	22	3/4	15.9	30	32	26.0	22.0	42.2	52.3
DMC22M-16N	22	1	18.3	35	32	26.0	22.0	47.8	57.9
DMC25M-8N	25	1/2	11.9	35	38	31.3	26.5	45.2	57.5
DMC25M-12N	25	3/4	15.9	35	38	31.3	26.5	45.2	57.5
DMC25M-16N	25	1	21.8	35	38	31.3	26.5	50.0	62.3
DMC28M-16N	28	1	21.8	41	46	36.6	36.6	51.6	72.4
DMC28M-20N	28	1-1/4	21.8	46	46	36.6	36.6	52.3	73.1
DMC30M-20N	30	1-1/4	26.2	46	50	39.6	39.2	55.6	77.2
DMC32M-20N	32	1-1/4	28.6	46	50	42.0	41.6	56.6	79.6
DMC38M-24N	38	1-1/2	33.7	55	60	49.4	47.9	64.0	91.6

Male Connector DMC-R

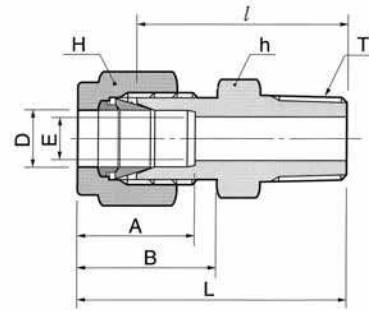
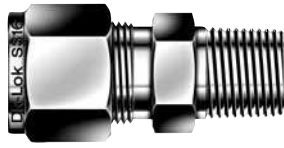

Connects fractional tube to female ISO tapered thread

Part No.	Tube O.D.		T PT	E Min.	Width across flat				A	B	l	L
	in	mm			h	mm	in	mm				
DMC2-2R	1/8	3.17	1/8	2.28	7/16	11.11	7/16	11.11	12.70	15.24	23.87	30.48
DMC2-4R	1/8	3.17	1/4	2.28	9/16	14.28	7/16	11.11	12.70	15.24	28.95	35.56
DMC4-2R	1/4	6.35	1/8	4.82	1/2	12.70	9/16	14.28	15.24	17.78	25.40	32.76
DMC4-4R	1/4	6.35	1/4	4.82	9/16	14.28	9/16	14.28	15.24	17.78	30.48	37.84
DMC4-6R	1/4	6.35	3/8	4.82	11/16	17.46	9/16	14.28	15.24	17.78	30.98	38.35
DMC4-8R	1/4	6.35	1/2	4.82	7/8	22.22	9/16	14.28	15.24	17.78	37.33	44.70
DMC5-2R	5/16	7.93	1/8	4.82	9/16	14.28	5/8	15.87	16.25	18.54	26.67	34.03
DMC5-4R	5/16	7.93	1/4	6.35	9/16	14.28	5/8	15.87	16.25	18.54	31.24	38.60
DMC5-16R	5/16	7.93	1	6.35	1-3/8	34.92	5/8	15.87	16.25	18.54	46.2	50.0
DMC6-2R	3/8	9.52	1/8	4.82	5/8	15.87	11/16	17.46	16.76	19.30	27.94	35.30
DMC6-4R	3/8	9.52	1/4	7.11	5/8	15.87	11/16	17.46	16.76	19.30	32.51	39.87
DMC6-6R	3/8	9.52	3/8	7.11	11/16	17.46	11/16	17.46	16.76	19.30	32.51	39.87
DMC6-8R	3/8	9.52	1/2	7.11	7/8	22.22	11/16	17.46	16.76	19.30	38.86	46.22
DMC6-12R	3/8	9.52	3/4	7.11	1-1/16	26.98	11/16	17.46	16.76	19.30	40.38	47.75
DMC8-2R	1/2	12.70	1/8	4.82	13/16	20.64	7/8	22.22	22.86	21.84	28.70	38.86
DMC8-4R	1/2	12.70	1/4	7.11	13/16	20.64	7/8	22.22	22.86	21.84	33.27	43.43
DMC8-6R	1/2	12.70	3/8	9.65	13/16	20.64	7/8	22.22	22.86	21.84	33.27	43.43
DMC8-8R	1/2	12.70	1/2	10.41	7/8	22.22	7/8	22.22	22.86	21.84	38.86	49.02
DMC8-12R	1/2	12.70	3/4	10.41	1-1/16	26.98	7/8	22.22	22.86	21.84	40.38	50.54
DMC8-16R	1/2	12.70	1	10.41	1-3/8	34.92	7/8	22.22	22.86	21.84	46.99	57.15
DMC10-6R	5/8	15.87	3/8	9.65	15/16	23.81	1	25.40	24.38	21.84	34.03	44.19
DMC10-8R	5/8	15.87	1/2	11.93	15/16	23.81	1	25.40	24.38	21.84	38.86	49.02
DMC10-12R	5/8	15.87	3/4	12.70	1-1/16	26.98	1	25.40	24.38	21.84	40.38	50.54
DMC12-8R	3/4	19.05	1/2	11.93	1-1/16	26.98	1-1/8	28.58	24.38	21.84	40.38	50.54
DMC12-12R	3/4	19.05	3/4	15.74	1-1/16	26.98	1-1/8	28.58	24.38	21.84	40.38	50.54
DMC12-16R	3/4	19.05	1	15.74	1-3/8	34.92	1-1/8	28.58	24.38	21.84	46.99	57.15
DMC16-12R	1	25.40	3/4	15.74	1-3/8	34.92	1-1/2	38.10	31.24	26.41	45.21	57.40
DMC16-16R	1	25.40	1	22.35	1-3/8	34.62	1-1/2	38.10	31.24	26.41	50.03	62.23
DMC20-12R	1-1/4	31.75	3/4	15.74	1-3/4	44.45	1-7/8	47.63	41.14	38.86	50.0	72.10
DMC20-16R	1-1/4	31.75	1	22.35	1-3/4	44.45	1-7/8	47.63	41.14	38.86	55.11	77.21
DMC20-20R	1-1/4	31.75	1-1/4	27.68	1-3/4	44.45	1-7/8	47.63	41.14	38.86	55.11	77.21
DMC32-32R	2	50.80	2	45.97	2-3/4	69.85	3	76.20	67.56	62.73	76.20	113.53

Thermocouple Connector DMCT

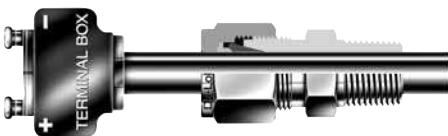

Most Dk-Lok male connectors can be bored-through thermocouple fittings except those fittings with small male thread like 1/8 in.

To order, insert T in DMC male connector part number. Example: DMCT8-8N-S

Dk-Lok bored-through fittings have no shoulder or sizing angle inside the body. This allows thermocouples or dip tubes to pass beyond the fitting male thread.

Assembly Instructions

1. Position the length of thermocouple to pass through fitting male thread and hold it to prevent shifting during assembly.
2. Wrench tightens the nut 1 1/4 turns from finger tight position, keeping the body steady with backup wrench.
 - Tighten the nut 3/4 turn for 1/8, and 3/16; 3, and 4mm tube fittings.

Dk-Lok Tube Fittings

Male Connector DMC-R

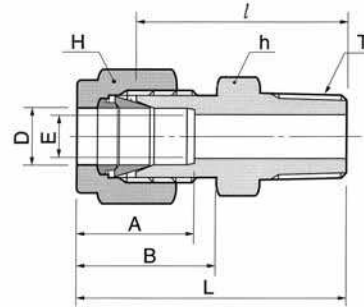
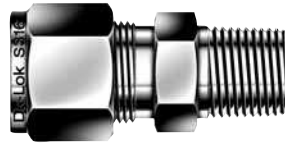

Connects metric tube to female ISO tapered thread

Part No.	Tube O.D. D	T PT	E Min.	Width across flat		A	B	l	L
				h	H				
DMC2M-2R	2	1/8	1.7	12	12	12.9	15.3	23.9	30.5
DMC3M-2R	3	1/8	2.4	12	12	12.9	15.3	23.1	29.7
DMC3M-4R	3	1/4	2.4	14	12	12.9	15.3	29.0	35.6
DMC4M-2R	4	1/8	2.4	12	12	13.7	16.1	24.6	31.2
DMC4M-4R	4	1/4	2.4	14	12	13.7	16.1	29.7	36.3
DMC6M-2R	6	1/8	4.8	14	14	15.3	17.7	25.4	32.8
DMC6M-4R	6	1/4	4.8	14	14	15.3	17.7	30.2	37.6
DMC6M-6R	6	3/8	4.8	18	14	15.3	17.7	31.0	38.4
DMC6M-8R	6	1/2	4.8	22	14	15.3	17.7	37.3	44.0
DMC8M-2R	8	1/8	4.8	15	16	16.2	18.6	26.7	34.2
DMC8M-4R	8	1/4	6.4	15	16	16.2	18.6	31.2	38.7
DMC8M-6R	8	3/8	6.4	18	16	16.2	18.6	31.8	39.2
DMC8M-8R	8	1/2	6.4	22	16	16.2	18.6	37.3	44.8
DMC10M-2R	10	1/8	4.8	18	19	17.2	19.5	28.7	36.3
DMC10M-4R	10	1/4	7.1	18	19	17.2	19.5	33.3	40.9
DMC10M-6R	10	3/8	7.9	18	19	17.2	19.5	33.3	40.9
DMC10M-8R	10	1/2	7.9	22	19	17.2	19.5	38.1	45.7
DMC10M-12R	10	3/4	7.9	27	19	17.2	19.5	38.9	46.5
DMC12M-4R	12	1/4	7.1	22	22	22.8	22.0	33.3	43.4
DMC12M-6R	12	3/8	9.5	22	22	22.8	22.0	33.3	43.4
DMC12M-8R	12	1/2	9.5	22	22	22.8	22.0	38.1	48.2
DMC12M-12R	12	3/4	9.5	27	22	22.8	22.0	38.9	49.0
DMC14M-6R	14	3/8	9.5	24	25	24.4	22.0	34.0	44.1
DMC14M-8R	14	1/2	11.1	24	25	24.4	22.0	34.0	44.1
DMC15M-6R	15	3/8	9.5	24	25	24.4	22.0	34.0	44.1
DMC15M-8R	15	1/2	11.9	24	25	24.4	22.0	38.9	49.0
DMC16M-4R	16	1/4	7.1	24	25	24.4	22.0	34.0	44.1
DMC16M-6R	16	3/8	9.5	24	25	24.4	22.0	34.0	44.1
DMC16M-8R	16	1/2	11.9	24	25	24.4	22.0	38.9	49.0
DMC16M-12R	16	3/4	12.7	27	25	24.4	22.0	38.9	49.0
DMC18M-8R	18	1/2	11.9	27	30	24.4	22.0	40.4	50.5
DMC18M-12R	18	3/4	15.1	27	30	24.4	22.0	40.4	50.5
DMC20M-8R	20	1/2	11.9	30	32	26.0	22.0	42.2	52.3
DMC20M-12R	20	3/4	15.9	30	32	26.0	22.0	42.2	52.3
DMC22M-8R	22	1/2	11.9	30	32	26.0	22.0	42.2	52.3
DMC22M-12R	22	3/4	15.9	30	32	26.0	22.0	42.2	52.3
DMC22M-16R	22	1	18.3	35	32	26.0	22.0	47.8	57.9
DMC25M-8R	25	1/2	11.9	35	38	31.3	26.5	45.2	57.5
DMC25M-12R	25	3/4	15.9	35	38	31.3	26.5	45.2	57.5
DMC25M-16R	25	1	21.8	35	38	31.3	26.5	50.0	62.3
DMC28M-16R	28	1	21.8	41	46	36.6	36.6	51.6	72.4
DMC28M-20R	28	1-1/4	21.8	46	46	36.6	36.6	52.3	73.1
DMC30M-20R	30	1-1/4	26.2	46	50	39.6	39.2	55.6	77.2
DMC32M-20R	32	1-1/4	28.6	46	50	42.0	41.6	56.6	79.6
DMC38M-24R	38	1-1/2	33.7	55	60	49.4	47.9	64.0	91.6

Male Connector for Bonded Gasket Seal DMC-G

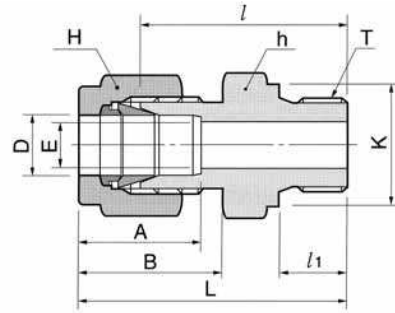
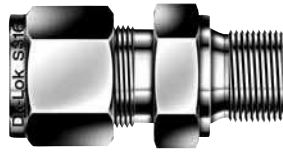

Connects fractional tube to female ISO parallel thread

Part No.	Tube O.D.		T PF	E Min.	Width across flat				A	B	l	l ₁	L	K
	in	mm			in	mm	in	mm						
DMC2-2G	1/8	3.17	1/8	2.28	9/16	14.28	7/16	11.11	12.70	15.24	23.37	7.11	29.97	13.80
DMC2-4G	1/8	3.17	1/4	2.28	3/4	19.05	7/16	11.11	12.70	15.24	28.70	11.18	35.31	18.00
DMC2-6G	1/8	3.17	3/8	2.28	7/8	22.22	7/16	11.11	12.70	15.24	29.72	11.18	36.21	21.80
DMC4-2G	1/4	6.35	1/8	2.28	9/16	14.28	9/16	14.28	15.24	17.78	24.89	7.11	32.26	13.80
DMC4-4G	1/4	6.35	1/4	4.8	3/4	19.05	9/16	14.28	15.24	17.78	30.23	11.18	37.59	18.00
DMC4-6G	1/4	6.35	3/8	4.8	7/8	22.22	9/16	14.28	15.24	17.78	31.50	11.18	38.86	21.80
DMC4-8G	1/4	6.35	1/2	4.8	1-1/16	26.98	9/16	14.28	15.24	17.78	37.34	14.22	44.70	26.00
DMC6-2G	3/8	9.52	1/8	4.8	5/8	15.87	11/16	17.46	16.76	19.30	26.40	7.11	33.77	13.80
DMC6-4G	3/8	9.53	1/4	4.82	3/4	19.05	11/16	17.46	16.76	19.30	31.75	11.18	39.12	18.00
DMC6-6G	3/8	9.53	3/8	7.11	7/8	22.22	11/16	17.46	16.76	19.30	33.02	11.18	40.39	21.80
DMC6-8G	3/8	9.53	1/2	7.11	1-1/16	26.98	11/16	17.46	16.76	19.30	38.86	14.22	46.23	26.00
DMC8-4G	1/2	12.70	1/4	7.11	13/16	20.64	7/8	22.22	22.86	21.84	32.51	11.18	42.67	18.00
DMC8-6G	1/2	12.70	3/8	9.65	7/8	22.22	7/8	22.22	22.86	21.84	33.02	11.18	43.18	21.80
DMC8-8G	1/2	12.70	1/2	10.41	1-1/16	26.98	7/8	22.22	22.86	21.84	38.86	14.22	49.02	26.00
DMC12-8G	3/4	19.05	1/2	11.93	1-1/16	26.98	1-1/8	28.58	24.38	21.84	38.86	14.22	49.02	26.00
DMC12-12G	3/4	19.05	3/4	15.74	1-5/16	33.33	1-1/8	28.58	24.38	21.84	42.67	15.75	52.83	32.00
DMC16-8G	1	25.40	1/2	11.93	1-3/8	34.92	1-1/2	38.10	31.24	26.41	43.69	14.22	55.88	26.00
DMC16-12G	1	25.40	3/4	15.74	1-3/8	34.92	1-1/2	38.10	31.24	26.41	43.69	15.75	55.88	32.00
DMC16-16G	1	25.40	1	22.35	1-5/8	41.27	1-1/2	38.10	31.24	26.41	47.75	18.29	59.94	39.00
DMC20-20G	1-1/4	31.75	1-1/4	27.68	2	50.80	1-7/8	47.63	41.14	38.86	51.16	20.00	73.26	49.00
DMC24-24G	1-1/2	38.10	1-1/2	34.03	2-1/4	57.15	2-1/4	57.15	50.03	45.21	57.57	22.00	84.75	54.70

Male Connector for Metal Gasket (previously DOM) DMC-GB

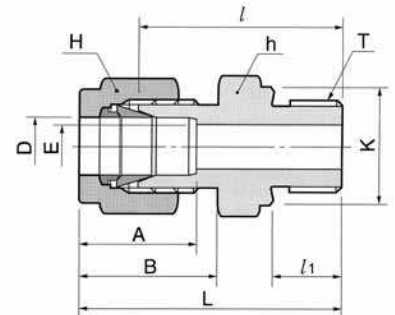
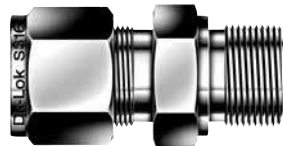

Connects fractional tube to female ISO parallel thread

Part No.	Tube O.D.		T PF	E Min.	Width across flat				A	B	l	l ₁	L	K
	in	mm			in	mm	in	mm						
DMC 2-2GB	1/8	3.17	1/8	2.28	9/16	14.28	7/16	11.11	12.70	15.24	23.37	7.11	29.97	13.72
DMC 2-4GB	1/8	3.17	1/4	2.28	3/4	19.05	7/16	11.11	12.70	15.24	28.70	11.18	35.31	18.03
DMC 2-6GB	1/8	3.17	3/8	2.28	7/8	22.22	7/16	11.11	12.70	15.24	29.72	11.18	36.21	21.84
DMC 4-2GB	1/4	6.35	1/8	2.28	9/16	14.28	9/16	14.28	15.24	17.78	24.89	7.11	32.26	13.72
DMC 4-4GB	1/4	6.35	1/4	4.82	3/4	19.05	9/16	14.28	15.24	17.78	30.23	11.18	37.59	18.03
DMC 4-6GB	1/4	6.35	3/8	4.82	7/8	22.22	9/16	14.28	15.24	17.78	31.50	11.18	38.86	21.84
DMC 4-8GB	1/4	6.35	1/2	4.82	1-1/16	26.98	9/16	14.28	15.24	17.78	37.34	14.22	44.70	25.91
DMC 6-4GB	3/8	9.53	1/4	4.82	3/4	19.05	11/16	17.46	16.76	19.30	31.75	11.18	39.12	18.03
DMC 6-6GB	3/8	9.53	3/8	7.11	7/8	22.22	11/16	17.46	16.76	19.30	33.02	11.18	40.39	21.84
DMC 6-8GB	3/8	9.53	1/2	7.11	1-1/16	26.98	11/16	17.46	16.76	19.30	38.86	14.22	46.23	25.91
DMC 8-4GB	1/2	12.70	1/4	7.11	13/16	20.64	7/8	22.22	22.86	21.84	32.51	11.18	42.67	18.03
DMC 8-6GB	1/2	12.70	3/8	9.65	7/8	22.22	7/8	22.22	22.86	21.84	33.02	11.18	43.18	21.84
DMC 8-8GB	1/2	12.70	1/2	10.41	1-1/16	26.98	7/8	22.22	22.86	21.84	38.86	14.22	49.02	25.91
DMC 12-8GB	3/4	19.05	1/2	11.93	1-1/16	26.98	1-1/8	28.58	24.38	21.84	38.86	14.22	49.02	25.91
DMC 12-12GB	3/4	19.05	3/4	15.74	1-5/16	33.33	1-1/8	28.58	24.38	21.84	42.67	15.75	52.83	32.00
DMC 16-8GB	1	25.40	1/2	11.93	1-3/8	34.92	1-1/2	38.10	31.24	26.41	43.69	14.22	55.88	25.91
DMC 16-16GB	1	25.40	1	22.35	1-5/8	41.27	1-1/2	38.10	31.24	26.41	47.75	18.29	59.94	39.12
DMC 20-20GB	1-1/4	31.75	1-1/4	27.68	2	50.80	1-7/8	47.63	41.14	38.86	51.16	20.00	73.26	49.00
DMC 24-24GB	1-1/2	38.10	1-1/2	34.03	2-1/4	57.15	2-1/4	57.15	50.03	45.21	57.57	22.00	84.75	54.70

Dk-Lok Tube Fittings

Male Connector for Metal Gasket (previously DOM) DMC-GB

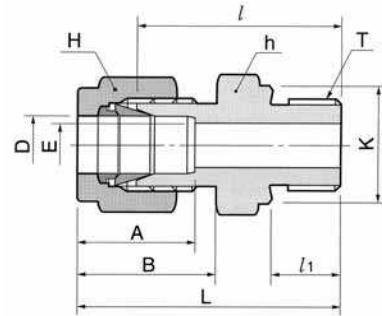
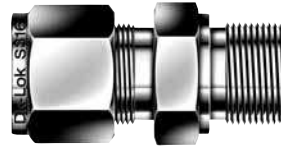

Connects metric tube to female ISO parallel thread

Part No.	Tube O.D. D	T PF	E Min.	Width across flat		A	B	l	l ₁	L	K
				h	H						
DMC3M-2GB	2	1/8	1.7	14	12	12.9	15.3	23.4	7.1	30.0	13.8
DMC3M-4GB	3	1/8	2.4	14	12	12.9	15.3	23.4	7.1	30.0	13.8
DMC4M-2GB	3	1/4	2.4	19	12	12.9	15.3	28.7	11.2	35.3	18.0
DMC6M-2GB	4	1/8	2.4	14	12	13.7	16.1	24.1	7.1	30.7	13.8
DMC6M-4GB	4	1/4	2.4	19	12	13.7	16.1	29.4	11.2	36.0	18.0
DMC6M-6GB	6	1/8	4.0	14	14	15.3	17.7	24.9	7.1	32.3	13.8
DMC6M-8GB	6	1/4	4.8	19	14	15.3	17.7	30.2	11.2	37.6	18.0
DMC8M-2GB	6	3/8	4.8	22	14	15.3	17.7	31.5	11.2	38.9	21.8
DMC8M-4GB	6	1/2	4.8	27	14	15.3	17.7	37.3	14.2	44.7	26.0
DMC8M-6GB	8	1/8	4.0	15	16	16.2	18.6	25.7	7.1	33.2	13.8
DMC8M-8GB	8	1/4	6.4	19	16	16.2	18.6	31.0	11.2	38.5	13.8
DMC10M-4GB	8	3/8	6.4	22	16	16.2	18.6	32.3	11.2	39.8	21.8
DMC10M-6GB	8	1/2	6.4	27	16	16.2	18.6	38.1	14.2	45.6	26.0
DMC10M-8GB	10	1/4	6.4	19	19	17.2	19.5	31.8	11.2	39.4	18.0
DMC12M-4GB	10	3/8	7.9	22	19	17.2	19.5	33.0	11.2	40.6	21.8
DMC12M-6GB	10	1/2	7.9	27	19	17.2	19.5	38.9	14.2	46.5	26.0
DMC12M-8GB	12	1/4	5.9	22	22	22.8	22.0	32.5	11.2	42.6	18.0
DMC12M-12GB	12	3/8	7.9	22	22	22.8	22.0	33.0	11.2	43.1	21.8
DMC15M-8GB	12	1/2	9.5	27	22	22.8	22.0	38.9	14.2	49.0	26.0
DMC16M-6GB	12	3/4	9.5	32	22	22.8	22.0	42.7	15.2	52.8	32.0
DMC16M-8GB	16	3/8	7.9	24	25	24.4	22.0	33.8	11.2	43.9	21.8
DMC18M-8GB	16	1/2	11.9	27	25	24.4	22.0	38.9	14.2	49.0	26.0
DMC18M-12GB	18	1/2	11.9	27	30	24.4	22.0	38.9	14.2	49.0	26.0
DMC20M-8GB	18	3/4	15.1	35	30	24.4	22.0	42.7	15.7	52.8	32.0
DMC20M-12GB	20	1/2	11.9	30	32	26.0	22.0	40.4	14.2	50.5	26.0
DMC22M-12GB	20	3/4	15.9	35	32	26.0	22.0	42.7	15.7	52.8	32.0
DMC22M-16GB	22	3/4	15.9	35	32	26.0	22.0	42.7	15.7	52.8	32.0
DMC25M-12GB	22	1	18.3	41	32	26.0	22.0	45.2	18.3	55.3	39.0
DMC25M-16GB	25	3/4	15.9	35	38	31.3	26.5	45.2	15.7	57.5	32.0
DMC28M-16GB	25	1	19.8	41	38	31.3	26.5	47.8	18.3	60.1	39.0
DMC28M-20GB	28	1	19.8	41	46	36.6	36.6	49.3	18.3	70.1	39.0
DMC30M-20GB	28	1-1/4	21.8	50	46	36.6	36.6	53.1	19.8	73.9	49.0
DMC32M-20GB	32	1-1/4	25.0	50	50	42.0	41.6	55.9	19.8	78.9	49.0
DMC38M-24GB	38	1-1/2	31.8	55	60	49.4	47.9	63.2	22.1	90.8	54.7

ISO Pipe Thread

The International Standards Organization prepares the ISO 228-1 and ISO 7-1 international standard to standardize the nomenclature of several international pipe threads.

ISO 228-1

ISO 228-1 represents internal and external parallel pipe threads where pressure-tight joints are not made on the threads. Compressing two tightening surfaces outside the threads or interposing a gasket seal will make the internal and external thread assembly pressure-tight joint.

ISO 228-1 standardizes the following international pipe threads.

1. BS 2779 (BSPP)
2. DIN-ISO 228/1
3. JIS B0202 (PF)

A self-centering taper is constructed at male thread end. This taper centers a bonded gasket to seal up on the face of the female threaded component.

DGB: NBR inner ring bonded to carbon steel outer ring.

DGV: FKM inner ring bonded to stainless steel outer ring.

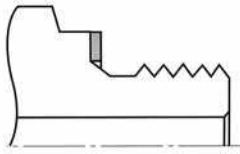

Sealing by compression against face of the female threaded component.

Reference DIN 3852 Form A

See page on 8

for G end connection

Part Number		E		H		D	
		(mm)	(in.)	(mm)	(in.)	(mm)	(in.)
DGB-2-C	DGV-2-S	10.4	0.41	2.0	0.08	16.0	0.63
DGB-4-C	DGV-4-S	13.7	0.54	2.0	0.08	20.6	0.81
DGB-6-C	DGV-6-S	17.3	0.68	2.0	0.08	23.9	0.94
DGB-8-C	DGV-8-S	21.6	0.85	2.5	0.10	28.7	1.13
DGB-12-C	DGV-12-S	26.9	1.06	2.5	0.10	35.1	1.38
DGB-16-C	DGV-16-S	33.8	1.33	2.5	0.10	42.9	1.69
DGB-20-C	DGV-20-S	42.4	1.67	2.5	0.10	51.05	2.01
DGB-24-C	DGV-24-S	48.8	1.92	2.5	0.10	59.18	2.33

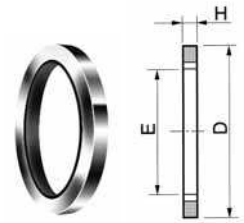

A metal gasket performs the sealing between the reverse bevel of the fitting and the face of the female threaded component.

DGC Copper Gasket

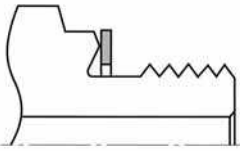

Sealing by gasket.

Reference DIN 3852 Form B

See page on 8

for GB end connection

Part Number	E		H		D	
	(mm)	(in.)	(mm)	(in.)	(mm)	(in.)
DGC-2	9.9	0.39	1.0	0.04	15.0	0.59
DGC-4	13.2	0.52	1.5	0.06	19.1	0.75
DGC-6	16.8	0.66	1.5	0.06	23.1	0.91
DGC-8	21.1	0.83	1.5	0.06	26.9	1.06
DGC-12	26.7	1.05	2.0	0.08	33.0	1.30
DGC-16	33.3	1.31	2.0	0.08	40.1	1.58
DGC-20	42.2	1.66	2.0	0.08	49.8	1.96
DGC-24	48.0	1.89	2.0	0.08	58.4	2.30

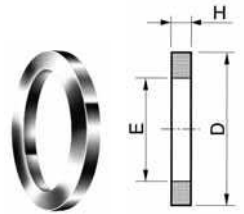

A gasket is dropped into the flat bottom of the female thread. The face of the male thread exerts a load on the gasket to seal.

DGG Copper Gasket

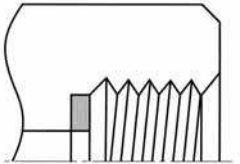

Sealing by gasket.

Reference DIN 3852 Type Y

See page on 8

for GY end connection

Part Number	E		H		D	
	(mm)	(in.)	(mm)	(in.)	(mm)	(in.)
DGG-4-	7.6	0.30	1.8	0.07	10.7	0.42
DGG-6-	8.6	0.34	2.3	0.09	14.2	0.56
DGG-8-	9.1	0.36	2.5	0.10	17.8	0.70

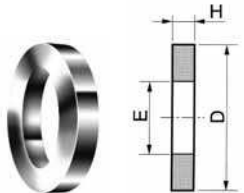

Gasket Temperature Ratings	Gasket		Material		Ratings	
	DGB		NBR		-40 to 110°C (-40 to 230°F)	
	DGV		FKM		-28 to 204°C (-20 to 400°F)	
	DGC, DGG		Copper		-198 to 204°C (-325 to 400°F)	

Dk-Lok Tube Fittings

ISO Internal Parallel Pipe Thread

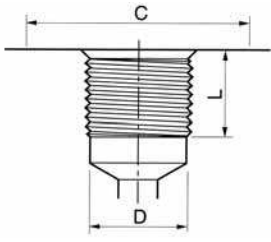

Dk-Lok Pipe Thread Designator	ISO Female Parallel Pipe Size	Minimum Full Thread Depth L	Thread Minor Diameter D	Minimum Flat Diameter for DGB & DGC C
2	1/8	0.31	0.337 / 0.348	0.59
4	1/4	0.47	0.450 / 0.468	0.75
6	3/8	0.47	0.588 / 0.606	0.91
8	1/2	0.55	0.733 / 0.755	1.06
12	3/4	0.63	0.949 / 0.971	1.30
16	1	0.71	1.193 / 1.218	1.58

ISO 7-1

ISO 7-1 represents internal and external pipe tapered threads where pressure-tight joints are made by interference fit. This thread requires sealant to fill the voids between male and female threads that also prevents galling on threads. The sealant usually contains lubricant.

ISO 7-1 standardizes the following international pipe threads.

1. BS 21(BSPT)
2. JIS B0203(PT)
3. DIN 2999 (male thread only)

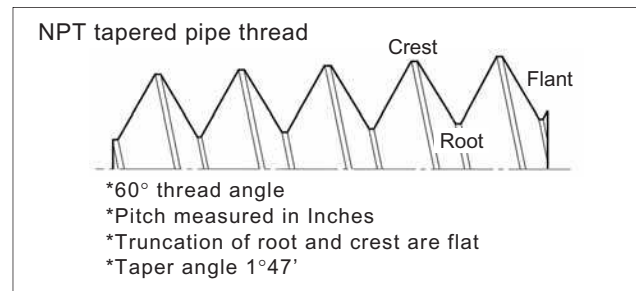
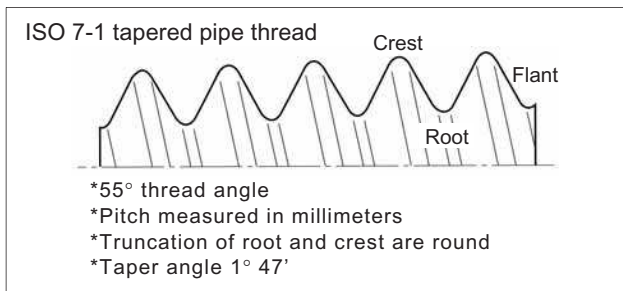

Bulkhead Male Connector DMCB-N

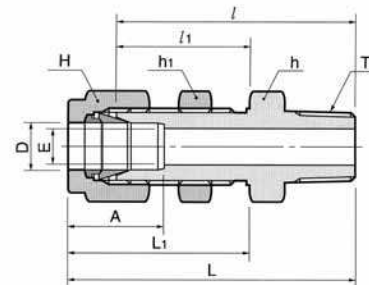
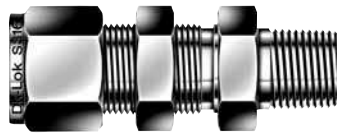

Connects fractional tube to female NPT thread

Part No.	Tube O.D.		T NPT	E Min.	Width across flat			A	l	l ₁	L	L ₁	Panel Hole Drill size	Panel Max Thickness			
	D in	D mm			h in	h ₁ mm	H mm										
DMCB 2-2N	1/8	3.17	1/8	2.28	1/2	12.70	1/2	12.70	7/16	11.11	12.70	39.87	24.63	46.48	31.24	8.33	12.70
DMCB 4-2N	1/4	6.35	1/8	4.82	5/8	15.87	5/8	15.87	9/16	14.28	15.24	42.16	26.16	49.53	33.52	11.50	10.16
DMCB 4-4N	1/4	6.35	1/4	4.82	5/8	15.87	5/8	15.87	9/16	14.28	15.24	45.97	26.16	53.34	33.52	11.50	10.16
DMCB 4-6N	1/4	6.35	3/8	4.8	3/4	19.05	5/8	15.87	9/16	14.28	15.24	45.97	26.16	53.34	33.52	11.50	10.16
DMCB 4-8N	1/4	6.35	1/2	4.8	7/8	22.22	5/8	15.87	9/16	14.28	15.24	53.08	26.16	60.45	33.52	11.50	10.16
DMCB 6-4N	3/8	9.52	1/4	7.11	3/4	19.05	3/4	19.05	11/16	17.46	16.76	50.03	29.46	57.40	36.83	14.68	11.17
DMCB 6-6N	3/8	9.52	3/8	7.11	3/4	19.05	3/4	19.05	11/16	17.46	16.76	50.03	29.46	57.40	36.83	14.68	11.17
DMCB 6-8N	3/8	9.52	1/2	7.11	7/8	22.22	3/4	19.05	11/16	17.46	16.76	56.38	29.46	63.75	36.83	14.68	11.17
DMCB 8-6N	1/2	12.70	3/8	9.39	15/16	23.81	15/16	23.81	7/8	22.22	22.86	53.08	31.75	63.24	41.91	19.44	12.70
DMCB 8-8N	1/2	12.70	1/2	10.41	15/16	23.81	15/16	23.81	7/8	22.22	22.86	58.67	31.75	68.83	41.91	19.44	12.70
DMCB 10-6N	5/8	15.87	3/8	7.93	1-1/16	26.98	1-1/16	26.98	1	25.4	24.38	54.52	32.51	64.68	42.67	22.62	12.70
DMCB 12-12N	3/4	19.05	3/4	15.74	1-3/16	30.16	1-3/16	30.16	1-1/8	28.58	24.38	66.04	37.33	76.20	47.49	25.76	16.76
DMCB 16-16N	1	25.40	1	22.35	1-5/8	41.28	1-5/8	41.28	1-1/2	38.10	31.24	81.02	45.21	93.21	57.40	33.73	19.05
DMCB 20-20N	1-1/4	31.75	1-1/4	27.68	1-7/8	47.63	1-7/8	47.63	1-7/8	47.63	41.14	85.97	47.75	108.07	69.85	41.67	19.05
DMCB 24-24N	1-1/2	38.10	1-1/2	34.03	2-1/4	57.15	2-1/4	57.15	2-1/4	57.15	50.03	93.03	49.27	120.21	76.45	49.61	19.05
DMCB 32-32N	2	50.80	2	45.97	2-3/4	69.85	2-3/4	69.85	3	76.20	67.56	107.29	56.38	144.62	93.71	16.27	19.05

Bulkhead Male Connector DMCB-N

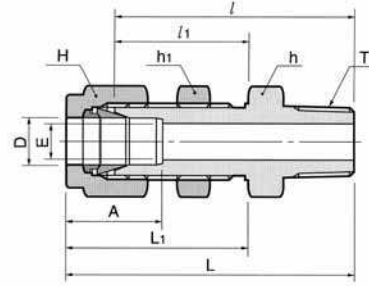
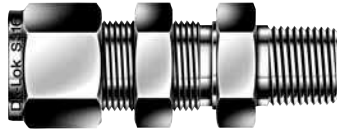

Connects metric tube to female NPT thread

Part No.	Tube O.D.		T NPT	E Min.	Width across flat			A	l	l ₁	L	L ₁	Panel Hole Drill size	Panel Max Thickness
	D				h	h ₁	H							
DMCB 6M-2N	6		1/8	4.8	16	16	14	15.3	42.2	26.2	49.6	33.6	11.5	10.2
DMCB 6M-4N	6		1/4	4.8	16	16	14	15.3	46.2	26.2	53.6	33.6	11.5	10.2
DMCB 6M-6N	6		3/8	4.8	16	16	14	15.3	46.2	26.2	53.6	33.6	11.5	10.2
DMCB 6M-8N	6		1/2	4.8	16	16	14	15.3	52.6	26.2	60.0	33.6	11.5	10.2
DMCB 8M-6N	8		3/8	6.4	18	18	16	16.2	50.0	28.6	57.5	36.1	13.1	11.2
DMCB 10M-4N	10		1/4	7.1	22	22	19	17.2	50.0	29.4	57.5	37.0	16.2	11.2
DMCB 10M-6N	10		3/8	7.9	22	22	19	17.2	50.0	29.4	57.5	37.0	16.2	11.2
DMCB 10M-8N	10		1/2	7.9	22	22	19	17.2	55.9	29.4	63.5	37.0	16.2	11.2
DMCB 12M-6N	12		3/8	9.8	24	24	22	22.8	53.3	31.8	63.4	41.9	19.5	12.7
DMCB 12M-8N	12		1/2	9.8	24	24	22	22.8	58.7	31.8	68.8	41.9	19.5	12.7

45° Male Elbow DLBM

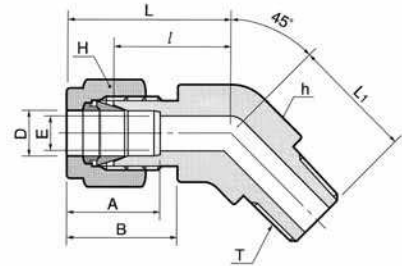
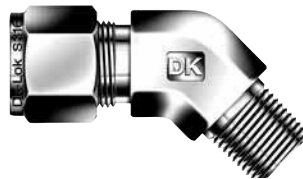

Connects fractional tube to female NPT thread

Part No.	Tube O.D.		T NPT	E Min.	Width across flat				A	B	l	L	L ₁
	in	mm			h	mm	in	mm					
DLBM 2-2N	1/8	3.17	1/8	2.4	1/2	12.70	7/16	11.11	12.70	15.24	15.77	22.38	16.51
DLBM 4-2N	1/4	6.35	1/8	4.82	1/2	12.70	9/16	14.28	15.24	17.78	17.27	24.63	16.51
DLBM 4-4N	1/4	6.35	1/4	4.82	1/2	12.70	9/16	14.28	15.24	17.78	17.27	24.63	21.08
DLBM 6-2N	3/8	9.52	1/8	4.82	5/8	15.87	11/16	17.46	16.76	19.30	20.57	27.94	18.28
DLBM 6-4N	3/8	9.52	1/4	7.11	5/8	15.87	11/16	17.46	16.76	19.30	20.57	27.94	22.86
DLBM 6-6N	3/8	9.52	3/8	7.11	13/16	20.64	11/16	17.46	16.76	19.30	21.84	29.21	24.13
DLBM 8-6N	1/2	12.70	3/8	9.65	13/16	20.64	7/8	22.22	22.86	21.84	21.84	32.00	24.13
DLBM 8-8N	1/2	12.70	1/2	10.41	13/16	20.64	7/8	22.22	22.86	21.84	21.84	32.00	28.95
DLBM 12-12N	3/4	19.05	3/4	15.74	1-1/8	28.58	1-1/8	28.58	24.38	21.84	23.87	34.03	30.98
DLBM 16-16N	1	25.40	1	22.35	1-3/8	34.93	1-1/2	38.10	31.24	26.41	28.19	40.38	37.84

Connects metric tube to female NPT thread

Part No.	Tube O.D.		T NPT	E Min.	Width across flat		A	B	l	L	L ₁
	D				h	H					
DLBM 6M-4N	6		1/4	4.8	12.7	14.0	15.3	17.7	21.8	29.4	22.9
DLBM 12M-8N	12		1/2	9.5	20.64	22.0	22.8	22.0	21.8	31.9	29.0

Dk-Lok Tube Fittings

Male Elbow DLM-N

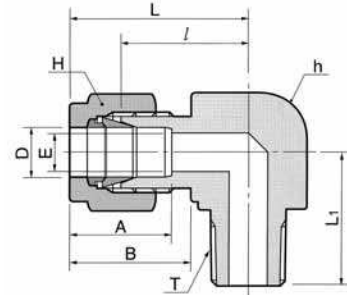

Connects fractional tube to female NPT thread

Part No.	Tube O.D. D		T NPT	E Min.	Width across flat				A	B	l	L	L1
	in	mm			h	mm	in	H					
DLM 1-1N	1/16	1.59	1/16	1.27	7/16	11.11	5/16	7.93	8.63	10.92	15.24	19.05	17.78
DLM 1-2N	1/16	1.59	1/8	1.27	7/16	11.11	5/16	7.93	8.63	10.92	15.24	19.05	17.78
DLM 2-1N	1/8	3.17	1/16	2.28	7/16	11.11	7/16	11.11	12.70	15.24	17.02	23.63	17.78
DLM 2-2N	1/8	3.17	1/8	2.28	1/2	12.70	7/16	11.11	12.70	15.24	18.30	24.91	18.90
DLM 2-4N	1/8	3.17	1/4	2.28	1/2	12.70	7/16	11.11	12.70	15.24	18.30	24.91	23.26
DLM 3-2N	3/16	4.76	1/8	3.04	1/2	12.70	1/2	12.70	13.71	16.00	18.79	25.40	18.79
DLM 3-4N	3/16	4.76	1/4	3.04	1/2	12.70	1/2	12.70	13.71	16.00	18.79	25.40	23.36
DLM 4-1N	1/4	6.35	1/16	3.04	1/2	12.70	9/16	14.28	15.24	17.78	19.55	26.90	18.79
DLM 4-2N	1/4	6.35	1/8	4.82	1/2	12.70	9/16	14.28	15.24	17.78	19.55	26.47	18.79
DLM 4-4N	1/4	6.35	1/4	4.82	1/2	12.70	9/16	14.28	15.24	17.78	19.81	27.18	23.87
DLM 4-6N	1/4	6.35	3/8	4.82	11/16	17.46	9/16	14.28	15.24	17.78	22.35	29.71	26.20
DLM 4-8N	1/4	6.35	1/2	4.82	13/16	20.64	9/16	14.28	15.24	17.78	24.60	31.97	33.02
DLM 5-2N	5/16	7.93	1/8	4.82	9/16	14.28	5/8	15.87	16.25	18.54	21.33	28.70	19.81
DLM 5-4N	5/16	7.93	1/4	6.35	9/16	14.28	5/8	15.87	16.25	18.54	21.33	29.77	24.50
DLM 5-6N	5/16	7.93	3/8	6.35	11/16	17.46	5/8	15.87	16.25	18.54	23.11	30.48	26.20
DLM 6-2N	3/8	9.52	1/8	4.82	5/8	15.87	11/16	17.46	16.76	19.30	23.11	30.48	20.60
DLM 6-4N	3/8	9.52	1/4	7.11	5/8	15.87	11/16	17.46	16.76	19.30	23.11	30.48	25.40
DLM 6-6N	3/8	9.52	3/8	7.11	11/16	17.46	11/16	17.46	16.76	19.30	23.87	31.24	26.20
DLM 6-8N	3/8	9.52	1/2	7.11	13/16	20.64	11/16	17.46	16.76	19.30	25.90	31.42	33.02
DLM 6-12N	3/8	9.52	3/4	7.11	1-1/16	26.98	11/16	17.46	16.76	19.30	29.71	37.08	36.83
DLM 8-4N	1/2	12.70	1/4	7.11	13/16	20.64	7/8	22.22	22.86	21.84	25.90	36.06	28.30
DLM 8-6N	1/2	12.70	3/8	9.65	13/16	20.64	7/8	22.22	22.86	21.84	25.90	36.06	28.30
DLM 8-8N	1/2	12.70	1/2	10.41	13/16	20.64	7/8	22.22	22.86	21.84	25.90	36.06	33.02
DLM 8-12N	1/2	12.70	3/4	10.41	1-1/16	26.98	7/8	22.22	22.86	21.84	29.71	39.87	36.83
DLM 10-6N	5/8	15.87	3/8	9.65	15/16	23.81	1	25.40	24.38	21.84	28.00	37.06	30.22
DLM 10-8N	5/8	15.87	1/2	11.93	15/16	23.81	1	25.40	24.38	21.84	28.00	37.06	35.10
DLM 10-12N	5/8	15.87	3/4	12.70	1-1/16	26.98	1	25.40	24.38	21.84	29.71	39.87	36.83
DLM 12-8N	3/4	19.05	1/2	11.93	1-1/16	26.98	1-1/8	28.57	24.38	21.84	29.71	39.87	37.00
DLM 12-12N	3/4	19.05	3/4	15.74	1-1/16	26.98	1-1/8	28.57	24.38	21.84	29.71	39.87	36.83
DLM 14-12N	7/8	22.22	3/4	15.74	1-3/8	34.92	1-1/4	31.75	25.90	21.84	34.54	44.70	41.65
DLM 16-12N	1	25.40	3/4	15.74	1-3/8	34.92	1-1/2	38.10	31.24	26.41	36.83	49.02	42.20
DLM 16-16N	1	25.40	1	22.35	1-3/8	34.92	1-1/2	38.10	31.24	26.41	36.83	49.02	46.70
DLM 20-20N	1-1/4	31.75	1-1/4	27.68	1-11/16	42.86	1-7/8	47.63	41.14	38.86	44.50	66.54	47.75
DLM 24-24N	1-1/2	38.10	1-1/2	34.03	2	50.80	2-1/4	57.15	50.03	45.21	50.80	77.97	60.45
DLM 32-32N	2	50.80	2	45.97	2-3/4	69.85	3	76.20	62.73	63.73	69.80	107.18	70.61

Male Elbow DLM-N

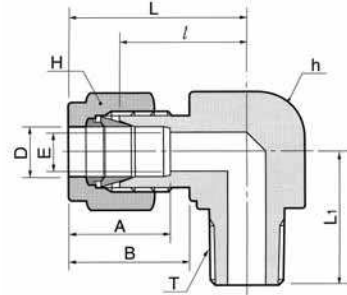

Connects metric tube to female NPT thread

Part No.	Tube O.D. D	T NPT	E Min.	Width across flat		A	B	l	L	L1
				h	H					
DLM 3M-1N	3	1/16	2.4	11.1	12	12.9	15.3	17.0	23.6	17.8
DLM 3M-2N	3	1/8	2.4	12.7	12	12.9	15.3	17.0	23.6	17.8
DLM 3M-4N	3	1/4	2.4	12.7	12	12.9	15.3	18.0	24.6	23.4
DLM 4M-2N	4	1/8	2.4	12.7	12	13.7	16.1	18.8	25.4	18.8
DLM 4M-4N	4	1/4	2.4	12.7	12	13.7	16.1	18.8	25.4	23.4
DLM 6M-2N	6	1/8	4.8	12.7	14	15.3	17.7	19.6	27.0	18.8
DLM 6M-4N	6	1/4	4.8	12.7	14	15.3	17.7	19.6	27.0	23.4
DLM 6M-6N	6	3/8	4.8	17.5	14	15.3	17.7	22.4	29.8	26.2
DLM 6M-8N	6	1/2	4.8	20.6	14	15.3	17.7	24.4	31.8	33.0
DLM 8M-2N	8	1/8	4.8	14.3	16	16.2	18.6	21.3	28.8	19.8
DLM 8M-4N	8	1/4	6.4	14.3	16	16.2	18.6	21.3	28.8	24.4
DLM 8M-6N	8	3/8	6.4	17.5	16	16.2	18.6	23.1	30.6	26.2
DLM 8M-8N	8	1/2	6.4	20.6	16	16.2	18.6	25.1	32.6	33.0
DLM 10M-2N	10	1/8	4.8	17.5	19	17.2	19.5	23.9	31.5	23.6
DLM 10M-4N	10	1/4	7.1	17.5	19	17.2	19.5	23.9	31.5	26.2
DLM 10M-6N	10	3/8	7.9	17.5	19	17.2	19.5	23.9	31.5	26.2
DLM 10M-8N	10	1/2	7.9	20.6	19	17.2	19.5	25.9	33.5	33.0
DLM 12M-4N	12	1/4	7.1	20.6	22	22.8	22.0	25.9	36.0	28.2
DLM 12M-6N	12	3/8	9.5	20.6	22	22.8	22.0	25.9	36.0	28.2
DLM 12M-8N	12	1/2	9.5	20.6	22	22.8	22.0	25.9	36.0	33.0
DLM 12M-12N	12	3/4	9.5	27.0	22	22.8	22.0	29.7	39.8	36.8
DLM 15M-6N	15	3/8	9.5	23.81	25	24.4	22.0	27.9	38.0	30.2
DLM 15M-8N	15	1/2	11.9	23.81	25	24.4	22.0	27.9	38.0	35.1
DLM 16M-6N	16	3/8	9.5	25.4	25	24.4	22.0	27.9	38.0	30.2
DLM 16M-8N	16	1/2	11.9	23.81	25	24.4	22.0	27.9	38.0	35.1
DLM 16M-12N	16	3/4	12.7	23.81	25	24.4	22.0	29.7	39.8	36.8
DLM 18M-8N	18	1/2	11.9	27.0	30	24.4	22.0	29.7	39.8	36.8
DLM 18M-12N	18	3/4	15.1	27.0	30	24.4	22.0	29.7	39.8	36.8
DLM 20M-8N	20	1/2	11.9	34.9	32	26.0	22.0	34.5	44.6	41.7
DLM 20M-12N	20	3/4	15.9	34.9	32	26.0	22.0	34.5	44.6	41.7
DLM 22M-8N	22	1/2	11.9	34.9	32	26.0	22.0	32.5	42.6	39.6
DLM 22M-12N	22	3/4	15.9	34.9	32	26.0	22.0	34.5	44.6	41.7
DLM 22M-16N	22	1	18.3	34.9	32	26.0	22.0	34.5	44.6	46.5
DLM 25M-12N	25	3/4	15.9	34.9	38	31.3	26.5	36.8	49.1	41.7
DLM 25M-16N	25	1	21.8	34.9	38	31.3	26.5	36.8	49.1	46.5
DLM 28M-16N	28	1	21.8	41.0	46	36.6	36.6	43.2	64.0	53.7
DLM 30M-20N	30	1-1/4	26.2	46.0	50	39.6	39.2	48.3	69.9	53.1
DLM 32M-20N	32	1-1/4	27.8	46.0	50	42.0	41.6	49.3	72.3	53.1
DLM 38M-24N	38	1-1/4	33.7	55.0	60	49.4	47.9	56.4	84.0	60.4

Dk-Lok Tube Fittings

Male Elbow DLM-R

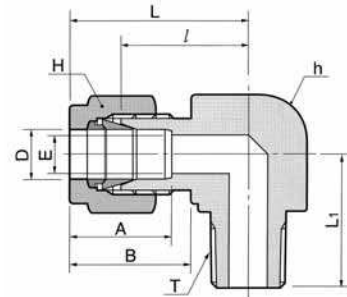

Connects fractional tube to female ISO tapered thread

Part No.	Tube O.D. D		T PT	E Min.	Width across flat				A	B	l	L	L1
	in	mm			h	mm	in	H					
DLM 2-2R	1/8	3.17	1/8	2.28	1/2	12.70	7/16	11.11	12.70	15.24	18.30	24.91	18.90
DLM 2-4R	1/8	3.17	1/4	2.28	1/2	12.70	7/16	11.11	12.70	15.24	18.30	24.91	23.26
DLM 3-4R	3/16	4.76	1/4	3.04	1/2	12.70	1/2	12.70	13.71	16.00	18.79	25.40	23.36
DLM 4-2R	1/4	6.35	1/8	4.82	1/2	12.70	9/16	14.28	15.24	17.78	19.55	26.47	18.79
DLM 4-4R	1/4	6.35	1/4	4.82	1/2	12.70	9/16	14.28	15.24	17.78	19.81	27.18	23.87
DLM 4-6R	1/4	6.35	3/8	4.82	11/16	17.46	9/16	14.28	15.24	17.78	22.35	29.71	26.20
DLM 4-8R	1/4	6.35	1/2	4.82	13/16	20.64	9/16	14.28	15.24	17.78	24.60	31.97	33.02
DLM 5-4R	5/16	7.93	1/4	6.35	9/16	14.28	5/8	15.87	16.25	18.54	21.33	29.77	24.50
DLM 5-6R	5/16	7.93	3/8	6.35	11/16	17.46	5/8	15.87	16.25	18.54	23.11	30.48	26.20
DLM 6-2R	3/8	9.52	1/8	4.82	5/8	15.87	11/16	17.46	16.76	19.30	23.11	30.48	20.60
DLM 6-4R	3/8	9.52	1/4	7.11	5/8	15.87	11/16	17.46	16.76	19.30	23.11	30.48	25.40
DLM 6-6R	3/8	9.52	3/8	7.11	11/16	17.46	11/16	17.46	16.76	19.30	23.87	31.24	26.20
DLM 6-8R	3/8	9.52	1/2	7.11	13/16	20.64	11/16	17.46	16.76	19.30	25.90	31.42	33.02
DLM 6-12R	3/8	9.52	3/4	7.11	1-1/16	26.98	11/16	17.46	16.76	19.30	29.71	37.08	36.83
DLM 8-4R	1/2	12.70	1/4	7.11	13/16	20.64	7/8	22.22	22.86	21.84	25.90	36.06	28.30
DLM 8-6R	1/2	12.70	3/8	9.65	13/16	20.64	7/8	22.22	22.86	21.84	25.90	36.06	28.30
DLM 8-8R	1/2	12.70	1/2	10.41	13/16	20.64	7/8	22.22	22.86	21.84	25.90	36.06	33.02
DLM 8-12R	1/2	12.70	3/4	10.41	1-1/16	26.98	7/8	22.22	22.86	21.84	29.71	39.87	36.83
DLM 10-6R	5/8	15.87	3/8	9.65	15/16	23.81	1	25.40	24.38	21.84	28.00	37.06	30.22
DLM 10-8R	5/8	15.87	1/2	11.93	15/16	23.81	1	25.40	24.38	21.84	28.00	37.06	35.10
DLM 10-12R	5/8	15.87	3/4	12.70	1-1/16	26.98	1	25.40	24.38	21.84	29.71	39.87	36.83
DLM 12-8R	3/4	19.05	1/2	11.93	1-1/16	26.98	1-1/8	28.57	24.38	21.84	29.71	39.87	37.00
DLM 12-12R	3/4	19.05	3/4	15.74	1-1/16	26.98	1-1/8	28.57	24.38	21.84	29.71	39.87	36.83
DLM 12-16R	3/4	19.05	1	16.0	1-3/8	34.92	1-1/8	28.57	24.38	21.84	34.54	44.59	46.48
DLM 16-12R	1	25.40	3/4	15.74	1-3/8	34.92	1-1/2	38.10	31.24	26.41	36.83	49.02	42.20
DLM 16-16R	1	25.40	1	22.35	1-3/8	34.92	1-1/2	38.10	31.24	26.41	36.83	49.02	46.70
DLM 20-12R	1-1/4	31.75	3/4	15.74	1-11/16	42.86	1-7/8	47.63	41.14	38.86	44.50	66.54	42.95
DLM 20-20R	1-1/4	31.75	1-1/4	27.68	1-11/16	42.86	1-7/8	47.63	41.14	38.86	44.50	66.54	47.75

Male Elbow DLM-R

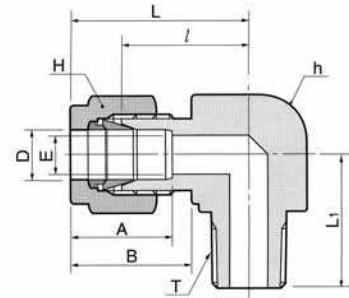
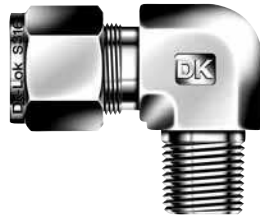

Connects metric tube to female ISO tapered thread

Part No.	Tube O.D. D	T PT	E Min.	Width across flat		A	B	l	L	L1
				h	H					
DLM 3M-1R	3	1/16	2.4	11.1	12	12.9	15.3	17.0	23.6	17.8
DLM 3M-2R	3	1/8	2.4	12.7	12	12.9	15.3	17.0	23.6	17.8
DLM 3M-4R	3	1/4	2.4	12.7	12	12.9	15.3	18.0	24.6	23.4
DLM 4M-2R	4	1/8	2.4	12.7	12	13.7	16.1	18.8	25.4	18.8
DLM 4M-4R	4	1/4	2.4	12.7	12	13.7	16.1	18.8	25.4	23.4
DLM 6M-2R	6	1/8	4.8	12.7	14	15.3	17.7	19.6	27.0	18.8
DLM 6M-4R	6	1/4	4.8	12.7	14	15.3	17.7	19.6	27.0	23.4
DLM 6M-6R	6	3/8	4.8	17.5	14	15.3	17.7	22.4	29.8	26.2
DLM 6M-8R	6	1/2	4.8	20.6	14	15.3	17.7	24.4	31.8	33.0
DLM 8M-2R	8	1/8	4.8	14.3	16	16.2	18.6	21.3	28.8	19.8
DLM 8M-4R	8	1/4	6.4	14.3	16	16.2	18.6	21.3	28.8	24.4
DLM 8M-6R	8	3/8	6.4	17.5	16	16.2	18.6	23.1	30.6	26.2
DLM 8M-8R	8	1/2	6.4	20.6	16	16.2	18.6	25.1	32.6	33.0
DLM 10M-2R	10	1/8	4.8	17.5	19	17.2	19.5	23.9	31.5	23.6
DLM 10M-4R	10	1/4	7.1	17.5	19	17.2	19.5	23.9	31.5	26.2
DLM 10M-6R	10	3/8	7.9	17.5	19	17.2	19.5	23.9	31.5	26.2
DLM 10M-8R	10	1/2	7.9	20.6	19	17.2	19.5	25.9	33.5	33.0
DLM 12M-2R	12	1/8	4.8	20.6	22	22.8	22.0	25.9	36.0	23.6
DLM 12M-4R	12	1/4	7.1	20.6	22	22.8	22.0	25.9	36.0	28.2
DLM 12M-6R	12	3/8	9.5	20.6	22	22.8	22.0	25.9	36.0	28.2
DLM 12M-8R	12	1/2	9.5	20.6	22	22.8	22.0	25.9	36.0	33.0
DLM 12M-12R	12	3/4	9.5	27.0	22	22.8	22.0	29.7	39.8	36.8
DLM 14M-8R	14	1/2	11.1	23.81	25	24.4	22.0	27.9	38.0	30.2
DLM 15M-6R	15	3/8	9.5	23.81	25	24.4	22.0	27.9	38.0	30.2
DLM 15M-8R	15	1/2	11.9	23.81	25	24.4	22.0	27.9	38.0	35.1
DLM 16M-6R	16	3/8	9.5	25.4	25	24.4	22.0	27.9	38.0	30.2
DLM 16M-8R	16	1/2	11.9	23.81	25	24.4	22.0	27.9	38.0	35.1
DLM 18M-8R	18	1/2	11.9	27.0	30	24.4	22.0	29.7	39.8	36.8
DLM 18M-12R	18	3/4	15.1	27.0	30	24.4	22.0	29.7	39.8	36.8
DLM 20M-8R	20	1/2	11.9	34.92	32	26.0	22.0	34.5	44.6	41.7
DLM 20M-12R	20	3/4	15.9	34.92	32	26.0	22.0	34.5	44.6	41.7
DLM 22M-8R	22	1/2	11.9	34.92	32	26.0	22.0	32.5	42.6	39.6
DLM 22M-12R	22	3/4	15.9	34.92	32	26.0	22.0	34.5	44.6	41.7
DLM 22M-16R	22	1	18.3	34.92	32	26.0	22.0	34.5	44.6	46.5
DLM 25M-8R	25	1/2	11.9	34.92	38	31.3	26.5	36.8	49.1	41.7
DLM 25M-12R	25	3/4	15.9	34.92	38	31.3	26.5	36.8	49.1	41.7
DLM 25M-16R	25	1	21.8	34.92	38	31.3	26.5	36.8	49.1	46.5
DLM 28M-16R	28	1	21.8	41.0	46	36.6	36.6	43.2	64.0	53.7

Dk-Lok Tube Fittings

Male Run Tee DTRM-N

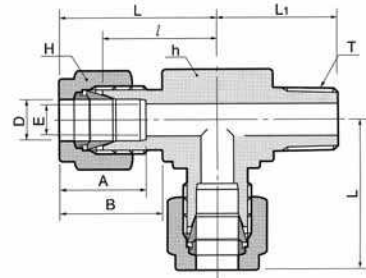
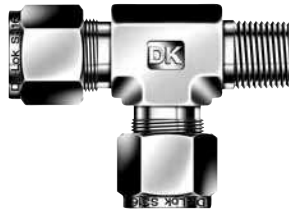

Connects fractional tube to female NPT thread

Part No.	Tube O.D.		T NPT	E Min.	Width across flat				A	B	l	L	L1
	D				h		H						
	in	mm			in	mm	in	mm					
DTRM 1-1N	1/16	1.59	1/16	1.27	7/16	11.11	5/16	7.93	8.63	10.92	15.24	19.05	17.78
DTRM 1-2N	1/16	1.59	1/8	1.27	7/16	11.11	5/16	7.93	8.63	10.92	15.24	19.05	17.78
DTRM 2-2N	1/8	3.17	1/8	2.28	1/2	12.70	7/16	11.11	12.70	15.24	18.30	24.91	18.90
DTRM 2-4N	1/8	3.17	1/4	2.28	1/2	12.70	7/16	11.11	12.70	15.24	18.30	24.91	23.36
DTRM 3-2N	3/16	4.76	1/8	3.04	1/2	12.70	1/2	12.70	13.71	16.00	18.79	24.38	18.79
DTRM 3-4N	3/16	4.76	1/4	3.04	1/2	12.70	1/2	12.70	13.71	16.00	18.79	25.40	23.36
DTRM 4-1N	1/4	6.35	1/16	3.04	1/2	12.70	9/16	14.28	15.24	17.78	19.55	26.90	18.79
DTRM 4-2N	1/4	6.35	1/8	4.82	1/2	12.70	9/16	14.28	15.24	17.78	19.55	26.92	18.79
DTRM 4-4N	1/4	6.35	1/4	4.82	1/2	12.70	9/16	14.28	15.24	17.78	19.55	27.08	23.87
DTRM 4-6N	1/4	6.35	3/8	4.82	11/16	17.46	9/16	14.28	15.24	17.78	22.35	29.71	28.40
DTRM 4-8N	1/4	6.35	1/2	4.82	13/16	20.64	9/16	14.28	15.24	17.78	24.60	31.97	35.10
DTRM 5-2N	5/16	7.93	1/8	4.82	9/16	14.28	5/8	15.87	16.25	18.54	22.35	29.71	19.81
DTRM 5-4N	5/16	7.94	1/4	6.35	9/16	14.28	5/8	15.87	16.25	18.54	22.35	29.77	24.50
DTRM 5-6N	5/16	7.94	3/8	6.35	11/16	17.46	5/8	15.87	16.25	18.54	23.11	30.48	28.40
DTRM 6-4N	3/8	9.52	1/4	7.11	5/8	15.87	1/16	17.46	16.76	19.30	23.11	30.48	25.40
DTRM 6-6N	3/8	9.52	3/8	7.11	11/16	17.46	11/16	17.46	16.76	19.30	23.87	31.24	28.44
DTRM 6-8N	3/8	9.52	1/2	7.11	13/16	20.64	11/16	17.46	16.76	19.30	25.90	33.27	33.02
DTRM 6-12N	3/8	9.52	3/4	7.11	1-1/16	26.98	11/16	17.46	16.76	19.30	29.71	37.08	36.83
DTRM 8-4N	1/2	12.70	1/4	7.11	13/16	20.64	7/8	22.22	22.86	21.84	25.90	36.06	28.30
DTRM 8-6N	1/2	12.70	3/8	9.65	13/16	20.64	7/8	22.22	22.86	21.84	25.90	36.06	28.30
DTRM 8-8N	1/2	12.70	1/2	10.41	13/16	20.64	7/8	22.22	22.86	21.84	25.90	36.06	33.02
DTRM 8-12N	1/2	12.70	3/4	10.41	1-1/16	26.98	7/8	22.22	22.86	21.84	29.71	39.84	36.83
DTRM 10-6N	5/8	15.87	3/8	9.65	15/16	23.81	1	25.40	24.38	21.84	27.90	38.10	29.40
DTRM 10-8N	5/8	15.87	1/2	11.93	15/16	23.81	1	25.40	24.38	21.84	27.90	38.10	34.00
DTRM 10-12N	5/8	15.87	3/4	12.70	1-1/16	26.98	1	25.40	24.38	21.84	29.71	39.87	36.83
DTRM 12-8N	3/4	19.05	1/2	11.93	1-1/16	26.98	1-1/8	28.58	24.38	21.84	29.71	39.87	37.00
DTRM 12-12N	3/4	19.05	3/4	15.74	1-1/16	26.98	1-1/8	28.58	24.38	21.84	29.71	39.81	36.83
DTRM 14-12N	7/8	22.23	3/4	15.74	1-3/8	34.92	1-1/4	31.75	25.90	21.84	34.54	44.70	41.65
DTRM 16-12N	1	25.40	3/4	15.74	1-3/8	34.92	1-1/2	38.10	31.24	26.41	36.83	49.02	42.20
DTRM 16-16N	1	25.40	1	22.35	1-3/8	34.92	1-1/2	38.10	31.24	26.41	36.83	49.02	46.70
DTRM 20-20N	1-1/4	31.75	1-1/4	27.68	1-11/16	42.86	1-7/8	47.63	41.14	38.86	44.50	66.54	47.75
DTRM 24-24N	1-1/2	38.10	1-1/2	34.03	2	50.80	2-1/4	57.15	50.03	45.21	50.80	77.97	60.45
DTRM 32-32N	2	50.80	2	45.97	2-3/4	69.85	3	76.20	67.56	62.73	69.80	107.18	70.61

Male Run Tee DTRM-R

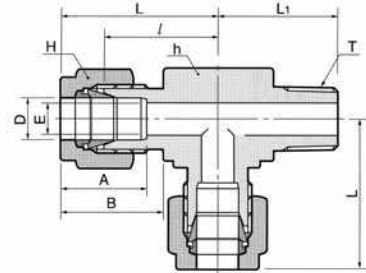
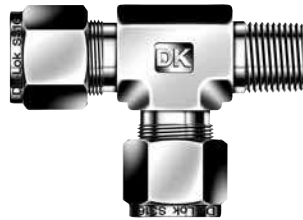

Connects fractional tube to female ISO tapered thread

Part No.	Tube O.D.		T PT	E Min.	Width across flat				A	B	l	L	L1
	in	mm			h	H	in	mm					
DTRM 6-4R	3/8	9.52	1/4	7.11	5/8	15.87	1/16	17.46	16.76	19.30	23.11	30.48	25.40
DTRM 8-6R	1/2	12.70	3/8	9.65	13/16	20.64	7/8	22.22	22.86	21.84	25.90	36.06	28.30
DTRM 8-8R	1/2	12.70	1/2	10.41	13/16	20.64	7/8	22.22	22.86	21.84	25.90	36.06	33.02
DTRM 10-8R	5/8	15.87	1/2	11.93	15/16	23.81	1	25.40	24.38	21.84	27.90	38.10	34.00

Connects metric tube to female ISO tapered thread

Part No.	Tube O.D. D	T PT	E Min.	Width across flat		A	B	l	L	L1
				h	H					
DTRM 3M-2R	3	1/8	2.4	12.7	12	12.9	15.3	17.0	23.6	17.8
DTRM 3M-4R	3	1/4	2.4	12.7	12	12.9	15.3	18.0	24.6	23.4
DTRM 4M-2R	4	1/8	2.4	12.7	12	13.7	16.1	18.8	25.4	18.8
DTRM 4M-4R	4	1/4	2.4	12.7	12	13.7	16.1	18.8	25.4	23.4
DTRM 6M-2R	6	1/8	4.8	12.7	14	15.3	17.7	19.6	27.0	18.8
DTRM 6M-4R	6	1/4	4.8	14.2	14	15.3	17.7	19.6	27.0	23.4
DTRM 6M-6R	6	3/8	4.8	17.5	14	15.3	17.7	22.4	29.8	26.2
DTRM 6M-8R	6	1/2	4.8	20.6	14	15.3	17.7	24.4	31.8	33.0
DTRM 8M-2R	8	1/8	4.8	14.3	16	16.2	18.6	21.3	28.8	19.8
DTRM 8M-4R	8	1/4	6.4	14.3	16	16.2	18.6	21.3	28.8	24.4
DTRM 8M-6R	8	3/8	6.4	17.5	16	16.2	18.6	23.1	30.6	26.2
DTRM 8M-8R	8	1/2	6.4	20.6	16	16.2	18.6	25.1	32.6	33.0
DTRM 10M-2R	10	1/8	4.8	17.5	19	17.2	19.5	23.9	31.5	23.6
DTRM 10M-4R	10	1/4	7.1	17.5	19	17.2	19.5	23.9	31.5	26.2
DTRM 10M-6R	10	3/8	7.9	17.5	19	17.2	19.5	23.9	31.5	26.2
DTRM 10M-8R	10	1/2	7.9	20.6	19	17.2	19.5	25.9	33.5	33.0
DTRM 12M-2R	12	1/8	4.8	20.6	22	22.8	22.0	25.9	36.0	23.6
DTRM 12M-4R	12	1/4	7.1	20.6	22	22.8	22.0	25.9	36.0	28.2
DTRM 12M-6R	12	3/8	9.5	20.6	22	22.8	22.0	25.9	36.0	28.2
DTRM 12M-8R	12	1/2	9.5	20.6	22	22.8	22.0	25.9	36.0	33.0
DTRM 12M-12R	12	3/4	9.5	27.0	22	22.8	22.0	29.7	39.8	36.8
DTRM 16M-6R	16	3/8	9.5	25.4	25	24.4	22.0	27.9	38.0	30.2
DTRM 16M-8R	16	1/2	11.9	25.4	25	24.4	22.0	27.9	38.0	35.1
DTRM 16M-12R	16	3/4	12.7	27.0	25	24.4	22.0	29.7	39.8	36.8
DTRM 18M-8R	18	1/2	11.9	27.0	30	24.4	22.0	29.7	39.8	36.8
DTRM 18M-12R	18	3/4	15.1	27.0	30	24.4	22.0	29.7	39.8	36.8
DTRM 20M-8R	20	1/2	11.9	34.92	32	26.0	22.0	34.5	44.6	41.7
DTRM 20M-12R	20	3/4	15.9	34.92	32	26.0	22.0	34.5	44.6	41.7
DTRM 22M-12R	22	3/4	15.9	34.92	32	26.0	22.0	34.5	44.6	41.7
DTRM 22M-16R	22	1	18.3	34.92	32	26.0	22.0	34.5	44.6	46.5
DTRM 25M-12R	25	3/4	15.9	34.92	38	31.3	26.5	36.8	49.1	41.7
DTRM 25M-16R	25	1	21.8	34.92	38	31.3	26.5	36.8	49.1	46.5

Male Branch Tee DTBM-N, -R

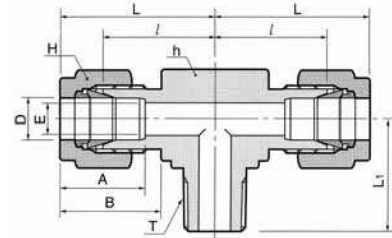

Connects fractional tube to female NPT thread

Part No.	Tube O.D. D		T NPT	E Min.	Width across flat				A	B	l	L	L1
	in	mm			h		H						
DTBM 1-1N	1/16	1.59	1/16	1.27	7/16	11.11	5/16	7.93	8.63	10.92	15.24	19.05	17.78
DTBM 1-2N	1/16	1.59	1/8	1.27	7/16	11.11	5/16	7.93	8.63	10.92	15.24	19.05	17.78
DTBM 2-2N	1/8	3.17	1/8	2.28	1/2	12.70	7/16	11.11	12.70	15.24	18.30	24.91	18.90
DTBM 2-4N	1/8	3.17	1/4	2.28	1/2	12.70	7/16	11.11	12.70	15.24	18.30	24.91	23.36
DTBM 3-2N	3/16	4.76	1/8	3.04	1/2	12.70	1/2	12.70	13.71	16.00	18.79	24.38	18.79
DTBM 3-4N	3/16	4.76	1/4	3.04	1/2	12.70	1/2	12.70	13.71	16.00	18.79	25.40	23.36
DTBM 4-1N	1/4	6.35	1/16	3.04	1/2	12.70	9/16	14.28	15.24	17.78	19.55	26.90	18.79
DTBM 4-2N	1/4	6.35	1/8	4.82	1/2	12.70	9/16	14.28	15.24	17.78	19.55	26.92	19.10
DTBM 4-4N	1/4	6.35	1/4	4.82	1/2	12.70	9/16	14.28	15.24	17.78	19.55	27.08	23.87
DTBM 4-6N	1/4	6.35	3/8	4.82	11/16	17.46	9/16	14.28	15.24	17.78	22.35	29.71	28.40
DTBM 4-8N	1/4	6.35	1/2	4.82	13/16	20.64	9/16	14.28	15.24	17.78	24.60	31.97	35.10
DTBM 5-2N	5/16	7.93	1/8	4.82	9/16	14.28	5/8	15.87	16.25	18.54	22.35	29.71	19.81
DTBM 5-4N	5/16	7.93	1/4	6.35	9/16	14.28	5/8	15.87	16.25	18.54	22.35	29.77	24.50
DTBM 5-6N	5/16	7.93	3/8	6.35	11/16	17.46	5/8	15.87	16.25	18.54	23.11	30.48	28.40
DTBM 6-4N	3/8	9.52	1/4	7.11	5/8	15.87	11/16	17.46	16.76	19.30	23.11	30.48	25.40
DTBM 6-6N	3/8	9.52	3/8	7.11	11/16	17.46	11/16	17.46	16.76	19.30	23.87	31.24	28.44
DTBM 6-8N	3/8	9.52	1/2	7.11	13/16	20.64	11/16	17.46	16.76	19.30	25.90	33.27	33.02
DTBM 6-12N	3/8	9.52	3/4	7.11	1-1/16	26.98	11/16	17.46	16.76	19.30	29.71	37.08	36.83
DTBM 8-4N	1/2	12.70	1/4	7.11	13/16	20.64	7/8	22.22	22.86	21.84	25.90	36.06	28.30
DTBM 8-6N	1/2	12.70	3/8	10.41	13/16	20.64	7/8	22.22	22.86	21.84	25.90	36.06	28.30
DTBM 8-8N	1/2	12.70	1/2	10.41	13/16	20.64	7/8	22.22	22.86	21.84	25.90	36.06	33.02
DTBM 8-12N	1/2	12.70	3/4	10.41	1-1/16	26.98	7/8	22.22	22.86	21.84	29.71	39.87	36.83
DTBM 10-6N	5/8	15.87	3/8	9.65	15/16	23.81	1	25.40	24.38	21.84	27.90	38.10	29.40
DTBM 10-8N	5/8	15.87	1/2	11.93	15/16	23.81	1	25.40	24.38	21.84	27.90	38.10	34.00
DTBM 10-12N	5/8	15.87	3/4	12.70	1-1/16	26.98	1	25.40	24.38	21.84	29.71	39.87	36.83
DTBM 12-8N	3/4	19.05	1/2	11.93	1-1/16	26.98	1-1/8	28.58	24.38	21.84	29.71	39.87	37.00
DTBM 12-12N	3/4	19.05	3/4	15.74	1-1/16	26.98	1-1/8	28.58	24.38	21.84	29.71	39.87	36.83
DTBM 14-12N	7/8	22.22	3/4	15.74	1-3/8	34.92	1-1/4	31.75	25.90	21.84	34.54	44.70	41.65
DTBM 16-12N	1	25.40	3/4	15.74	1-3/8	34.92	1-1/2	38.10	31.24	26.41	36.83	49.02	42.20
DTBM 16-16N	1	25.40	1	22.35	1-3/8	34.92	1-1/2	38.10	31.24	26.41	36.83	49.02	46.70
DTBM 20-20N	1-1/4	31.75	1-1/4	27.68	1-11/16	42.86	1-7/8	47.63	41.14	38.86	44.50	66.54	47.75
DTBM 24-24N	1-1/2	38.10	1-1/2	34.03	2	50.80	2-1/4	57.15	50.03	45.21	50.80	77.97	60.45
DTBM 32-32N	2	50.80	2	45.97	2-3/4	69.85	3	76.20	67.56	62.73	69.80	107.18	70.61

Connects fractional tube to female ISO tapered thread

Part No.	Tube O.D. D		T PT	E Min.	Width across flat				A	B	l	L	L1
	in	mm			h		H						
DTBM 6-4R	3/8	9.52	1/4	7.11	5/8	15.87	1/16	17.46	16.76	19.30	23.11	30.48	25.40
DTBM 8-6R	1/2	12.70	3/8	9.65	13/16	20.64	7/8	22.22	22.86	21.84	25.90	36.06	28.30
DTBM 8-8R	1/2	12.70	1/2	10.41	13/16	20.64	7/8	22.22	22.86	21.84	25.90	36.06	33.02
DTBM 10-8R	5/8	15.87	1/2	11.93	15/16	23.81	1	25.40	24.38	21.84	27.90	38.10	34.00

Male Branch Tee DTBM-N

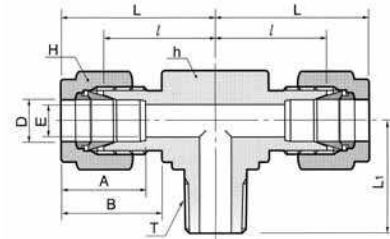

Connects metric tube to female NPT thread

Part No.	Tube O.D. D	T NPT	E Min.	Width across flat		A	B	l	L	L1
				h	H					
DTBM 3M-2N	3	1/8	2.4	12.7	12	12.9	15.3	17.0	23.6	17.8
DTBM 3M-4N	3	1/4	2.4	12.7	12	12.9	15.3	18.0	24.6	23.4
DTBM 4M-2N	4	1/8	2.4	12.7	12	13.7	16.1	18.8	25.4	18.8
DTBM 4M-4N	4	1/4	2.4	12.7	12	13.7	16.1	18.8	25.4	23.4
DTBM 6M-2N	6	1/8	4.8	12.7	14	15.3	17.7	19.6	27.0	18.8
DTBM 6M-4N	6	1/4	4.8	14.2	14	15.3	17.7	19.6	27.0	23.4
DTBM 6M-6N	6	3/8	4.8	17.5	14	15.3	17.7	22.4	29.8	26.2
DTBM 6M-8N	6	1/2	4.8	20.6	14	15.3	17.7	24.4	31.8	33.0
DTBM 8M-2N	8	1/8	4.8	14.3	16	16.2	18.6	21.3	28.8	19.8
DTBM 8M-4N	8	1/4	6.4	14.3	16	16.2	18.6	21.3	28.8	24.4
DTBM 8M-6N	8	3/8	6.4	17.5	16	16.2	18.6	23.1	30.6	26.2
DTBM 8M-8N	8	1/2	6.4	20.6	16	16.2	18.6	25.1	32.6	33.0
DTBM 10M-2N	10	1/8	4.8	17.5	19	17.2	19.5	23.9	31.5	23.6
DTBM 10M-4N	10	1/4	7.1	17.5	19	17.2	19.5	23.9	31.5	26.2
DTBM 10M-6N	10	3/8	7.9	17.5	19	17.2	19.5	23.9	31.5	26.2
DTBM 10M-8N	10	1/2	7.9	20.6	19	17.2	19.5	25.9	33.5	33.0
DTBM 12M-2N	12	1/8	4.8	20.6	22	22.8	22.0	25.9	36.0	23.6
DTBM 12M-4N	12	1/4	7.1	20.6	22	22.8	22.0	25.9	36.0	28.2
DTBM 12M-6N	12	3/8	9.5	20.6	22	22.8	22.0	25.9	36.0	28.2
DTBM 12M-8N	12	1/2	9.5	20.6	22	22.8	22.0	25.9	36.0	33.0
DTBM 12M-12N	12	3/4	9.5	27.0	22	22.8	22.0	29.7	39.8	36.8
DTBM 16M-6N	16	3/8	9.5	25.4	25	24.4	22.0	27.9	38.0	30.2
DTBM 16M-8N	16	1/2	11.9	25.4	25	24.4	22.0	27.9	38.0	35.1
DTBM 16M-12N	16	3/4	12.7	27.0	25	24.4	22.0	29.7	39.8	36.8
DTBM 18M-8N	18	1/2	11.9	27.0	30	24.4	22.0	29.7	39.8	36.8
DTBM 18M-12N	18	3/4	15.1	27.0	30	24.4	22.0	29.7	39.8	36.8
DTBM 20M-8N	20	1/2	11.9	34.92	32	26.0	22.0	34.5	44.6	41.7
DTBM 20M-12N	20	3/4	15.9	34.92	32	26.0	22.0	34.5	44.6	41.7
DTBM 22M-12N	22	3/4	15.9	34.92	32	26.0	22.0	34.5	44.6	41.7
DTBM 22M-16N	22	1	18.3	34.92	32	26.0	22.0	34.5	44.6	46.5
DTBM 25M-12N	25	3/4	15.9	34.92	38	31.3	26.5	36.8	49.1	41.7
DTBM 25M-16N	25	1	21.8	34.92	38	31.3	26.5	36.8	49.1	46.5

Male Branch Tee DTBM-R

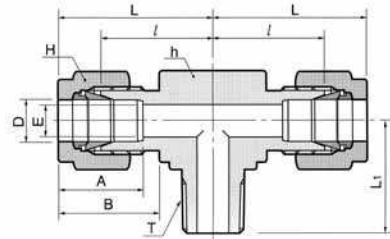

Connects metric tube to female ISO tapered thread

Part No.	Tube O.D. D	T PT	E Min.	Width across flat		A	B	l	L	L1
				h	H					
DTBM 3M-2R	3	1/8	2.4	12.7	12	12.9	15.3	17.0	23.6	17.8
DTBM 3M-4R	3	1/4	2.4	12.7	12	12.9	15.3	18.0	24.6	23.4
DTBM 4M-2R	4	1/8	2.4	12.7	12	13.7	16.1	18.8	25.4	18.8
DTBM 4M-4R	4	1/4	2.4	12.7	12	13.7	16.1	18.8	25.4	23.4
DTBM 6M-2R	6	1/8	4.8	12.7	14	15.3	17.7	19.6	27.0	18.8
DTBM 6M-4R	6	1/4	4.8	14.2	14	15.3	17.7	19.6	27.0	23.4
DTBM 6M-6R	6	3/8	4.8	17.5	14	15.3	17.7	22.4	29.8	26.2
DTBM 6M-8R	6	1/2	4.8	20.6	14	15.3	17.7	24.4	31.8	33.0
DTBM 8M-2R	8	1/8	4.8	14.3	16	16.2	18.6	21.3	28.8	19.8
DTBM 8M-4R	8	1/4	6.4	14.3	16	16.2	18.6	21.3	28.8	24.4
DTBM 8M-6R	8	3/8	6.4	17.5	16	16.2	18.6	23.1	30.6	26.2
DTBM 8M-8R	8	1/2	6.4	20.6	16	16.2	18.6	25.1	32.6	33.0
DTBM 10M-2R	10	1/8	4.8	17.5	19	17.2	19.5	23.9	31.5	23.6
DTBM 10M-4R	10	1/4	7.1	17.5	19	17.2	19.5	23.9	31.5	26.2
DTBM 10M-6R	10	3/8	7.9	17.5	19	17.2	19.5	23.9	31.5	26.2
DTBM 10M-8R	10	1/2	7.9	20.6	19	17.2	19.5	25.9	33.5	33.0
DTBM 12M-2R	12	1/8	4.8	20.6	22	22.8	22.0	25.9	36.0	23.6
DTBM 12M-4R	12	1/4	7.1	20.6	22	22.8	22.0	25.9	36.0	28.2
DTBM 12M-6R	12	3/8	9.5	20.6	22	22.8	22.0	25.9	36.0	28.2
DTBM 12M-8R	12	1/2	9.5	20.6	22	22.8	22.0	25.9	36.0	33.0
DTBM 12M-12R	12	3/4	9.5	27.0	22	22.8	22.0	29.7	39.8	36.8
DTBM 16M-6R	16	3/8	9.5	25.4	25	24.4	22.0	27.9	38.0	30.2
DTBM 16M-8R	16	1/2	11.9	25.4	25	24.4	22.0	27.9	38.0	35.1
DTBM 16M-12R	16	3/4	12.7	27.0	25	24.4	22.0	29.7	39.8	36.8
DTBM 18M-8R	18	1/2	11.9	27.0	30	24.4	22.0	29.7	39.8	36.8
DTBM 18M-12R	18	3/4	15.1	27.0	30	24.4	22.0	29.7	39.8	36.8
DTBM 20M-8R	20	1/2	11.9	34.92	32	26.0	22.0	34.5	44.6	41.7
DTBM 20M-12R	20	3/4	15.9	34.92	32	26.0	22.0	34.5	44.6	41.7
DTBM 22M-12R	22	3/4	15.9	34.92	32	26.0	22.0	34.5	44.6	41.7
DTBM 22M-16R	22	1	18.3	34.92	32	26.0	22.0	34.5	44.6	46.5
DTBM 25M-12R	25	3/4	15.9	34.92	38	31.3	26.5	36.8	49.1	41.7
DTBM 25M-16R	25	1	21.8	34.92	38	31.3	26.5	36.8	49.1	46.5

Dk-Lok Tube Fittings

Female Connector DCF-N

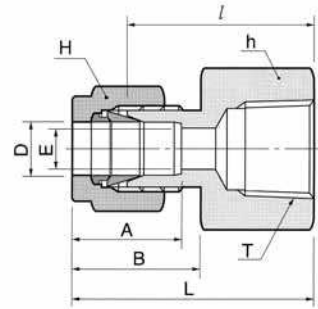
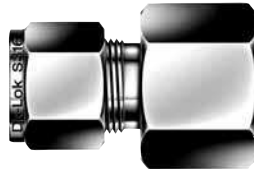

Connects fractional tube to male NPT thread

Part No.	Tube O.D. D		T NPT	E Min.	Width across flat				A	B	l	L
	in	mm			h	mm	H	mm				
DCF 1-1N	1/16	1.59	1/16	1.27	7/16	11.11	5/16	7.93	8.63	10.92	19.81	23.62
DCF 1-2N	1/16	1.59	1/8	1.27	9/16	14.28	5/16	7.93	8.63	10.92	20.57	24.38
DCF 2-2N	1/8	3.17	1/8	2.28	9/16	14.28	7/16	11.11	12.70	15.24	22.09	28.70
DCF 2-4N	1/8	3.17	1/4	2.28	3/4	19.05	7/16	11.11	12.70	15.24	26.92	33.52
DCF 3-2N	3/16	4.76	1/8	3.04	9/16	14.28	1/2	12.70	13.71	16.00	23.11	29.71
DCF 4-2N	1/4	6.35	1/8	4.82	9/16	14.28	9/16	14.28	15.24	17.78	23.87	31.24
DCF 4-4N	1/4	6.35	1/4	4.82	3/4	19.05	9/16	14.28	15.24	17.78	28.44	35.81
DCF 4-6N	1/4	6.35	3/8	4.82	7/8	22.22	9/16	14.28	15.24	17.78	30.22	37.59
DCF 4-8N	1/4	6.35	1/2	4.82	1-1/16	26.98	9/16	14.28	15.24	17.78	35.05	42.41
DCF 5-2N	5/16	7.93	1/8	6.35	9/16	14.28	5/8	15.87	16.25	18.54	24.63	32.00
DCF 5-4N	5/16	7.93	1/4	6.35	3/4	19.05	5/8	15.87	16.25	18.54	29.46	36.83
DCF 6-2N	3/8	9.52	1/8	7.11	5/8	15.87	11/16	17.46	16.76	19.30	25.40	32.76
DCF 6-4N	3/8	9.52	1/4	7.11	3/4	19.05	11/16	17.46	16.76	19.30	30.22	37.59
DCF 6-6N	3/8	9.52	3/8	7.11	7/8	22.22	11/16	17.46	16.76	19.30	31.75	39.11
DCF 6-8N	3/8	9.52	1/2	7.11	1-1/16	26.98	11/16	17.46	16.76	19.30	36.57	43.94
DCF 6-12N	3/8	9.52	3/4	7.11	1-5/16	33.33	11/16	17.46	16.76	19.30	40.38	47.75
DCF 8-4N	1/2	12.70	1/4	10.41	1-3/16	20.64	7/8	22.22	22.86	21.84	30.22	40.38
DCF 8-6N	1/2	12.70	3/8	10.41	7/8	22.22	7/8	22.22	22.86	21.84	31.75	41.91
DCF 8-8N	1/2	12.70	1/2	10.41	1-1/16	26.98	7/8	22.22	22.86	21.84	36.57	46.73
DCF 8-12N	1/2	12.70	3/4	10.41	1-5/16	33.33	7/8	22.22	22.86	21.84	38.10	48.26
DCF 10-6N	5/8	15.87	3/8	12.70	15/16	23.81	1	25.40	24.38	21.84	31.75	41.91
DCF 10-8N	5/8	15.87	1/2	12.70	1-1/16	26.98	1	25.40	24.38	21.84	36.57	46.73
DCF 10-12N	5/8	15.87	3/4	12.70	1-5/16	33.33	1	25.40	24.38	21.84	38.10	48.26
DCF 12-8N	3/4	19.05	1/2	15.74	1-1/16	26.98	1-1/8	28.58	24.38	21.84	36.57	46.73
DCF 12-12N	3/4	19.05	3/4	15.74	1-5/16	33.33	1-1/8	28.58	24.38	21.84	38.10	48.26
DCF 14-12N	7/8	22.22	3/4	18.28	1-5/16	33.33	1-1/4	31.75	25.90	21.84	39.62	49.78
DCF 16-12N	1	25.40	3/4	22.35	1-3/8	34.92	1-1/2	38.10	31.24	26.41	41.14	53.34
DCF 16-16N	1	25.40	1	22.35	1-5/8	41.27	1-1/2	38.10	31.24	26.41	50.03	62.23
DCF 20-20N	1-1/4	31.75	1-1/4	27.68	2-1/8	53.98	1-7/8	47.63	41.14	38.86	52.57	74.67
DCF 24-24N	1-1/2	38.10	1-1/2	34.03	2-3/8	60.33	2-1/4	57.15	50.03	45.21	56.13	83.31
DCF 32-32N	2	50.80	2	45.97	2-1/8	73.03	3	76.20	67.56	62.73	64.26	101.60

**Female Connector
DCF-N**

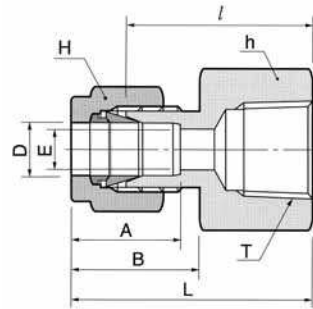
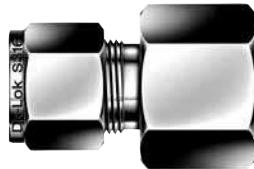

Connects metric tube to male NPT thread

Part No.	Tube O.D. D	T NPT	E Min.	Width across flat		A	B	l	L
				h	H				
DCF 3M-2N	3	1/8	2.4	14	12	12.9	15.3	22.1	28.7
DCF 3M-4N	3	1/4	2.4	19	12	12.9	15.3	26.9	33.5
DCF 4M-2N	4	1/8	2.4	14	12	13.7	16.1	23.1	29.7
DCF 6M-2N	6	1/8	4.8	14	14	15.3	17.7	23.9	31.3
DCF 6M-4N	6	1/4	4.8	19	14	15.3	17.7	28.4	35.8
DCF 6M-6N	6	3/8	4.8	22	14	15.3	17.7	29.5	36.9
DCF 6M-8N	6	1/2	4.8	27	14	15.3	17.7	35.1	42.5
DCF 8M-2N	8	1/8	6.4	15	16	16.2	18.6	24.6	32.1
DCF 8M-4N	8	1/4	6.4	19	16	16.2	18.6	29.5	37.0
DCF 8M-6N	8	3/8	6.4	22	16	16.2	18.6	30.2	37.7
DCF 8M-8N	8	1/2	6.4	27	16	16.2	18.6	35.8	43.3
DCF 10M-2N	10	1/8	7.9	18	19	17.2	19.5	25.4	33.0
DCF 10M-4N	10	1/4	7.9	19	19	17.2	19.5	30.2	37.8
DCF 10M-6N	10	3/8	7.9	22	19	17.2	19.5	31.0	38.6
DCF 10M-8N	10	1/2	7.9	27	19	17.2	19.5	36.6	44.2
DCF 12M-2N	12	1/8	8.3	22	22	22.8	22.0	28.4	38.5
DCF 12M-4N	12	1/4	9.5	22	22	22.8	22.0	30.2	40.3
DCF 12M-6N	12	3/8	9.5	22	22	22.8	22.0	31.0	41.1
DCF 12M-8N	12	1/2	9.5	27	22	22.8	22.0	36.6	46.7
DCF 12M-12N	12	3/4	9.5	35	22	22.8	22.0	38.9	49.0
DCF 15M-8N	15	1/2	11.9	27	25	24.4	22.0	36.6	46.7
DCF 16M-8N	16	1/2	12.7	27	25	24.4	22.0	36.8	46.9
DCF 20M-8N	20	1/2	15.9	30	32	26.0	22.0	37.8	47.9
DCF 20M-12N	20	3/4	15.9	35	32	26.0	22.0	39.6	49.7
DCF 22M-12N	22	3/4	18.3	35	32	26.0	22.0	39.6	49.7
DCF 22M-16N	22	1	18.3	41	32	26.0	22.0	47.8	57.9
DCF 25M-12N	25	3/4	21.8	35	38	31.3	26.5	41.1	53.4
DCF 25M-16N	25	1	21.8	41	38	31.3	26.5	50.0	62.3

Dk-Lok Tube Fittings

Female Connector DCF-R

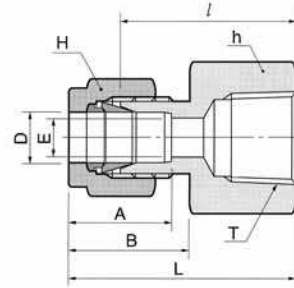
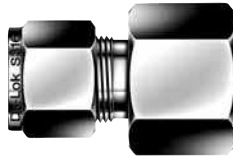

Connects fractional tube to male ISO tapered thread

Part No.	Tube O.D. D		T PT	E Min.	Width across flat				A	B	l	L
	in	mm			h	H	in	mm				
DCF 2-2R	1/8	3.17	1/8	2.28	9/16	14.28	7/16	11.11	12.70	15.24	22.09	28.70
DCF 4-2R	1/4	6.35	1/8	4.82	9/16	14.28	9/16	14.28	15.24	17.78	23.87	31.24
DCF 4-4R	1/4	6.35	1/4	4.82	3/4	19.05	9/16	14.28	15.24	17.78	28.44	35.81
DCF 4-6R	1/4	6.35	3/8	4.82	7/8	22.22	9/16	14.28	15.24	17.78	30.22	37.59
DCF 4-8R	1/4	6.35	1/2	4.82	1-1/16	26.98	9/16	14.28	15.24	17.78	35.05	42.41
DCF 6-4R	3/8	9.52	1/4	7.11	3/4	19.05	11/16	17.46	16.76	19.30	30.22	37.59
DCF 6-6R	3/8	9.52	3/8	7.11	7/8	22.22	11/16	17.46	16.76	19.30	31.75	39.11
DCF 6-8R	3/8	9.52	1/2	7.11	1-1/16	26.98	11/16	17.46	16.76	19.30	36.57	43.94
DCF 8-2R	1/2	12.70	1/8	10.41	13/16	20.64	7/8	22.22	22.86	21.84	25.40	35.56
DCF 8-4R	1/2	12.70	1/4	10.41	1-3/16	20.64	7/8	22.22	22.86	21.84	30.22	40.38
DCF 8-6R	1/2	12.70	3/8	10.41	7/8	22.22	7/8	22.22	22.86	21.84	31.75	41.91
DCF 8-8R	1/2	12.70	1/2	10.41	1-1/16	26.98	7/8	22.22	22.86	21.84	36.57	46.73
DCF 8-12R	1/2	12.70	3/4	10.41	1-5/16	33.33	7/8	22.22	22.86	21.84	38.10	48.26
DCF 10-6R	5/8	15.87	3/8	12.70	15/16	23.81	1	25.40	24.38	21.84	31.75	41.91
DCF 10-8R	5/8	15.87	1/2	12.70	1-1/16	26.98	1	25.40	24.38	21.84	36.57	46.73
DCF 10-12R	5/8	15.87	3/4	12.70	1-5/16	33.33	1	25.40	24.38	21.84	38.10	48.26
DCF 12-8R	3/4	19.05	1/2	15.74	1-1/16	26.98	1-1/8	28.58	24.38	21.84	36.57	46.73
DCF 12-12R	3/4	19.05	3/4	15.74	1-5/16	33.33	1-1/8	28.58	24.38	21.84	38.10	48.26
DCF 16-12R	1	25.40	3/4	22.35	1-3/8	34.92	1-1/2	38.10	31.24	26.41	41.14	53.34
DCF 16-16R	1	25.40	1	22.35	1-5/8	41.27	1-1/2	38.10	31.24	26.41	50.03	62.23
DCF 20-16R	1-1/4	31.75	1	27.68	1-3/4	44.45	1-7/8	47.63	41.14	38.86	52.57	74.67
DCF 20-20R	1-1/4	31.75	1-1/4	27.68	2-1/8	53.98	1-7/8	47.63	41.14	38.86	52.57	74.67
DCF 24-24R	1-1/2	38.10	1-1/2	34.03	2-3/8	60.33	2-1/4	57.15	50.03	45.21	56.13	83.81

Connects metric tube to male ISO tapered thread

Part No.	Tube O.D. D		T PT	E Min.	Width across flat		A	B	l	L
	in	mm			h	H				
DCF 3M-2R	3	3	1/8	2.4	14	12	12.9	15.3	22.1	28.7
DCF 3M-4R	3	3	1/4	2.4	19	12	12.9	15.3	26.9	33.5
DCF 4M-2R	4	4	1/8	2.4	14	12	13.7	16.1	23.1	29.7
DCF 6M-2R	6	6	1/8	4.8	14	14	15.3	17.7	23.9	31.3
DCF 6M-4R	6	6	1/4	4.8	19	14	15.3	17.7	28.4	35.8
DCF 6M-6R	6	6	3/8	4.8	22	14	15.3	17.7	29.5	36.9
DCF 6M-8R	6	6	1/2	4.8	27	14	15.3	17.7	35.1	42.5
DCF 8M-2R	8	8	1/8	6.4	15	16	16.2	18.6	24.6	32.1
DCF 8M-4R	8	8	1/4	6.4	19	16	16.2	18.6	29.5	37.0
DCF 8M-6R	8	8	3/8	6.4	22	16	16.2	18.6	30.2	37.7
DCF 8M-8R	8	8	1/2	6.4	27	16	16.2	18.6	35.8	43.3
DCF 10M-2R	10	10	1/8	7.9	18	19	17.2	19.5	25.4	33.0
DCF 10M-4R	10	10	1/4	7.9	19	19	17.2	19.5	30.2	37.8
DCF 10M-6R	10	10	3/8	7.9	22	19	17.2	19.5	31.0	38.6
DCF 10M-8R	10	10	1/2	7.9	27	19	17.2	19.5	36.6	44.2
DCF 12M-2R	12	12	1/8	8.3	22	22	22.8	22.0	28.4	38.5
DCF 12M-4R	12	12	1/4	9.5	22	22	22.8	22.0	30.2	40.3
DCF 12M-6R	12	12	3/8	9.5	22	22	22.8	22.0	31.0	41.1
DCF 12M-8R	12	12	1/2	9.5	27	22	22.8	22.0	36.6	46.7
DCF 12M-12R	12	12	3/4	9.5	35	22	22.8	22.0	38.9	49.0
DCF 15M-8R	15	15	1/2	11.9	27	25	24.4	22.0	36.6	46.7
DCF 16M-8R	16	16	1/2	12.7	27	25	24.4	22.0	36.8	46.9
DCF 20M-8R	20	20	1/2	15.9	30	32	26.0	22.0	37.8	47.9
DCF 20M-12R	20	20	3/4	15.9	35	32	26.0	22.0	39.6	49.7
DCF 22M-8R	22	22	1/2	18.3	30	32	26.0	22.0	38.0	48.1
DCF 22M-12R	22	22	3/4	18.3	35	32	26.0	22.0	39.6	49.7
DCF 22M-16R	22	22	1	18.3	41	32	26.0	22.0	47.8	57.9
DCF 25M-8R	25	25	1/2	21.8	35	38	31.3	26.5	41.1	53.4
DCF 25M-12R	25	25	3/4	21.8	35	38	31.3	26.5	41.1	53.4
DCF 25M-16R	25	25	1	21.8	41	38	31.3	26.5	50.0	62.3

Gauge Connector (Previously DCG)

DCF-GG

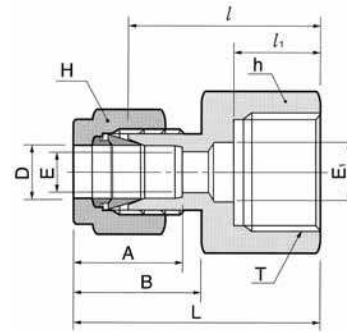
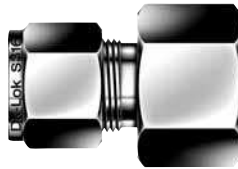

Connects fractional tube to Gauge (male ISO parallel thread)

Part No.	Tube O.D. D		T PF	E Min.	E ₁	Width across flat				A	B	l	l ₁	L
	in	mm				in	h	mm	in					
DCF 2-4GG	1/8	3.17	1/4	2.4	5.5	3/4	19.05	7/16	11.11	12.70	15.24	28.70	13.00	35.31
DCF 4-2GG	1/4	6.35	1/8	4.82	-	9/16	14.28	9/16	14.28	15.24	17.78	26.30	12.00	33.55
DCF 4-4GG	1/4	6.35	1/4	4.82	5.5	3/4	19.05	9/16	14.28	15.24	17.78	30.22	13.00	37.59
DCF 4-6GG	1/4	6.35	3/8	4.82	6.5	15/16	23.81	9/16	14.28	15.24	17.78	30.22	14.22	37.59
DCF 4-8GG	1/4	6.35	1/2	4.82	7.0	1-1/16	26.98	9/16	14.28	15.24	17.78	30.07	18.80	43.43
DCF 5-4GG	5/16	7.93	1/4	5.58	5.5	3/4	19.05	5/8	15.87	16.25	18.54	30.98	13.00	38.35
DCF 5-8GG	5/16	7.93	1/2	7.11	7.0	1-1/16	26.98	5/8	15.87	16.25	18.54	33.02	18.80	40.38
DCF 6-4GG	3/8	9.52	1/4	5.58	5.5	3/4	19.05	11/16	17.46	16.76	19.30	31.75	12.95	39.12
DCF 6-6GG	3/8	9.52	3/8	6.60	6.5	15/16	23.81	11/16	17.46	16.76	19.30	31.24	14.22	38.61
DCF 6-8GG	3/8	9.52	1/2	7.11	7.0	1-1/16	26.98	11/16	17.46	16.76	19.30	34.54	18.80	41.91
DCF 8-4GG	1/2	12.70	1/4	5.50	5.5	7/8	22.22	7/8	22.22	22.86	21.84	31.80	13.00	41.95
DCF 8-6GG	1/2	12.70	3/8	6.60	6.5	15/16	23.81	7/8	22.22	22.86	21.84	34.29	14.24	44.45
DCF 8-8GG	1/2	12.70	1/2	7.11	7.0	1-1/16	26.98	7/8	22.22	22.86	21.84	38.10	18.80	48.26

Connects metric tube to Gauge (male ISO parallel thread)

Part No.	Tube O.D. D	T PF	E Min.	E ₁	Width across flat		A	B	l	l ₁	L
	mm				h	H					
DCF 3M-4GG	3	1/4	2.4	5.5	19	12	12.9	15.3	28.7	13	35.3
DCF 6M-4GG	6	1/4	4.8	5.5	19	14	15.3	17.7	30.2	13	37.6
DCF 6M-6GG	6	3/8	4.8	6.5	24	14	15.3	17.7	30.2	14	37.6
DCF 6M-8GG	6	1/2	4.8	7.0	27	14	15.3	17.7	36.3	19	43.0
DCF 8M-4GG	8	1/4	5.5	5.5	19	16	16.2	18.6	31.0	13	38.5
DCF 8M-6GG	8	3/8	6.5	6.5	24	16	16.2	18.6	28.7	14	36.2
DCF 8M-8GG	8	1/2	7.0	7.0	27	16	16.2	18.6	33.0	19	40.5
DCF 10M-4GG	10	1/4	5.5	5.5	19	19	17.2	19.5	31.8	13	39.4
DCF 10M-6GG	10	3/8	6.5	6.5	24	19	17.2	19.5	31.2	14	38.8
DCF 10M-8GG	10	1/2	7.0	7.0	27	19	17.2	19.5	33.8	19	41.4
DCF 12M-4GG	12	1/4	5.5	5.5	22	22	22.8	22.0	31.8	13	41.9
DCF 12M-6GG	12	3/8	6.5	6.5	24	22	22.8	22.0	34.3	14	44.4
DCF 12M-8GG	12	1/2	7.0	7.0	27	22	22.8	22.0	38.1	19	48.2
DCF 20M-8GG	20	1/2	7.0	7.0	30	32	26.0	22.0	44.2	19	54.3
DCF 22M-8GG	22	1/2	7.0	7.0	30	32	26.0	22.0	44.2	19	54.3

Dk-Lok Tube Fittings

Bulkhead Female Connector DCBF-N

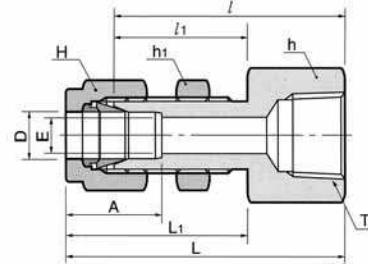
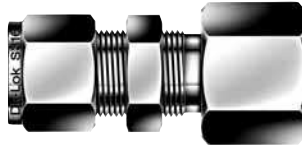

Connects fractional tube to male NPT thread

Part No.	Tube O.D. D		T NPT	E Min.	Width across flat			A	l	l ₁	L	L ₁	Panel Hole Drill Size	Panel Max Thickness			
	in	mm			h	h ₁	H										
DCBF 2-2N	1/8	3.17	1/8	2.28	9/16	14.28	1/2	12.70	7/16	11.11	12.70	38.10	24.63	44.70	31.24	8.33	12.70
DCBF 4-2N	1/4	6.35	1/8	4.82	5/8	15.87	5/8	15.87	9/16	14.28	15.24	39.62	26.16	46.99	33.52	11.50	10.16
DCBF 4-4N	1/4	6.35	1/4	4.82	3/4	19.05	5/8	15.87	9/16	14.28	15.24	44.45	26.16	51.81	33.52	11.50	10.16
DCBF 6-4N	3/8	9.52	1/4	7.11	3/4	19.05	3/4	19.05	11/16	17.46	16.76	47.75	29.46	55.11	36.83	14.68	11.17
DCBF 6-6N	3/8	9.52	3/8	7.11	7/8	22.22	3/4	19.05	11/16	17.46	16.76	49.41	29.46	56.77	36.83	14.68	11.17
DCBF 8-6N	1/2	12.70	3/8	10.41	15/16	23.81	15/16	23.81	7/8	22.22	22.86	51.56	31.75	61.72	41.91	19.44	12.70
DCBF 8-8N	1/2	12.70	1/2	10.41	1-1/16	26.98	15/16	23.81	7/8	22.22	22.86	56.38	31.75	66.54	41.91	19.44	12.70
DCBF 12-12N	3/4	19.05	3/4	15.74	1-1/4	31.75	1-3/16	30.16	1-1/8	28.57	24.38	63.60	38.30	73.51	47.21	25.79	16.76
DCBF 16-16N	1	25.40	1	22.35	1-5/8	41.27	1-5/8	41.27	1-1/2	38.10	31.24	81.04	45.21	93.23	57.40	33.73	19.05
DCBF 20-20N	1-1/4	31.75	1-1/4	27.68	1-7/8	47.63	1-7/8	47.63	1-7/8	47.63	41.14	83.49	47.75	105.59	69.85	41.67	19.05
DCBF 24-24N	1-1/2	38.10	1-1/2	34.03	1-1/4	57.15	2-1/4	57.15	2-1/4	57.15	50.03	87.39	49.27	114.57	76.45	49.61	19.05
DCBF 32-32N	2	50.80	2	45.97	1-3/4	69.85	2-3/4	69.85	3	76.20	67.56	95.30	56.38	132.63	93.71	57.94	19.05

Connects metric tube to male NPT thread

Part No.	Tube O.D. D		T NPT	E Min.	Width across flat			A	l	l ₁	L	L ₁	Panel Hole Drill Size	Panel Max Thickness
	in	mm			h	h ₁	H							
DCBF 6M-2M	6	6	1/8	4.8	15.8	15.8	14	15.3	39.6	26.2	46.90	35.00	11.5	10.2
DCBF 6M-4M	6	6	1/4	4.8	19.0	16.0	14	15.3	44.4	26.2	51.80	33.60	11.5	10.2
DCBF 8M-4M	8	8	1/4	6.3	19.0	17.4	16	16.2	46.7	28.6	53.85	35.55	13.1	11.2
DCBF 12M-8M	12	12	1/2	9.5	27.0	24.0	22	22.8	56.4	31.8	66.50	41.90	19.5	12.7

Female Elbow DLF-N

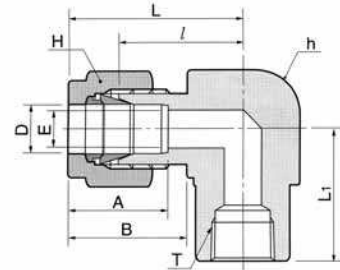

Connects fractional tube to male NPT thread

Part No.	Tube O.D.		T NPT	E Min.	Width across flat				A	B	l	L	L ₁
	D				h	H	A	B					
	in	mm											
DLF 2-2N	1/8	3.17	1/8	2.28	1/2	12.70	7/16	11.11	12.70	15.24	18.03	24.63	19.05
DLF 2-4N	1/8	3.17	1/4	2.28	11/16	17.46	7/16	11.11	12.70	15.24	20.82	27.43	22.35
DLF 3-2N	3/16	4.76	1/8	3.04	1/2	12.70	1/2	12.70	13.71	16.00	18.79	25.40	19.05
DLF 4-2N	1/4	6.35	1/8	4.82	1/2	12.70	9/16	14.28	15.24	17.78	19.55	26.92	19.05
DLF 4-4N	1/4	6.35	1/4	4.82	11/16	17.46	9/16	14.28	15.24	17.78	22.35	29.71	22.35
DLF 4-6N	1/4	6.35	3/8	4.82	13/16	20.64	9/16	14.28	15.24	17.78	24.38	31.75	22.35
DLF 4-8N	1/4	6.35	1/2	4.82	1	25.40	9/16	14.28	15.24	17.78	27.17	34.54	28.44
DLF 5-2N	5/16	7.93	1/8	6.35	9/16	14.28	5/8	15.87	16.25	18.54	21.33	28.70	19.05
DLF 5-4N	5/16	7.93	1/4	6.35	11/16	17.46	5/8	15.87	16.25	18.54	23.11	30.48	22.35
DLF 6-2N	3/8	9.52	1/8	7.11	5/8	15.87	11/16	17.46	16.76	19.30	23.11	30.48	19.05
DLF 6-4N	3/8	9.52	1/4	7.11	11/16	17.46	11/16	17.46	16.76	19.30	23.87	31.24	22.35
DLF 6-6N	3/8	9.52	3/8	7.11	13/16	20.64	11/16	17.46	16.76	19.30	25.90	33.27	22.35
DLF 6-8N	3/8	9.52	1/2	7.11	1	25.40	11/16	17.46	16.76	19.30	28.70	36.06	28.44
DLF 8-4N	1/2	12.70	1/4	10.41	13/16	20.64	7/8	22.22	22.86	21.84	25.90	36.06	22.35
DLF 8-6N	1/2	12.70	3/8	10.41	13/16	20.64	7/8	22.22	22.86	21.84	25.90	36.06	22.35
DLF 8-8N	1/2	12.70	1/2	10.41	1	25.40	7/8	22.22	22.86	21.84	28.70	38.86	28.44
DLF 10-6N	5/8	15.87	3/8	12.70	15/16	23.81	1	25.40	24.38	21.84	27.94	38.10	22.35
DLF 10-8N	5/8	15.87	1/2	12.70	1	25.40	1	25.40	24.38	21.84	29.71	39.87	28.44
DLF 12-8N	3/4	19.05	1/2	15.74	1-1/16	26.98	1-1/8	28.58	24.38	21.84	29.71	39.87	28.44
DLF 12-12N	3/4	19.05	3/4	15.74	1-3/8	34.92	1-1/8	28.58	24.38	21.84	34.54	44.70	31.75
DLF 14-12N	7/8	22.22	3/4	18.28	1-3/8	34.92	1-1/4	31.75	25.90	21.84	34.54	44.70	31.75
DLF 16-12N	1	25.40	3/4	22.35	1-3/8	34.92	1-1/2	38.10	31.24	26.41	36.83	49.02	31.75
DLF 16-16N	1	25.40	1	22.35	1-11/16	42.86	1-1/2	38.10	31.24	26.41	41.40	50.29	38.10

Connects metric tube to male NPT thread

Part No.	Tube O.D.		T NPT	E Min.	Width across flat		A	B	l	L	L ₁
	D				h	H					
	in	mm									
DLF 6M-2N	6	15.87	1/8	4.8	12.70	14	15.3	17.7	19.6	27.0	19.00
DLF 6M-4N	6	15.87	1/4	4.8	17.46	14	15.3	17.7	22.4	29.8	22.40
DLF 6M-6N	6	15.87	3/8	4.8	20.64	14	15.3	17.7	24.4	31.7	22.40
DLF 6M-8N	6	15.87	1/2	4.8	25.40	14	15.3	17.7	27.2	34.6	28.40
DLF 8M-2N	8	20.64	1/8	6.4	15.87	16	16.2	18.6	23.1	29.9	19.00
DLF 8M-4N	8	20.64	1/4	6.4	17.46	16	16.2	18.6	23.1	30.6	22.40
DLF 8M-8N	8	20.64	1/2	6.4	25.40	16	16.2	18.6	28.0	35.2	28.40
DLF 10M-2N	10	25.40	1/8	7.9	17.46	19	17.2	19.5	23.9	31.5	19.00
DLF 10M-4N	10	25.40	1/4	7.9	17.46	19	17.2	19.5	25.9	33.5	22.35
DLF 10M-6N	10	25.40	3/8	7.9	20.64	19	17.2	19.5	25.9	33.5	22.40
DLF 10M-8N	10	25.40	1/2	7.9	25.40	19	17.2	19.5	28.7	36.1	28.40
DLF 12M-4N	12	30.48	1/4	9.5	20.64	22	22.8	22.0	25.9	36.0	22.40
DLF 12M-6N	12	30.48	3/8	9.5	20.64	22	22.8	22.0	25.9	36.2	22.35
DLF 12M-8N	12	30.48	1/2	9.5	25.40	22	22.8	22.0	28.7	38.8	28.40
DLF 16M-8N	16	40.64	1/2	12.7	26.98	25	24.4	22.0	29.7	39.5	28.40

Dk-Lok Tube Fittings

Female Run Tee DTRF-N

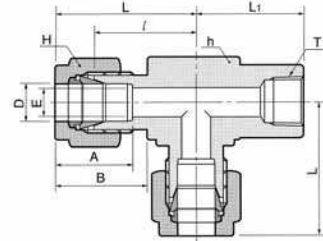

Connects fractional tube to male NPT thread

Part No.	Tube O.D.		T NPT	E Min.	Width across flat				A	B	l	L	L ₁
	D				h		H						
	in	mm			in	mm	in	mm					
DTRF 2-2N	1/8	3.17	1/8	2.28	1/2	12.70	7/16	11.11	12.70	15.24	18.03	24.63	19.05
DTRF 2-4N	1/8	3.17	1/4	2.28	11/16	17.46	7/16	11.11	12.70	15.24	20.82	27.43	22.35
DTRF 3-2N	3/16	4.76	1/8	3.04	1/2	12.70	1/2	12.70	13.71	16.00	18.79	25.40	19.05
DTRF 4-2N	1/4	6.35	1/8	4.82	1/2	12.70	9/16	14.28	15.24	17.78	19.55	26.92	19.05
DTRF 4-4N	1/4	6.35	1/4	4.82	11/16	17.46	9/16	14.28	15.24	17.78	22.86	29.71	22.35
DTRF 4-6N	1/4	6.35	3/8	4.82	13/16	20.64	9/16	14.28	15.24	17.78	24.38	31.75	22.35
DTRF 4-8N	1/4	6.35	1/2	4.82	1	25.40	9/16	14.28	15.24	17.78	27.17	34.54	28.44
DTRF 5-2N	5/16	7.94	1/8	6.35	9/16	14.28	5/8	15.87	16.25	18.54	21.33	28.70	19.05
DTRF 5-4N	5/16	7.94	1/4	6.35	11/16	17.46	5/8	15.87	16.25	18.54	23.11	30.48	22.35
DTRF 6-2N	3/8	9.52	1/8	7.11	5/8	15.87	11/16	17.46	16.76	19.30	23.11	30.48	19.05
DTRF 6-4N	3/8	9.52	1/4	7.11	11/16	17.46	11/16	17.46	16.76	19.30	23.87	31.24	22.35
DTRF 6-6N	3/8	9.52	3/8	6.35	13/16	20.64	11/16	17.46	16.76	19.30	25.90	33.27	22.35
DTRF 6-8N	3/8	9.52	1/2	7.11	1	25.40	11/16	17.46	16.76	19.30	28.70	36.06	28.44
DTRF 8-4N	1/2	12.70	1/4	10.41	13/16	20.64	7/8	22.22	22.86	21.84	25.90	36.06	22.35
DTRF 8-6N	1/2	12.70	3/8	10.41	13/16	20.64	7/8	22.22	22.86	21.84	25.90	36.06	22.35
DTRF 8-8N	1/2	12.70	1/2	10.41	1	25.40	7/8	22.22	22.86	21.84	29.71	39.87	28.44
DTRF 10-6N	5/8	15.87	3/8	12.70	15/16	23.81	1	25.40	24.38	21.84	27.94	38.10	22.35
DTRF 10-8N	5/8	15.87	1/2	12.70	1	25.40	1	25.40	24.38	21.84	28.70	38.86	28.44
DTRF 12-8N	3/4	19.05	1/2	15.74	1-1/16	26.98	1-1/8	28.58	24.38	21.84	29.71	39.87	28.44
DTRF 12-12N	3/4	19.05	3/4	15.74	1-3/8	34.92	1-1/8	28.58	24.38	21.84	34.54	44.70	31.75
DTRF 14-12N	7/8	22.22	3/4	18.28	1-3/8	34.92	1-1/4	31.75	31.75	21.84	34.54	44.70	31.75
DTRF 16-12N	1	25.40	3/4	22.35	1-3/8	34.92	1-1/2	38.10	38.10	26.41	36.83	49.02	31.75
DTRF 16-16N	1	25.40	1	22.35	1-1/16	42.86	1-1/2	38.10	38.10	26.41	41.40	50.29	38.10

Connects metric tube to male NPT thread

Part No.	Tube O.D.		T NPT	E Min.	Width across flat		A	B	l	L	L ₁
	D				h						
DTRF 6M-2N	6		1/8	4.8	12.70	14	15.3	17.7	19.6	27.0	19.00
DTRF 6M-4N	6		1/4	4.8	17.46	14	15.3	17.7	22.4	29.8	22.40
DTRF 6M-6N	6		3/8	4.8	20.64	14	15.3	17.7	24.4	31.7	22.40
DTRF 6M-8N	6		1/2	4.8	25.40	14	15.3	17.7	27.2	34.5	28.40
DTRF 8M-2N	8		1/8	6.4	15.87	16	16.2	18.6	23.1	29.9	19.00
DTRF 8M-4N	8		1/4	6.4	17.46	16	16.2	18.6	23.1	30.6	22.40
DTRF 8M-6N	8		3/8	6.4	20.64	16	16.2	18.6	25.2	32.4	22.40
DTRF 8M-8N	8		1/2	6.4	25.40	16	16.2	18.6	28.0	35.2	28.40
DTRF 10M-2N	10		1/8	7.9	20.64	19	17.2	19.5	23.9	31.5	19.00
DTRF 10M-4N	10		1/4	7.9	20.64	19	17.2	19.5	25.9	33.6	22.40
DTRF 10M-6N	10		3/8	7.9	20.64	19	17.2	19.5	25.9	33.6	22.40
DTRF 10M-8N	10		1/2	7.9	25.40	19	17.2	19.5	26.2	33.6	28.40
DTRF 12M-4N	12		1/4	9.5	20.64	22	22.8	22.0	25.9	36.0	22.40
DTRF 12M-6N	12		3/8	9.5	20.64	22	22.8	22.0	25.9	36.0	22.40
DTRF 12M-8N	12		1/2	9.5	25.40	22	22.8	22.0	29.7	40.0	28.40
DTRF 16M-8N	16		1/2	12.7	25.40	25	24.4	22.0	29.7	40.0	28.40

Female Branch Tee DTBF-N

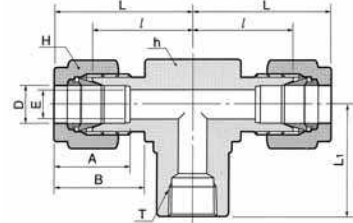

Connects fractional tube to male NPT thread

Part No.	Tube O.D.		T NPT	E Min.	Width across flat				A	B	l	L	L ₁
	D in	mm			h	H	in	mm					
DTBF 2-2N	1/8	3.17	1/8	2.28	1/2	12.70	7/16	11.11	12.70	15.24	18.03	24.38	19.05
DTBF 2-4N	1/8	3.17	1/4	2.28	11/16	17.46	7/16	11.11	12.70	15.24	20.82	27.43	22.35
DTBF 3-2N	3/16	4.76	1/8	3.04	1/2	12.70	1/2	12.70	13.71	16.00	18.79	25.40	19.05
DTBF 4-2N	1/4	6.35	1/8	4.82	1/2	12.70	9/16	14.28	15.24	17.78	19.55	26.92	19.05
DTBF 4-4N	1/4	6.35	1/4	4.82	11/16	17.46	9/16	14.28	15.24	17.78	22.35	29.71	22.35
DTBF 4-6N	1/4	6.35	3/8	4.82	13/16	20.64	9/16	14.28	15.24	17.78	24.38	31.75	22.35
DTBF 4-8N	1/4	6.35	1/2	4.82	1	25.40	9/16	14.28	15.24	17.78	27.17	34.54	28.44
DTBF 5-2N	5/16	7.94	1/8	6.35	9/16	14.28	5/8	15.87	16.25	18.54	21.33	28.70	19.05
DTBF 5-4N	5/16	7.94	1/4	6.35	11/16	17.46	5/8	15.87	16.25	18.54	23.11	30.48	22.35
DTBF 6-2N	3/8	9.52	1/8	7.11	5/8	15.87	11/16	17.46	16.76	19.30	23.11	30.48	19.05
DTBF 6-4N	3/8	9.52	1/4	7.11	11/16	17.46	11/16	17.46	16.76	19.30	23.87	31.24	22.35
DTBF 6-6N	3/8	9.52	3/8	6.35	13/16	20.64	11/16	17.46	16.76	19.30	25.90	33.27	22.35
DTBF 6-8N	3/8	9.52	1/2	7.11	1	25.40	11/16	17.46	16.76	19.30	28.70	36.06	28.44
DTBF 8-4N	1/2	12.70	1/4	10.41	13/16	20.64	7/8	22.22	22.86	21.84	25.90	36.06	22.35
DTBF 8-6N	1/2	12.70	3/8	10.41	13/16	20.64	7/8	22.22	22.86	21.84	25.90	36.06	22.35
DTBF 8-8N	1/2	12.70	1/2	10.41	1	25.40	7/8	22.22	22.86	21.84	29.71	39.87	28.44
DTBF 10-6N	5/8	15.87	3/8	12.70	15/16	23.81	1	25.40	24.38	21.84	27.94	38.10	22.35
DTBF 10-8N	5/8	15.87	1/2	12.70	1	25.40	1	25.40	24.38	21.84	28.70	38.86	28.44
DTBF 12-8N	3/4	19.05	1/2	15.74	1-1/16	26.98	1-1/8	28.58	24.38	21.84	29.71	39.87	28.44
DTBF 12-12N	3/4	19.05	3/4	15.74	1-3/8	34.92	1-1/8	28.58	24.38	21.84	34.54	44.70	31.75
DTBF 14-12N	7/8	22.22	3/4	18.28	1-3/8	34.92	1-1/4	31.75	25.90	21.84	34.54	44.70	31.75
DTBF 16-12N	1	25.40	3/4	22.35	1-3/8	34.92	1-1/2	38.10	31.24	26.41	36.83	49.02	31.75
DTBF 16-16N	1	25.40	1	22.35	1-11/16	42.86	1-1/2	38.10	31.24	26.41	41.40	53.59	38.10

Connects metric tube to male NPT thread

Part No.	Tube O.D.		T NPT	E Min.	Width across flat		A	B	l	L	L ₁
	D	mm			h	H					
DTBF 6M-2N	6		1/8	4.8	12.70	14	15.3	17.7	19.6	27.0	19.00
DTBF 6M-4N	6		1/4	4.8	17.46	14	15.3	17.7	22.4	29.8	22.40
DTBF 6M-6N	6		3/8	4.8	20.64	14	15.3	17.7	24.4	31.7	22.40
DTBF 6M-8N	6		1/2	4.8	25.40	14	15.3	17.7	27.2	34.5	28.40
DTBF 8M-2N	8		1/8	6.4	15.87	16	16.2	18.6	23.1	29.9	19.00
DTBF 8M-4N	8		1/4	6.4	17.46	16	16.2	18.6	23.1	30.6	22.40
DTBF 8M-6N	8		3/8	6.4	20.64	16	16.2	18.6	25.2	32.4	22.40
DTBF 8M-8N	8		1/2	6.4	25.40	16	16.2	18.6	28.0	35.2	28.40
DTBF 10M-2N	10		1/8	7.9	17.50	19	17.2	19.5	23.9	31.5	19.00
DTBF 10M-4N	10		1/4	7.9	20.64	19	17.2	19.5	25.9	33.5	22.40
DTBF 10M-6N	10		3/8	7.9	20.64	19	17.2	19.5	25.9	33.5	22.40
DTBF 10M-8N	10		1/2	9.5	25.40	19	17.2	19.5	26.2	33.6	22.40
DTBF 12M-4N	12		1/4	9.5	20.64	22	22.8	22.0	25.9	36.0	22.40
DTBF 12M-6N	12		3/8	9.5	20.64	22	22.8	22.0	25.9	36.0	22.40
DTBF 12M-8N	12		1/2	9.5	25.40	22	22.8	22.0	29.7	40.0	28.40
DTBF 16M-8N	16		1/2	12.7	25.40	25	24.4	22.0	29.7	40.0	28.70

Dk-Lok Tube Fittings

Reducer DR

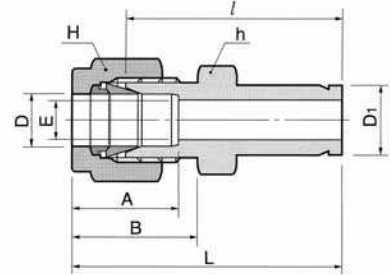
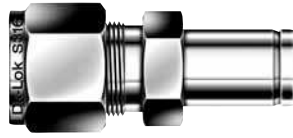

Connects fractional tube to fractional Dk-Lok port

Part No.	Tube O.D.				E Min.	Width across flat				A	B	l	L
	D		D ₁			h		H					
	in	mm	in	mm		in	mm	in	mm				
DR 1-2	1/16	1.59	1/8	3.17	1.27	5/16	7.93	5/16	7.93	8.63	10.92	25.40	29.21
DR 1-4	1/16	1.59	1/4	6.35	1.27	5/16	7.93	5/16	7.93	8.63	10.92	27.68	31.49
DR 2-1	1/8	3.17	1/16	1.59	1.76	7/16	11.11	7/16	11.11	12.70	15.24	22.35	28.95
DR 2-2	1/8	3.17	1/8	3.17	2.03	7/16	11.11	7/16	11.11	12.70	15.24	26.92	33.52
DR 2-3	1/8	3.17	3/16	4.76	2.28	7/16	11.11	7/16	11.11	12.70	15.24	27.68	34.29
DR 2-4	1/8	3.17	1/4	6.35	2.28	7/16	11.11	7/16	11.11	12.70	15.24	29.46	36.06
DR 2-6	1/8	3.17	3/8	9.52	2.28	7/16	11.11	7/16	11.11	12.70	15.24	30.98	37.59
DR 2-8	1/8	3.17	1/2	12.70	2.28	9/16	14.28	7/16	11.11	12.70	15.24	37.59	44.19
DR 3-2	3/16	4.76	1/8	3.17	2.03	7/16	11.11	1/2	12.70	13.71	16.00	28.19	34.79
DR 3-4	3/16	4.76	1/4	6.35	3.04	7/16	11.11	1/2	12.70	13.71	16.00	30.48	37.08
DR 4-2	1/4	6.35	1/8	3.17	2.03	1/2	12.70	9/16	14.28	15.24	17.78	29.46	36.83
DR 4-3	1/4	6.35	3/16	4.76	3.04	1/2	12.70	9/16	14.28	15.24	17.78	30.22	37.59
DR 4-4	1/4	6.35	1/4	6.35	4.82	1/2	12.70	9/16	14.28	15.24	17.78	31.75	39.11
DR 4-5	1/4	6.35	5/16	7.93	4.82	1/2	12.70	9/16	14.28	15.24	17.78	32.51	39.87
DR 4-6	1/4	6.35	3/8	9.52	4.82	1/2	12.70	9/16	14.28	15.24	17.78	33.27	40.64
DR 4-8	1/4	6.35	1/2	12.70	4.82	9/16	14.28	9/16	14.28	15.24	17.78	38.86	46.22
DR 4-10	1/4	6.35	5/8	15.87	4.82	11/16	17.46	9/16	14.28	15.24	17.78	40.64	48.00
DR 4-12	1/4	6.35	3/4	19.05	4.82	13/16	20.64	9/16	14.28	15.24	17.78	40.38	47.75
DR 5-6	5/16	7.93	3/8	9.52	6.35	9/16	14.28	5/8	15.87	16.25	18.54	34.54	41.91
DR 5-8	5/16	7.93	1/2	12.70	6.35	9/16	14.28	5/8	15.87	16.25	18.54	40.13	47.49
DR 6-4	3/8	9.52	1/4	6.35	4.82	5/8	15.87	11/16	17.46	16.76	19.30	34.03	41.40
DR 6-6	3/8	9.52	3/8	9.52	7.11	5/8	15.87	11/16	17.46	16.76	19.30	35.81	43.18
DR 6-8	3/8	9.52	1/2	12.70	7.11	5/8	15.87	11/16	17.46	16.76	19.30	41.14	48.51
DR 6-10	3/8	9.52	5/8	15.87	7.11	11/16	17.46	11/16	17.46	16.76	19.30	42.92	50.29
DR 6-12	3/8	9.52	3/4	19.05	7.11	13/16	20.64	11/16	17.46	16.76	19.30	42.92	50.29
DR 8-4	1/2	12.70	1/4	6.35	4.82	13/16	20.64	7/8	22.22	22.86	21.84	34.79	44.95
DR 8-6	1/2	12.70	3/8	9.52	7.11	13/16	20.64	7/8	22.22	22.86	21.84	36.57	46.73
DR 8-8	1/2	12.70	1/2	12.70	9.90	13/16	20.64	7/8	22.22	22.86	21.84	42.16	52.32
DR 8-10	1/2	12.70	5/8	15.87	10.41	13/16	20.64	7/8	22.22	22.86	21.84	43.68	53.84
DR 8-12	1/2	12.70	3/4	19.05	10.41	13/16	20.64	7/8	22.22	22.86	21.84	43.68	53.84
DR 8-16	1/2	12.70	1	25.40	10.41	1-1/16	26.98	7/8	22.22	22.86	21.84	50.03	60.19
DR10-12	5/8	15.87	3/4	19.05	12.70	15/16	23.81	1	25.40	24.38	21.84	44.45	54.61
DR10-14	5/8	15.87	7/8	22.22	12.70	15/16	23.81	1	25.40	24.38	21.84	45.97	56.13
DR10-16	5/8	15.87	1	25.40	12.70	1-1/16	26.98	1	25.40	24.38	21.84	50.80	60.96
DR12-8	3/4	19.05	1/2	12.70	9.90	1-1/16	26.98	1-1/8	28.57	24.38	21.84	44.45	54.61
DR12-16	3/4	19.05	1	25.40	15.74	1-1/16	26.98	1-1/8	28.57	24.38	21.84	52.32	62.48
DR16-20	1	25.40	1-1/4	31.75	22.35	1-3/8	34.93	1-1/2	38.10	31.24	26.41	68.32	80.51
DR16-24	1	25.40	1-1/2	38.10	22.35	1-5/8	41.28	1-1/2	38.10	31.24	26.41	76.96	89.15
DR16-32	1	25.40	2	50.80	22.35	2-1/8	53.98	1-1/2	38.10	31.24	26.41	100.33	112.52
DR20-24	1-1/4	31.75	1-1/2	38.10	27.68	1-7/8	47.63	1-7/8	57.15	41.14	38.86	82.04	104.14
DR20-32	1-1/4	31.75	2	50.80	27.68	1-7/8	47.63	1-7/8	76.20	41.14	38.86	103.12	125.22
DR24-32	1-1/2	38.10	2	50.80	34.03	2-1/4	57.15	2-1/4	76.20	50.03	45.21	104.14	131.31

Reducer DR

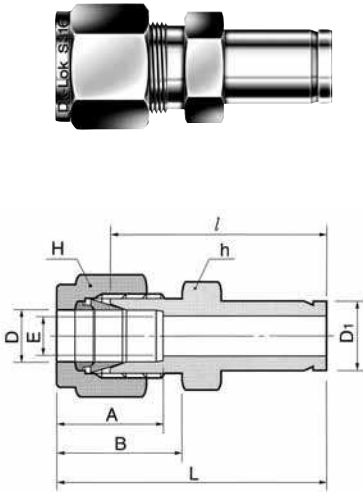

Connects metric tube to fractional Dk-Lok port

Part No.	Tube O.D.		E Min.	Width across flat		A	B	l	L
	D	D ₁ in mm		h	H				
DR 2M-2	2	1/8 3.17	1.7	12	12	12.9	15.3	26.9	33.5
DR 3M-2	3	1/8 3.17	2.0	12	12	12.9	15.3	26.9	33.5
DR 3M-4	3	1/4 6.35	2.4	12	12	12.9	15.3	29.5	36.1
DR 4M-4	4	1/4 6.35	2.4	12	12	13.7	16.1	30.5	37.1
DR 6M-2	6	1/8 3.18	2.0	14	14	15.3	17.7	29.5	36.9
DR 6M-4	6	1/4 6.35	4.8	14	14	15.3	17.7	31.8	39.2
DR 6M-5	6	5/16 7.93	4.8	14	14	15.3	17.7	32.5	39.9
DR 6M-6	6	3/8 9.52	4.8	14	14	15.3	17.7	33.3	40.7
DR 6M-8	6	1/2 12.70	4.8	14	14	15.3	17.7	38.9	46.3
DR 8M-6	8	3/8 9.52	6.4	15	16	16.2	18.6	34.5	42.0
DR 8M-8	8	1/2 12.70	6.4	15	16	16.2	18.6	40.1	47.6
DR 10M-6	10	3/8 9.52	7.1	18	19	17.2	19.5	36.6	44.2
DR 10M-8	10	1/2 12.70	7.9	18	19	17.2	19.5	42.2	49.8
DR 12M-8	12	1/2 12.70	9.5	22	22	22.8	22.0	42.2	52.3
DR 12M-12	12	3/4 19.05	9.5	22	22	22.8	22.0	43.7	53.8
DR 18M-12	18	3/4 19.05	15.1	27	30	24.4	22.0	46.0	56.1
DR 18M-16	18	1 25.40	15.1	27	30	24.4	22.0	52.3	62.4
DR 25M-16	25	1 25.40	20.2	35	38	31.3	26.5	57.2	69.5

Connects metric tube to metric Dk-Lok port

Part No.	Tube O.D.		E Min.	Width across flat		A	B	l	L
	D	D ₁		h	H				
DR 2M-3M	2	3	1.7	12	12	12.9	15.3	26.9	35.3
DR 3M-4M	3	4	2.4	12	12	12.9	15.3	28.4	35.0
DR 3M-6M	3	6	2.4	12	12	12.9	15.3	29.5	36.1
DR 3M-10M	3	10	2.4	12	12	12.9	15.3	31.8	38.4
DR 4M-6M	4	6	2.4	12	12	13.7	16.1	30.5	37.1
DR 6M-3M	6	3	1.8	14	14	15.3	17.7	29.5	36.9
DR 6M-8M	6	8	4.8	14	14	15.3	17.7	32.5	39.9
DR 6M-10M	6	10	4.8	14	14	15.3	17.7	33.3	40.7
DR 6M-12M	6	12	4.8	14	14	15.3	17.7	38.9	46.3
DR 8M-6M	8	6	4.6	15	16	16.2	18.6	32.8	40.3
DR 8M-10M	8	10	6.4	15	16	16.2	18.6	34.5	42.0
DR 8M-12M	8	12	6.4	15	16	16.2	18.6	40.1	47.6
DR 10M-6M	10	6	4.6	18	19	17.2	19.5	34.8	42.4
DR 10M-12M	10	12	7.9	18	19	17.2	19.5	42.2	49.8
DR 10M-15M	10	15	7.9	18	19	17.2	19.5	43.7	51.3
DR 10M-18M	10	18	7.9	19	19	17.2	19.5	43.7	51.3
DR 12M-6M	12	6	4.6	22	22	22.8	22.0	34.8	44.9
DR 12M-10M	12	10	7.7	22	22	22.8	22.0	36.6	46.7
DR 12M-16M	12	16	9.5	22	22	22.8	22.0	43.7	53.8
DR 12M-18M	12	18	9.5	22	22	22.8	22.0	43.7	53.8
DR 12M-20M	12	20	9.5	22	22	22.8	22.0	46.0	56.1
DR 12M-22M	12	22	9.5	24	22	22.8	22.0	46.0	56.1
DR 12M-25M	12	25	9.5	27	22	22.8	22.0	52.3	62.4
DR 16M-12M	16	12	9.1	24	25	24.4	22.0	42.9	53.0
DR 18M-12M	18	12	9.1	27	30	24.4	22.0	44.5	54.6
DR 18M-16M	18	16	12.7	27	30	24.4	22.0	46.0	56.1
DR 18M-20M	18	20	15.1	27	30	24.4	22.0	47.5	57.6
DR 18M-22M	18	22	15.1	27	30	24.4	22.0	47.5	57.6
DR 18M-25M	18	25	15.1	27	30	24.4	22.0	52.3	62.4
DR 20M-16M	20	16	12.7	30	32	26.0	22.0	47.8	57.9
DR 20M-18M	20	18	13.9	30	32	26.0	22.0	47.8	57.9
DR 20M-22M	20	22	15.8	30	32	26.0	22.0	49.3	59.4
DR 20M-25M	20	25	15.8	30	32	26.0	22.0	54.1	64.2
DR 22M-18M	22	18	13.9	30	32	26.0	22.0	47.8	57.9
DR 22M-20M	22	20	15.1	30	32	26.0	22.0	49.3	59.4
DR 22M-25M	22	25	18.3	30	32	26.0	22.0	54.1	64.2
DR 25M-18M	25	18	13.9	35	38	31.3	26.5	50.8	63.1
DR 25M-20M	25	20	15.1	35	38	31.3	26.5	52.3	64.6

Dk-Lok Tube Fittings

Bulkhead Adapter DAB

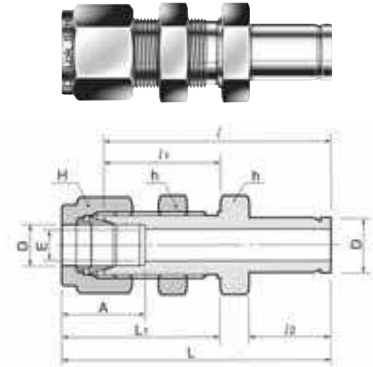
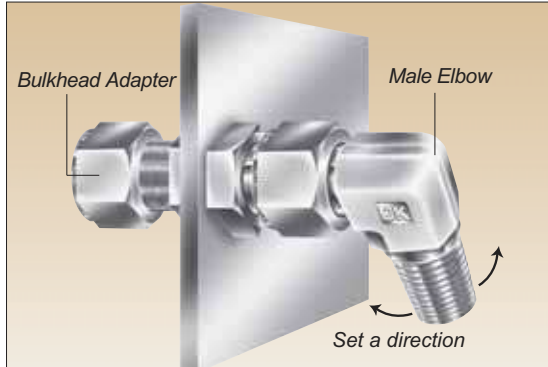

The bulkhead adapter is useful to help set a direction through panel construction.

Connects fractional tube to fractional Dk-Lok port

Part No.	Tube O.D. D		E Min.	Width across flat				A	l	l ₁	l ₂	L	L ₁	Panel Hole Drill Size	Panel Max Thickness
	in	mm		h	H	in	mm								
DAB 2-2	1/8	3.17	2.03	1/2	12.70	7/16	11.11	12.70	42.92	24.63	13.45	49.53	31.24	8.33	12.70
DAB 4-4	1/4	6.35	4.82	5/8	15.87	9/16	14.28	15.24	48.51	26.16	15.74	55.88	33.52	11.50	10.16
DAB 6-6	3/8	9.52	7.11	3/4	19.05	11/16	17.46	16.76	53.84	29.46	17.50	61.21	36.83	14.68	11.17
DAB 8-8	1/2	12.70	10.41	15/16	23.81	7/8	22.22	22.86	62.73	31.75	23.11	72.89	41.91	19.44	12.70
DAB10-10	5/8	15.87	12.70	1-1/16	26.98	1	25.40	24.38	65.02	32.51	24.70	75.18	42.67	22.62	12.70
DAB16-16	1	25.40	20.32	1-5/8	41.28	1-1/2	38.10	31.24	88.13	45.21	31.70	100.33	57.40	33.73	19.05
DAB20-20	1-1/4	31.75	27.68	1-7/8	47.63	1-7/8	47.63	41.14	102.07	47.75	40.00	124.17	69.85	41.67	19.05
DAB24-24	1-1/2	38.10	34.03	2-1/4	57.15	2-1/4	57.15	50.03	118.33	49.27	51.50	145.51	76.45	49.61	19.05
DAB32-32	2	50.80	45.97	2-3/4	69.85	3	76.20	67.56	148.79	56.38	68.40	185.82	93.71	57.94	19.05

Male Adapter DAM-N

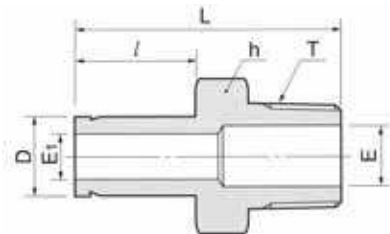

Connects metric Dk-Lok port to female NPT thread

Part No.	Tube O.D. D		T PT	E Min.	E ₁ Min.	Width across flat		L
	in	mm				h	l	
DAM 3M-2N	3	3	1/8	4.0	1.8	12	13.15	29.4
DAM 6M-2N	6	6	1/8	4.6	4.6	12	15.70	32.8
DAM 6M-4N	6	6	1/4	4.6	4.6	14	15.70	38.1
DAM 8M-4N	8	8	1/4	6.3	6.3	14	16.80	39.1
DAM 10M-4N	10	10	1/4	7.7	7.7	14	17.50	39.9
DAM 10M-6N	10	10	3/8	7.7	7.7	17	17.50	40.6
DAM 10M-8N	10	10	1/2	11.9	7.7	22	17.50	45.2
DAM 12M-4N	12	12	1/4	7.1	9.1	14	23.10	46.5
DAM 12M-6N	12	12	3/8	9.1	9.1	17	23.10	46.5
DAM 12M-8N	12	12	1/2	11.9	9.1	22	23.10	51.8
DAM 18M-8N	18	18	1/2	11.9	13.9	22	24.60	53.2
DAM 18M-12N	18	18	3/4	15.9	13.9	27	24.60	53.2
DAM 28M-16N	28	28	1	22.2	-	35	31.70	74.7
DAM 28M-20N	28	28	1-1/4	23.8	-	46	31.70	76.2
DAM 32M-20N	32	32	1-1/4	27.4	-	46	40.00	81.0
DAM 38M-24N	38	38	1-1/2	33.3	-	55	51.50	92.2

Male Adapter DAM-N

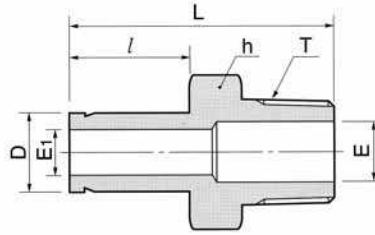
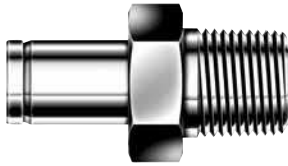

Connects fractional Dk-Lok port to female NPT thread

Part No.	Tube O.D. D		T NPT	E Min.	E ₁	Width across flat h		l	L
	in	mm				in	mm		
DAM 2-2N	1/8	3.17	1/8	4.57	1.77	7/16	11.11	13.45	29.50
DAM 2-4N	1/8	3.17	1/4	7.11	1.77	9/16	14.28	13.45	34.80
DAM 3-2N	3/16	4.76	1/8	4.57	3.04	7/16	11.11	14.20	30.22
DAM 3-4N	3/16	4.76	1/4	7.11	3.04	9/16	14.28	14.20	35.56
DAM 4-2N	1/4	6.35	1/8	4.57	4.57	7/16	11.11	15.75	31.80
DAM 4-4N	1/4	6.35	1/4	7.11	4.57	9/16	14.28	15.75	37.08
DAM 4-6N	1/4	6.35	3/8	10.41	4.57	11/16	17.46	15.75	37.84
DAM 4-8N	1/4	6.35	1/2	12.70	4.57	7/8	22.22	15.75	43.43
DAM 5-2N	5/16	7.93	1/8	4.57	6.35	7/16	11.11	16.80	32.76
DAM 5-4N	5/16	7.93	1/4	7.11	6.35	9/16	14.28	16.80	38.10
DAM 6-2N	3/8	9.52	1/8	4.57	7.11	7/16	11.11	17.50	33.50
DAM 6-4N	3/8	9.52	1/4	7.11	7.11	9/16	14.28	17.50	38.90
DAM 6-6N	3/8	9.52	3/8	10.41	7.11	11/16	17.46	17.50	39.60
DAM 6-8N	3/8	9.52	1/2	12.70	7.11	7/8	22.22	17.50	45.20
DAM 8-4N	1/2	12.70	1/4	7.11	9.90	9/16	14.28	23.20	44.50
DAM 8-6N	1/2	12.70	3/8	10.41	9.90	11/16	17.46	23.20	45.20
DAM 8-8N	1/2	12.70	1/2	12.70	9.90	7/8	22.22	23.20	50.50
DAM 10-6N	5/8	15.87	3/8	10.41	12.70	11/16	17.46	24.70	47.40
DAM 10-8N	5/8	15.87	1/2	12.70	12.70	7/8	22.22	24.70	52.30
DAM 10-12N	5/8	15.87	3/4	18.28	12.70	1-1/16	26.98	24.70	52.30
DAM 12-8N	3/4	19.05	1/2	12.70	14.98	7/8	22.22	24.70	52.30
DAM 12-12N	3/4	19.05	3/4	18.28	14.98	1-1/16	26.98	24.70	52.30
DAM 12-16N	3/4	19.05	1	22.35	14.98	1-3/8	34.92	24.70	57.91
DAM 14-12N	7/8	22.22	3/4	18.28	17.27	1-1/16	26.98	26.70	54.30
DAM 16-12N	1	25.40	3/4	18.28	20.06	1-1/16	26.98	31.70	58.70
DAM 16-16N	1	25.40	1	22.35	20.06	1-3/8	34.92	31.70	66.00
DAM 20-20N	1-1/4	31.75	1-1/4	27.68	-	1-3/4	44.45	40.00	80.26
DAM 24-24N	1-1/2	38.10	1-1/2	33.27	-	2-1/8	53.98	51.50	94.48
DAM 32-32N	2	50.80	2	44.45	-	2-3/4	69.85	68.40	119.38

Dk-Lok Tube Stub Adapter eliminates alignment problems

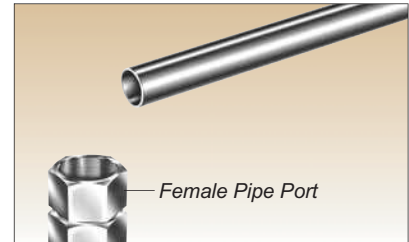

In the direction shown the female port is required to connect with tubing.

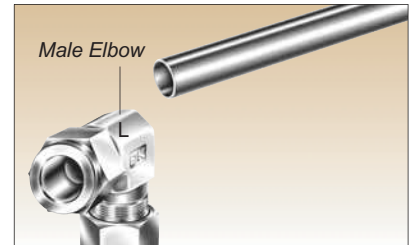

The male elbow is positioning in the wrong direction.

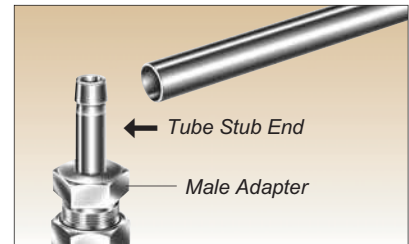

To eliminate the problem, use a male adapter into the female port.

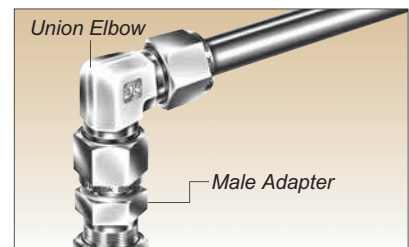

Installation instruction.

1. Insert the tube stub end into the Dk-Lok port
 - Make sure that the tube stub end bottoms on the fitting body shoulder.
2. Spanner-tighten the nut 1 1/4 turns beyond the finger tight position.
 - Tighten the nut 3/4 turn for 1/8, and 3/16 in.; 3, and 4 mm tube fittings.

Note: For re-use, see re-assembly instruction.

Dk-Lok Tube Fittings

Male Adapter DAM-R

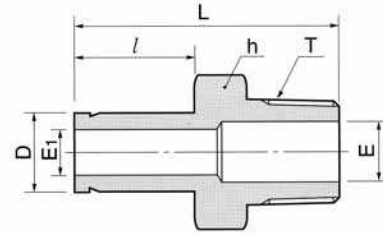
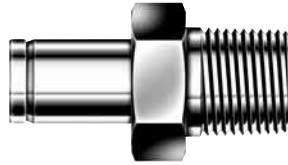

Connects fractional Dk-Lok port to female ISO tapered thread

Part No.	Tube O.D. D		T PT	E Min.	E ₁	Width across flat h		l	L
	in	mm				in	mm		
DAM 2-2R	1/8	3.17	1/8	4.57	1.77	7/16	11.11	13.45	29.50
DAM 2-4R	1/8	3.17	1/4	7.11	1.77	9/16	14.28	13.45	34.80
DAM 4-2R	1/4	6.35	1/8	4.57	4.57	7/16	11.11	15.75	31.80
DAM 4-4R	1/4	6.35	1/4	7.11	4.57	9/16	14.28	15.75	37.08
DAM 4-6R	1/4	6.35	3/8	10.41	4.57	11/16	17.46	15.75	37.84
DAM 6-4R	3/8	9.52	1/4	7.11	7.11	9/16	14.28	17.50	38.90
DAM 6-6R	3/8	9.52	3/8	10.41	7.11	11/16	17.46	17.50	39.60
DAM 6-8R	3/8	9.52	1/2	12.70	7.11	7/8	22.22	17.50	45.20
DAM 8-4R	1/2	12.70	1/4	7.11	9.90	9/16	14.28	23.10	44.50
DAM 8-6R	1/2	12.70	3/8	10.41	9.90	11/16	17.46	23.10	45.20
DAM 8-8R	1/2	12.70	1/2	12.70	9.90	7/8	22.22	23.10	50.50
DAM 8-12R	1/2	12.70	3/4	15.74	9.90	1-1/16	26.98	23.10	50.70
DAM 12-8R	3/4	19.05	1/2	12.70	14.98	7/8	22.22	24.70	52.30
DAM 12-12R	3/4	19.05	3/4	14.98	14.98	1-1/16	26.98	24.70	52.30

Connects metric Dk-Lok port to female ISO tapered thread

Part No.	Tube O.D. D		T PT	E Min.	E ₁	Width across flat h		l	L
	in	mm				in	mm		
DAM 3M-2R	3	3	1/8	4.0	1.8	12	12	13.15	29.4
DAM 6M-2R	6	6	1/8	4.6	4.6	12	12	15.70	32.8
DAM 6M-4R	6	6	1/4	4.6	4.6	14	14	15.70	38.1
DAM 8M-4R	8	8	1/4	6.3	6.3	14	14	16.80	39.1
DAM 10M-4R	10	10	1/4	7.7	7.7	14	14	17.50	39.9
DAM 10M-6R	10	10	3/8	7.7	7.7	17	17	17.50	40.6
DAM 10M-8R	10	10	1/2	11.9	7.7	22	22	17.50	45.2
DAM 12M-4R	12	12	1/4	7.1	9.1	14	14	23.10	46.5
DAM 12M-6R	12	12	3/8	9.1	9.1	17	17	23.10	46.5
DAM 12M-8R	12	12	1/2	11.9	9.1	22	22	23.10	51.8
DAM 18M-8R	18	18	1/2	11.9	13.9	22	22	24.60	53.2
DAM 18M-12R	18	18	3/4	15.9	13.9	27	27	24.60	53.2
DAM 25M-16R	25	25	1	19.8	19.8	35	35	31.70	66.0
DAM 28M-16R	28	28	1	22.2	-	35	35	31.70	74.7
DAM 28M-20R	28	28	1-1/4	23.8	-	46	46	31.70	76.2
DAM 30M-20R	30	30	1-1/4	24.6	-	46	46	40.6	80.0
DAM 32M-20R	32	32	1-1/4	27.4	-	46	46	40.00	81.0
DAM 38M-24R	38	38	1-1/2	33.3	-	55	55	51.50	92.2

Male Adapter DAM-G

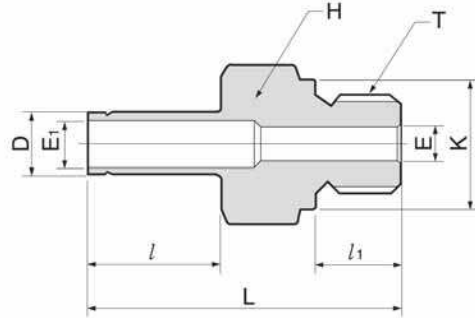

Connects fractional Dk-Lok port to female ISO parallel thread

Part No.	Tube O.D. D		T PF	E Min.	E ₁	Width across flat h		l	l ₁	L	K
	in	mm				in	mm				
DAM 2-2G	1/8	3.17	1/8	1.77	1.77	9/16	14.28	13.45	7.10	40.0	13.8
DAM 2-4G	1/8	3.17	1/4	6.4	1.77	3/4	19.05	13.45	11.2	35.8	18.0
DAM 4-2G	1/4	6.35	1/8	4.57	4.57	9/16	14.28	15.75	7.10	33.27	13.8
DAM 4-4G	1/4	6.35	1/4	4.57	4.57	3/4	19.05	15.75	11.2	38.1	18.0
DAM 6-4G	3/8	9.52	1/4	5.9	7.1	3/4	19.05	17.50	11.2	39.8	18.0
DAM 6-6G	3/8	9.52	3/8	7.11	7.11	7/8	22.22	17.5	11.2	40.64	21.8
DAM 8-4G	1/2	12.70	1/4	5.9	9.9	3/4	19.05	23.1	11.2	45.5	18.0
DAM 8-6G	1/2	12.70	3/8	7.9	9.9	7/8	22.22	23.1	11.2	46.2	21.8
DAM 8-8G	1/2	12.70	1/2	11.9	9.9	1-1/16	26.98	23.1	14.2	49.3	26.0
DAM 12-12G	3/4	19.05	3/4	14.98	14.98	1-5/16	33.33	24.7	15.7	54.86	32.0
DAM 16-16G	1	25.40	1	20.06	20.06	1-5/8	41.28	31.7	18.3	64.5	39.0

Connects metric Dk-Lok port to female ISO parallel thread

Part No.	Tube O.D. D		T PF	E Min.	E ₁	Width across flat h		l	l ₁	L	K
	in	mm				in	mm				
DAM 6M-2G	6		1/8	4.6	4.6	14	15.7	15.7	7.1	34.3	13.8
DAM 6M-4G	6		1/4	4.6	4.6	19	15.7	15.7	11.2	39.1	18.0
DAM 8M-4G	8		1/4	5.9	5.9	19	16.8	16.8	11.2	40.1	18.0
DAM 10M-4G	10		1/4	5.9	7.7	19	17.5	17.5	11.2	40.9	18.0
DAM 10M-6G	10		3/8	7.7	7.7	22	17.5	17.5	11.2	41.7	21.8
DAM 10M-8G	10		1/2	7.7	7.7	27	17.5	17.5	14.2	44.7	26.0
DAM 12M-4G	12		1/4	5.9	9.1	19	23.1	23.1	11.2	46.7	18.0
DAM 12M-6G	12		3/8	7.9	9.1	22	23.1	23.1	11.2	47.2	21.8
DAM 12M-8G	12		1/2	9.1	9.1	27	23.1	23.1	14.2	50.5	26.0
DAM 18M-8G	18		1/2	11.9	13.9	27	24.6	24.6	14.2	52.1	26.0
DAM 18M-12G	18		3/4	15.9	13.9	35	24.6	24.6	15.7	56.1	32.0
DAM 22M-12G	22		3/4	15.9	18.3	35	26.6	26.6	15.7	57.4	32.0
DAM 25M-16G	25		1	19.8	19.8	41	31.7	31.7	18.3	67.1	39.0
DAM 28M-16G	28		1	19.8	22.2	41	37.5	37.5	18.3	72.9	39.0
DAM 28M-20G	28		1-1/4	23.8	23.8	50	37.5	37.5	19.8	77.0	49.0
DAM 30M-20G	30		1-1/4	24.6	24.6	50	40.66	40.66	19.8	80.8	49.0
DAM 32M-20G	32		1-1/4	25.0	25.0	50	40.0	40.0	19.8	81.8	49.0
DAM 38M-24G	38		1-1/2	31.8	31.8	55	50.4	50.4	22.1	94.5	54.7

Dk-Lok Tube Fittings

Male Adapter DAM-U

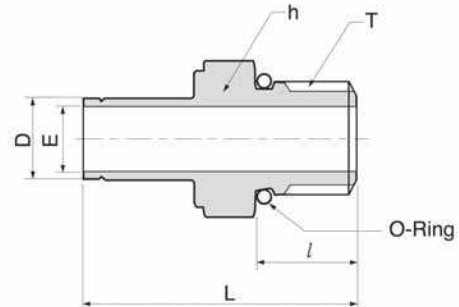
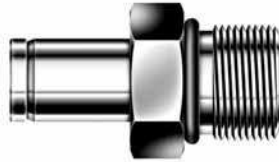

Connects fractional Dk-Lok port to SAE straight thread boss

Part No.	Tube O.D. D		T U	E Min.	Width across flat h		l	L	o-ring Uniform Size Number
	in	mm			in	mm			
DAM 2-2U	1/8	3.17	5/16-24	2.03	7/16	11.11	7.62	30.48	-902
DAM 4-4U	1/4	6.35	7/16-20	4.31	9/16	14.28	9.14	35.30	-904
DAM 6-4U	3/8	9.52	7/16-20	5.08	9/16	14.28	9.14	37.08	-904
DAM 6-6U	3/8	9.52	9/16-18	6.85	11/16	17.46	9.90	38.60	-906
DAM 6-8U	3/8	9.52	3/4-16	6.85	7/8	22.22	11.17	40.64	-908
DAM 8-6U	1/2	12.70	9/16-18	7.11	11/16	17.46	9.90	44.20	-906
DAM 8-8U	1/2	12.70	3/4-16	9.9	7/8	22.22	11.17	46.22	-908
DAM 12-12U	3/4	19.05	1-1/16-12	14.98	1-1/4	31.75	14.98	53.34	-912
DAM 16-16U	1	25.4	1-5/16-12	20.31	1-1/2	38.1	14.98	61.21	-916

Male Adapter DAM-UO

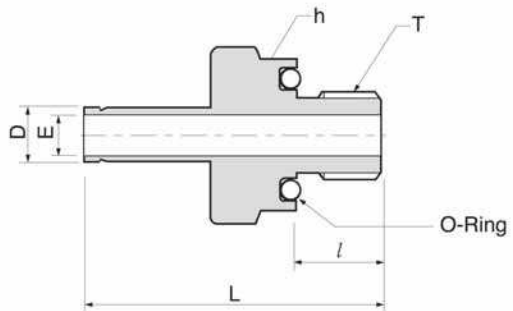
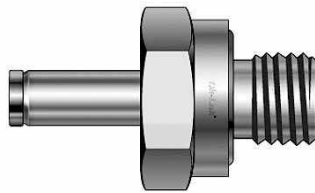

Connects fractional Dk-Lok port to SAE straight thread boss

Part No.	Tube O.D. D		T U	E Min.	Width across flat h		l	L	o-ring Uniform Size Number
	in	mm			in	mm			
DAM 2-2UO	1/8	3.17	5/16-24	2.03	9/16	14.28	8.63	32.51	-011
DAM 3-3UO	3/16	4.76	3/8-24	3.05	5/8	15.87	9.65	35.05	-012
DAM 4-4UO	1/4	6.35	7/16-20	4.32	3/4	19.05	10.41	39.11	-013
DAM 5-5UO	5/16	7.93	1/2-20	5.59	7/8	22.22	11.17	41.65	-112
DAM 6-6UO	3/8	9.52	9/16-18	6.85	15/16	23.81	11.93	43.18	-113
DAM 8-8UO	1/2	12.7	3/4-16	9.40	1-1/8	28.57	11.93	49.53	-116

Female Adapter DAF-N

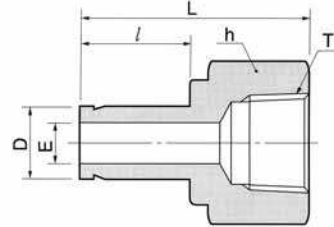

Connects fractional Dk-Lok port to male NPT thread

Part No.	Tube O.D. D		T NPT	E Min.	Width across flat h		l	L
	in	mm			in	mm		
DAF 2-2N	1/8	3.17	1/8	1.77	9/16	14.28	13.45	31.50
DAF 2-4N	1/8	3.17	1/4	1.77	3/4	19.05	13.45	35.30
DAF 3-2N	3/16	4.76	1/8	3.04	9/16	14.28	14.20	32.00
DAF 3-4N	3/16	4.76	1/4	3.04	3/4	19.05	14.20	35.81
DAF 4-2N	1/4	6.35	1/8	4.57	9/16	14.28	15.75	33.02
DAF 4-4N	1/4	6.35	1/4	4.57	3/4	19.05	15.75	37.10
DAF 4-6N	1/4	6.35	3/8	4.57	7/8	22.22	15.75	39.37
DAF 4-8N	1/4	6.35	1/2	4.57	1-1/16	26.98	15.75	45.50
DAF 5-2N	5/16	7.93	1/8	6.35	9/16	14.28	16.80	34.29
DAF 5-4N	5/16	7.93	1/4	6.35	3/4	19.05	16.80	37.59
DAF 6-2N	3/8	9.52	1/8	7.11	9/16	14.28	17.50	34.29
DAF 6-4N	3/8	9.52	1/4	7.11	3/4	19.05	17.50	38.10
DAF 6-6N	3/8	9.52	3/8	7.11	7/8	22.22	17.50	40.38
DAF 6-8N	3/8	9.52	1/2	7.11	1-1/16	26.98	17.50	46.73
DAF 8-4N	1/2	12.70	1/4	9.90	3/4	19.05	23.20	43.43
DAF 8-6N	1/2	12.70	3/8	9.90	7/8	22.22	23.20	45.46
DAF 8-8N	1/2	12.70	1/2	9.90	1-1/16	26.98	23.20	51.80
DAF 10-6N	5/8	15.87	3/8	12.70	7/8	22.22	24.70	48.26
DAF 10-8N	5/8	15.87	1/2	12.70	1-1/16	26.98	24.70	53.84
DAF 10-12N	5/8	15.87	3/4	12.70	1-5/16	33.33	24.70	55.37
DAF 12-8N	3/4	19.05	1/2	14.98	1-1/16	26.98	24.70	52.83
DAF 12-12N	3/4	19.05	3/4	14.98	1-5/16	33.33	24.70	54.86
DAF 12-16N	3/4	19.05	1	14.98	1-5/8	41.27	24.70	58.42
DAF 14-12N	7/8	22.22	3/4	17.27	1-5/16	33.33	26.70	57.15
DAF 16-12N	1	25.40	3/4	20.06	1-5/16	33.33	31.70	60.70
DAF 16-16N	1	25.40	1	20.06	1-5/8	41.27	31.70	64.26
DAF 20-20N	1-1/4	31.75	1-1/4	27.68	2-1/8	53.98	40.00	77.72
DAF 24-24N	1-1/2	38.10	1-1/2	33.27	2-3/8	60.33	51.50	88.90
DAF 32-32N	2	50.80	2	44.45	2-7/8	73.03	68.40	107.44

Connects metric Dk-Lok port to male NPT thread

Part No.	Tube O.D. D		T NPT	E Min.	Width across flat h		l	L
	mm				mm			
DAF 6M-2N	6		1/8	4.6	14		15.70	32.50
DAF 6M-4N	6		1/4	4.6	19		15.70	37.10
DAF 8M-4N	8		1/4	6.3	19		16.80	37.60
DAF 10M-4N	10		1/4	7.7	19		17.50	38.10
DAF 10M-6N	10		3/8	7.7	22		17.50	40.10
DAF 10M-8N	10		1/2	7.7	27		17.50	46.50
DAF 12M-4N	12		1/4	9.1	19		23.10	43.70
DAF 12M-6N	12		3/8	9.1	22		23.10	46.00
DAF 12M-8N	12		1/2	9.1	27		23.10	52.30

Dk-Lok Tube Fittings

Female Adapter DAF-R

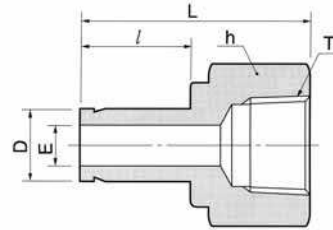

Connects fractional Dk-Lok port to male ISO tapered thread

Part No.	Tube O.D. D		T PT	E Min.	Width across flat h		l	L
	in	mm			in	mm		
DAF 4-2R	1/4	6.35	1/8	4.57	9/16	14.28	15.75	33.02
DAF 4-4R	1/4	6.35	1/4	4.57	3/4	19.05	15.75	37.10
DAF 6-4R	3/8	9.52	1/4	7.11	3/4	19.05	17.50	38.10
DAF 6-6R	3/8	9.52	3/8	7.11	7/8	22.22	17.50	40.38
DAF 8-4R	1/2	12.70	1/4	9.90	3/4	19.05	23.20	43.43
DAF 8-6R	1/2	12.70	3/8	9.90	7/8	22.22	23.20	45.46
DAF 8-8R	1/2	12.70	1/2	9.90	1-1/16	26.98	23.20	51.80
DAF10-8R	5/8	15.87	1/2	12.70	1-1/16	26.98	24.70	53.84
DAF12-8R	3/4	19.05	1/2	14.98	1-1/16	26.98	24.70	52.83
DAF12-12R	3/4	19.05	3/4	14.98	1-5/16	33.33	24.70	54.86
DAF 16-16R	1	25.40	1	20.06	1-5/8	41.27	31.70	64.26

Connects metric Dk-Lok port to male ISO tapered thread

Part No.	Tube O.D. D		T PT	E Min.	Width across flat h		l	L
	in	mm			in	mm		
DAF 6M-2R	6	6	1/8	4.6	14	15.70	32.50	
DAF 6M-4R	6	6	1/4	4.6	19	15.70	37.10	
DAF 8M-4R	8	8	1/4	6.3	19	16.80	37.60	
DAF 10M-4R	10	10	1/4	7.7	19	17.50	38.10	
DAF 10M-6R	10	10	3/8	7.7	22	17.50	40.10	
DAF 12M-4R	12	12	1/4	9.1	19	23.10	43.70	
DAF 12M-6R	12	12	3/8	9.1	22	23.10	46.00	
DAF 12M-8R	12	12	1/2	9.1	27	23.10	52.30	

Female Adapter DAF-GR

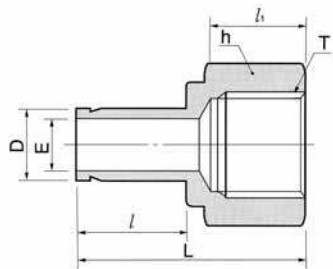

Connects fractional Dk-Lok port to male ISO parallel thread

Part No.	Tube O.D. D		T PF	E Min.	Width across flat h		l	l ₁	L
	in	mm			in	mm			
DAF 4-2GR	1/4	6.35	1/8	4.57	9/16	13.0	15.75	13.0	33.02
DAF 4-4GR	1/4	6.35	1/4	4.57	3/4	18.5	15.75	18.5	37.10
DAF 6-4GR	3/8	9.52	1/4	7.11	3/4	18.5	17.50	18.5	38.10
DAF 6-6GR	3/8	9.52	3/8	7.11	7/8	18.5	17.50	18.5	40.38
DAF 8-8GR	1/2	12.70	1/2	9.90	1-1/16	22.1	23.20	22.1	49.53

Connects metric Dk-Lok port to male ISO parallel thread

Part No.	Tube O.D. D		T PF	E Min.	Width across flat h		l	l ₁	L
	in	mm			in	mm			
DAF 6M-2GR	6	6	1/8	4.6	14	15.70	13.0	32.50	
DAF 6M-4GR	6	6	1/4	4.6	19	15.70	18.5	37.10	
DAF 12M-8GR	12	12	1/2	9.1	27	23.10	22.1	49.50	

Female Gauge Adapter
(previously **DAG**)
DAF-GG

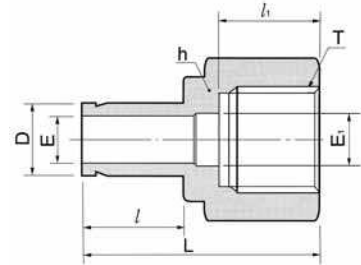

Connects fractional Dk-Lok port to Gauge (Male ISO parallel thread)

Part No.	Tube O.D. D		T G(PF)	E Min.	E ₁	Width across flat h		l	l ₁	L
	in	mm				in	mm			
DAF 4-2GG	1/4	6.35	1/8	4.57	4.57	9/16	14.28	15.75	12.0	32.00
DAF 4-4GG	1/4	6.35	1/4	4.57	5.5	3/4-	19.05	15.75	12.9	35.30
DAF 6-6GG	3/8	9.52	3/8	6.60	6.5	15/16	23.81	17.50	14.1	39.37
DAF 8-8GG	1/2	12.7	1/2	7.11	7.0	1-1/16	26.98	23.20	18.9	45.72

Connects metric Dk-Lok port to Gauge (Male ISO parallel thread)

Part No.	Tube O.D. D		T G(PF)	E Min.	E ₁	Width across flat h		l	l ₁	L
DAF 6M-2GG	6M		1/8	4.0	4.0	14	15.7	12.0	32.0	
DAF 6M-4GG	6M		1/4	4.0	5.5	19	15.7	13.0	35.3	
DAF 6M-6GG	6M		3/8	4.0	6.5	24	15.7	14.22	38.4	
DAF 6M-8GG	6M		1/2	4.0	7.0	27	15.7	18.9	42.9	
DAF 8M-4GG	8M		1/4	5.6	5.5	19	16.8	13.0	33.0	
DAF 8M-6GG	8M		3/8	5.6	6.5	24	16.8	14.22	39.3	
DAF 8M-8GG	8M		1/2	5.6	7.0	27	16.8	18.9	43.7	
DAF 10M-4GG	10M		1/4	7.7	5.5	19	17.5	13.0	34.5	
DAF 10M-6GG	10M		3/8	7.7	6.5	24	17.5	14.22	39.3	
DAF 10M-8GG	10M		1/2	7.7	7.0	27	17.5	18.9	40.1	
DAF 12M-4GG	12M		1/4	9.1	5.5	19	23.1	13.0	40.1	
DAF 12M-6GG	12M		3/8	9.1	6.5	24	23.1	14.22	44.9	
DAF 12M-8GG	12M		1/2	9.1	7.0	27	23.1	18.9	48.8	
DAF 15M-8GG	15M		1/2	12.0	7.0	27	24.65	18.9	49.0	
DAF 16M-8GG	16M		1/2	12.0	7.0	27	24.6	18.9	49.0	
DAF 18M-8GG	18M		1/2	13.9	7.0	27	24.9	18.9	49.3	
DAF 22M-8GG	22M		1/2	18.3	7.0	27	26.6	18.9	52.0	
DAF 25M-8GG	25M		1/2	19.8	7.0	30	31.7	18.9	56.1	

Dk-Lok Tube Fittings

Elbow Adapter DLA

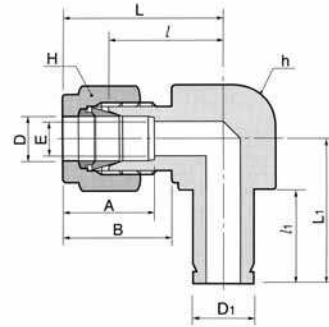

Connects metric tube to metric Dk-Lok port.

Part No.	Tube O.D. D	D ₁	E Min.	Width across flat		A	B	l	l ₁	L	L ₁
				h	H						
DLA-6M	6	6	4.6	12.7	14	15.3	17.7	19.6	15.7	27.0	25.0
DLA-8M	8	8	6.4	15.8	16	16.2	18.6	21.3	16.8	28.8	27.05
DLA-10M	10	10	7.7	17.4	19	17.2	19.5	23.9	17.5	31.5	30.0
DLA-12M	12	12	9.1	20.6	22	22.8	22.0	25.9	23.1	36.0	37.3
DLA-14M	14	14	11.1	25.4	25	24.4	22.0	28.7	24.6	38.8	41.5
DLA-15M	15	15	11.9	25.4	25	24.4	22.0	28.7	24.65	38.8	41.55
DLA-16M	16	16	12.7	25.4	25	24.4	22.0	28.7	24.6	38.8	41.5
DLA-18M	18	18	13.9	26.9	30	24.4	22.0	29.7	24.6	39.8	42.5
DLA-20M	20	20	15.1	31.8	32	26.0	22.0	32.5	26.2	42.6	47.0
DLA-22M	22	22	18.3	31.8	32	26.0	22.0	32.5	26.6	42.6	47.15
DLA-25M	25	25	19.8	34.9	38	31.3	26.5	36.8	31.7	49.1	55.2
DLA-28M	28	28	21.8	41.0	46	36.6	36.6	43.2	37.5	64.0	64.9

Run Tee Adapter DTRA

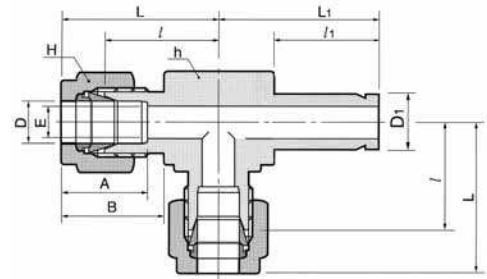

Connects metric tube to metric Dk-Lok port.

Part No.	Tube O.D. D	D ₁	E Min.	Width across flat		A	B	l	l ₁	L	L ₁
				h	H						
DTRA-8M	8	8	6.4	15.8	16	16.2	18.6	21.3	16.8	28.8	27.5
DTRA-10M	10	10	7.9	17.4	19	17.2	19.5	23.9	17.5	31.5	30.0

Branch Tee Adapter DTBA

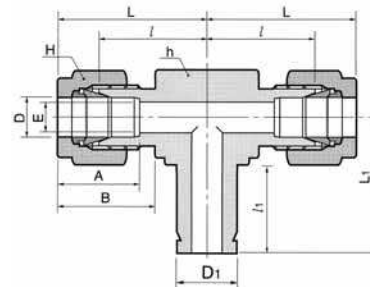

Connects metric tube to metric Dk-Lok ports

Part No.	Tube O.D. D	D ₁	E Min.	Width across flat		A	B	l	l ₁	L	L ₁
				h	H						
DTBA-8M	8	8	6.4	15.8	16	16.2	18.6	21.3	16.8	28.8	27.5

Port Connector DCP

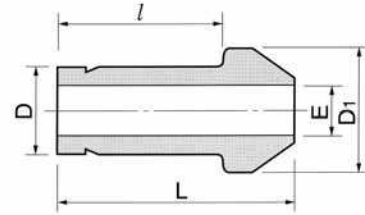
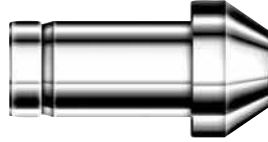

Connects two fractional Dk-Lok ports

Part No.	Tube O.D.		E Min.	D ₁	l	L
	in	mm				
DCP-1	1/16	1.59	1.00	3.30	10.66	13.72
DCP-2	1/8	3.17	1.77	6.09	15.75	22.35
DCP-4	1/4	6.35	4.57	9.39	18.79	24.64
DCP-5	5/16	7.93	6.35	10.92	20.06	25.90
DCP-6	3/8	9.52	7.11	12.70	20.32	26.16
DCP-8	1/2	12.70	9.90	15.74	25.90	35.81
DCP-12	3/4	19.05	14.98	22.09	27.68	37.33
DCP-16	1	25.40	20.06	28.44	34.54	48.00

Connects two metric Dk-Lok ports

Part No.	Tube O.D.		E Min.	D ₁	l	L
	D					
DCP-3M	3		2.1	6.0	15.70	22.20
DCP-4M	4		2.2	7.0	16.67	25.81
DCP-6M	6		4.4	9.0	18.70	24.60
DCP-8M	8		6.2	11.0	20.00	25.90
DCP-10M	10		8.2	13.1	20.20	26.10
DCP-12M	12		9.1	15.0	26.00	35.80
DCP-15M	15		12.7	19.0	27.78	37.40
DCP-16M	16		12.7	19.0	27.60	37.40
DCP-18M	18		13.9	21.0	27.91	37.40
DCP-20M	20		15.1	23.0	29.20	38.90
DCP-22M	22		17.9	24.97	29.30	39.20
DCP-25M	25		19.8	28.0	34.50	48.00
DCP-28M	28		23.8	34.3	48.30	63.50
DCP-32M	32		27.4	39.5	52.40	69.70
DCP-38M	38		33.3	47.1	61.40	81.90

Installation Instructions

Machined Ferrule End and Tube Stub End

Port connector is useful for close connection of two Dk-Lok ports.

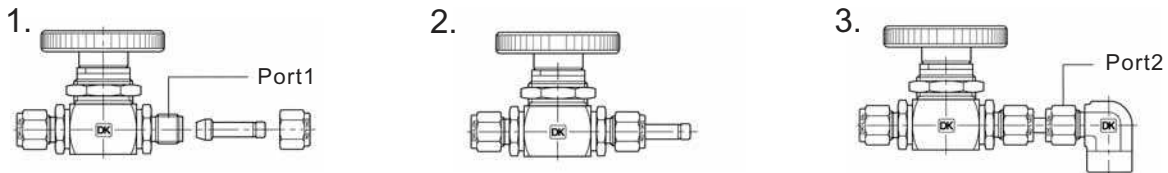

Be aware that Port Connector consists of machined ferrule end, and tube stub end. These two ends require different installation.

Machined Ferrule End

Refers to Fig. 1 & 2.

1. Remove the nut and ferrules from Dk-Lok port 1.
2. Place the nut over the machined ferrule end of the port connector.
3. Finger-tighten the nut onto the port 1.
4. Wrench-tighten the nut 1/4 turn, keeping the body steady with a backup wrench.
 - Do not tighten 1 1/4 turns. This is not the standard ferrule.
 - Tightens 1/8 turn for 1/16, and 1/8 in.; 3, and 4mm tube fittings.

Tube Stub End

Refers to Fig. 3.

1. Insert the tube stub end into the port 2 until it is bottomed on the shoulder of the body.
2. Finger-tighten the nut on port 2.
3. Wrench-tighten the nut 1/4 turns, keeping the port 2 body steady with a backup wrench.
 - Tighten the nut 3/4 turn for 1/16. and 1/8 in.; and 3, and 4mm tube fittings.
 - For re-use, see re-assembly instruction.

Dk-Lok Tube Fittings

Reducing Port Connector DCRP

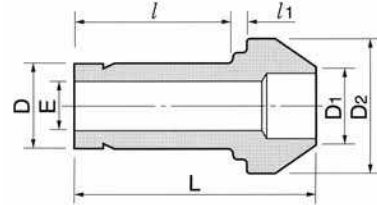
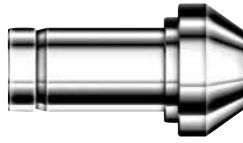

Connects two fractional Dk-Lok ports

Part No.	Tube O.D.				E Min.	D ₂	l	l ₁	L
	D ₁		D						
	in	mm	in	mm					
DCRP 2-1	1/8	3.17	1/16	1.59	1.00	6.10	8.64	2.03	17.27
DCRP 4-2	1/4	6.35	1/8	3.17	2.28	9.39	13.45	3.30	22.60
DCRP 6-2	3/8	9.52	1/8	3.17	2.28	12.70	13.45	3.81	23.11
DCRP 6-4	3/8	9.52	1/4	6.35	4.82	12.70	15.75	3.30	24.89
DCRP 8-4	1/2	12.70	1/4	6.35	4.82	15.74	15.75	3.81	29.21
DCRP 8-6	1/2	12.70	3/8	9.52	7.11	15.74	17.67	3.30	30.48
DCRP 12-8	3/4	19.05	1/2	12.70	9.90	22.09	23.20	3.81	37.85
DCRP 16-8	1	25.40	1/2	12.70	9.90	28.40	24.47	4.82	42.67
DCRP 16-12	1	25.40	3/4	19.05	14.98	28.40	25.90	4.06	43.43

Connects two metric Dk-Lok ports

Part No.	Tube O.D.		E Min.	D ₂	l	l ₁	L
	D ₁	D					
DCRP 6M-3M	6	3	2.2	9.0	13.50	3.2	22.60
DCRP 8M-6M	8	6	4.6	11.0	15.70	3.1	24.70
DCRP 10M-6M	10	6	4.6	13.1	15.70	3.4	25.00
DCRP 10M-8M	10	8	6.4	13.1	16.80	3.1	26.00
DCRP 12M-6M	12	6	4.6	15.0	15.70	3.6	29.10
DCRP 12M-8M	12	8	6.4	15.0	16.80	3.4	29.80
DCRP 12M-10M	12	10	7.7	15.0	17.50	3.1	30.40
DCRP 16M-6M	16	6	4.6	19.0	15.75	3.6	30.40
DCRP 16M-12M	16	12	9.1	19.0	23.10	3.4	36.20
DCRP 28M-25M	28	25	19.8	34.3	33.00	8.2	56.50
DCRP 32M-25M	32	25	19.8	39.5	33.00	9.9	60.30
DCRP 38M-25M	38	25	19.8	47.1	33.00	12.3	65.80

Dk-Lok Flanges ANSI B16.5 DF

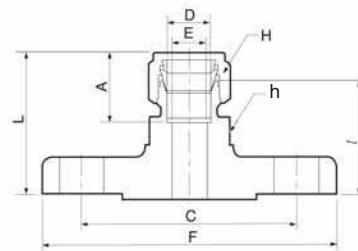

Pressure Class Ratings 150 to 2500
Nominal Flange Sizes NPS 1/2 to 2 in.
Connects ANSI flange to fractional tube

Part No.	Tube O.D.		ANSI Flange NPS	ANSI Class	E	Wrench Flat h	A	l	L	C	F
	D	D									
	in	mm									
DF-4TF8-150	1/4	6.35	1/2	150	4.82	23.81	15.24	33.52	40.89	60.45	88.9
DF-4TF16-150			1	150	4.82	23.81	15.24	36.35	43.71	79.2	108
DF-6TF8-150	3/8	9.52	1/2	150	4.82	23.81	16.76	34.85	42.21	60.45	88.9
DF-6TF8-300			1/2	300	7.11	23.81	16.76	38.1	45.46	66.54	95.25
DF-6TF16-150	1/2	12.7	1	150	7.11	23.81	16.76	37.85	45.21	79.2	108
DF-8TF8-150			1/2	150	10.41	23.81	22.86	30.05	45.21	60.45	88.9
DF-8TF8-300			1/2	300	10.41	23.81	22.86	37.85	48.01	66.54	95.25
DF-8TF8-1500			1/2	1500	10.41	23.81	22.86	46.05	56.21	82.6	121
DF-8TF16-150			1	150	10.41	23.81	22.86	38.1	48.26	79.24	48.26
DF-8TF32-150			2	150	10.41	23.81	22.86	42.92	53.08	42.92	53.08
DF-12TF16-150	3/4	19.05	1	150	15.74	31.75	24.38	40.13	50.29	79.24	107.95
DF-12TF16-900			1	900	15.74	31.75	24.38	46.05	56.21	101.6	149
DF-16TF16-150	1	25.4	1	150	22.35	34.92	31.24	48.26	60.45	79.24	107.95
DF-24TF32-150	1-1/2	38.1	2	150	34.03	53.97	50.03	59.18	86.36	120.65	152.4
DF-32TF32-150	2	50.8	2	150	45.97	69.85	67.56	67.05	104.39	120.65	152.4

Dk-Lok Flanges DIN 2526 / DIN 2501

DF

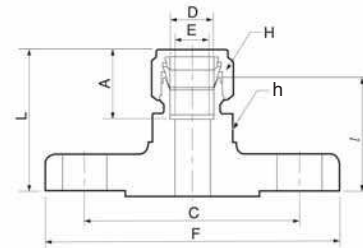

Pressure Class Rating PN 40 to 320, Nominal Flange Sizes DN 15 to 50
Connects DIN flange to metric tube

Part No.	Tube O.D. D	DIN Flange Size, DN	DIN CLASS	E	Wrench Flat h	A	l	L	C	F
DF-6MF25M-40	6 mm	25	40	4.8	20	15.3	40.1	47.5	85.0	115.0
DF-12MF15M-40	12 mm	15	40	9.5	20	22.8	38.4	48.5	65.0	95.0
DF-12MF25M-40		25	40	9.5	20	22.8	40.4	50.5	85.0	115.0
DF-12MF50M-40	18 mm	50	40	9.5	20	22.8	45.2	55.3	125.0	165.0
DF-18MF15M-40		15	40	15.1	32	24.4	41.7	51.8	65.0	95.0
DF-18MF15M-40	18 mm	25	40	15.1	32	24.4	43.7	53.8	85.0	115.0
DF-25MF25M-40	25 mm	25	40	21.8	35	31.3	51.8	64.0	85.0	115.0
DF-38MF50M-40	38 mm	50	40	33.7	55	49.4	62.7	90.4	125.0	165.0
DF-50MF50M-40	50 mm	50	40	45.2	70	65.0	66.3	103.0	125.0	165.0

JIS B 2220 : Pressure Class Rating 10 to 63K, Nominal Flange Sizes DN 15 to 50
Connects JIS flange to fractional or metric tube

Part No.	Tube O.D. D		JIS Flange Size, DN	JIS Class	E	Wrench Flat h	A	l	L	C	F
	in	mm									
DF-4T15A10RF	1/4	6.35	15	10K	4.82	23.81	15.24	34.79	42.16	70.10	94.99
DF-6T15A10RF	3/8	9.52	15	10K	7.11	23.81	16.76	36.32	43.68	70.10	94.99
DF-8T15A10RF	1/2	12.7	15	10K	10.41	23.81	22.86	36.32	46.48	70.10	94.99
DF-12T15A10RF	3/4	19.05	15	10K	15.74	31.75	24.38	38.35	48.51	70.10	94.99
DF-16T25A10RF	1	25.4	25	10K	22.35	34.91	31.24	48.76	60.96	89.91	124.96
DF-32T50A10RF	2	50.8	50	10K	45.97	69.85	67.56	64.51	101.85	119.88	154.94
DF-12M15A10FF	12 mm		15	10K	9.5	20	22.8	36.3	46.5	70.0	95.0
DF-18M15A10RF	18 mm		15	10K	15.1	32	24.4	38.4	48.5	70.0	95.0
DF-25M25A10RF	25 mm		25	10K	21.8	35	31.3	48.8	61.0	90.0	125.0

Lab Joint Flange Connector DLJ

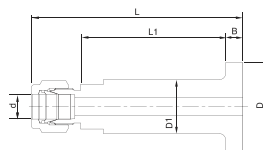

Connects Flange to fractional tube

Part No.	Tube O.D.		Dimension					
	in	mm	L	L ₁	l	D	D ₁	d min
Serrated Seal Face Flange								
DLJ-4T8F-SR-S	1/4	6.35	80.8	56.5	6.5	35	22.2	4.8
DLJ-6T8F-SR-S	3/8	9.52	82.3	56.5	6.5	35	22.2	7.1
DLJ-8T8F-SR-S	1/2	12.70	84.8	56.5	6.5	35	22.2	10.4
Smooth Seal Face Flange								
DLJ-4T8F-SM-S	1/4	6.35	80.8	56.5	6.5	35	22.2	4.8
DLJ-6T8F-SM-S	3/8	9.52	82.3	56.5	6.5	35	22.2	7.1
DLJ-8T8F-SM-S	1/2	12.70	84.8	56.5	6.5	35	22.2	10.4

Installation

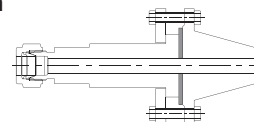

Lap joint flange connector installation with slip-on and welding neck flanges, using sealing gasket on the flange seal face.

Lap joint flange connector is designed to connect process flange to instrument. Dk-Lok port is constructed integrally out of ANSI B16.5 Class 2500 flange. "Smooth" and "Concentric Serrated" flange seal face are available. External groove is provided to identify the serrated face.

Flange Seal Face



● External Groove
Concentric Serrated : SR
Seal Face Roughness :
Ra 6.3 to 12.5 Micrometer



Smooth : SM
Seal Face Roughness :
Ra 3.2 to 6.3 Micrometer

Dk-Lok Tube Fittings

AN Union DUA

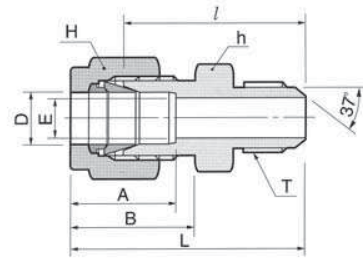
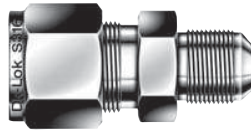

Connects fractional tube to AN flared tube

Part No.	Tube O.D. D		AN Tube Flare Size		Straight Thread T(U)	E Min.	Width across flat				A	B	l	L
	in	mm	in	mm			h	H	in	mm				
DUA 1-2	1/16	1.59	1/8	3.17	5/16-24	1.27	7/16	11.11	5/16	7.93	8.63	10.92	23.36	27.17
DUA 2-2	1/8	3.17	1/8	3.17	5/16-24	1.52	7/16	11.11	7/16	11.11	12.70	15.24	24.89	31.49
DUA 2-4	1/8	3.17	1/4	6.35	7/16-20	2.28	1/2	12.70	7/16	11.11	12.70	15.24	28.44	35.05
DUA 4-4	1/4	6.35	1/4	6.35	7/16-20	4.31	1/2	12.70	9/16	14.28	15.24	17.78	30.22	37.59
DUA 5-5	5/16	7.93	5/16	7.93	1/2-20	5.84	9/16	14.28	5/8	15.87	16.25	18.54	30.98	38.35
DUA 6-4	3/8	9.52	1/4	6.35	7/16-20	4.31	5/8	15.87	11/16	17.46	16.76	19.30	32.25	39.62
DUA 6-6	3/8	9.52	3/8	9.52	9/16-18	7.11	5/8	15.87	11/16	17.46	16.76	19.30	32.25	39.62
DUA 8-8	1/2	12.70	1/2	12.70	3/4-16	9.90	13/16	20.64	7/8	22.22	22.86	21.84	35.81	45.97
DUA 12-12	3/4	19.05	3/4	19.05	1-1/16-12	15.49	1-1/8	28.58	1-1/8	28.58	24.38	21.84	43.18	53.34
DUA 16-16	1	25.40	1	25.40	1-5/16-12	21.33	1-3/8	34.92	1-1/2	38.10	31.24	26.41	49.27	61.46
DUA 20-20	1-1/4	31.75	1-1/4	31.75	1-5/8-12	27.68	1-3/4	44.45	1-7/8	47.63	41.14	38.86	55.46	77.56
DUA 24-24	1-1/2	38.10	1-1/2	38.10	1-7/8-12	34.03	2-1/8	53.97	2-1/4	57.15	50.03	45.21	63.07	90.25
DUA 32-32	2	50.80	2	50.80	2-1/2-12	45.97	2-3/4	69.85	3	76.20	67.56	62.73	83.24	120.57

Dk-Lok AN fitting 37° Flare is designed to SAE J514 standard. AN fittings are used normally in Army and Navy instrumentation.

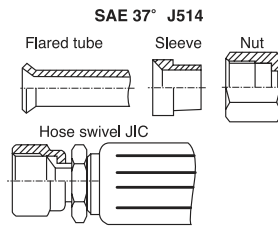
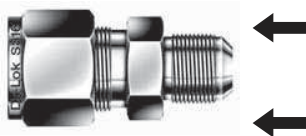

AN Bulkhead Union DUBA

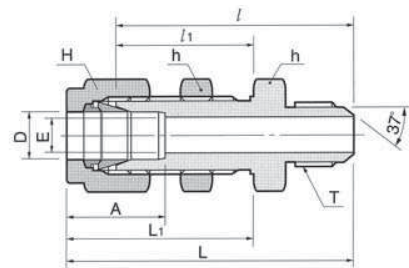
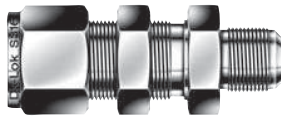

Connects fractional tube to AN flared tube

Part No.	Tube O.D. D		AN Tube Flare Size		Straight Thread T(U)	E Min.	Width across flat				A	l	l ₁	L	L ₁	Panel Hole Drill Size	Panel Max Thickness
	in	mm	in	mm			h	H	in	mm							
DUBA 2-2	1/8	3.17	1/8	3.17	5/16-24	1.77	1/2	12.70	7/16	11.11	13.71	40.85	24.63	47.45	31.23	8.33	12.70
DUBA 4-4	1/4	6.35	1/4	6.35	7/16-20	4.31	5/8	15.87	9/16	14.28	15.24	46.48	26.16	53.84	33.52	11.50	10.16
DUBA 6-6	3/8	9.52	3/8	9.52	9/16-18	7.11	3/4	19.05	11/16	17.46	16.76	49.78	29.46	57.15	36.83	14.68	11.17
DUBA 8-8	1/2	12.70	1/2	12.70	3/4-16	9.90	5/16	23.81	7/8	22.22	22.86	55.62	31.75	65.78	41.91	19.44	12.70
DUBA 12-12	3/4	19.05	3/4	19.05	1-1/16-12	15.49	1-3/16	30.16	1-1/8	28.58	24.38	68.83	37.33	78.99	47.49	25.79	16.76
DUBA 16-16	1	25.40	1	25.40	1-5/16-12	21.33	1-5/8	41.27	1-1/2	38.10	31.24	80.26	45.21	92.45	57.40	33.73	19.05
DUBA 20-20	1-1/4	31.75	1-1/4	31.75	1-5/8-12	27.68	1-7/8	47.63	1-7/8	47.63	41.14	86.37	47.75	108.47	69.85	41.67	19.05
DUBA 24-24	1-1/2	38.10	1-1/2	38.10	1-7/8-12	34.03	2-1/4	57.15	2-1/4	57.15	50.03	94.33	49.27	121.51	76.45	49.61	19.05
DUBA 32-32	2	50.80	2	50.80	2-1/2-12	45.97	2-3/4	69.85	3	76.20	67.56	114.29	56.38	151.62	93.71	16.27	19.05

Male AN Adapter DMAA

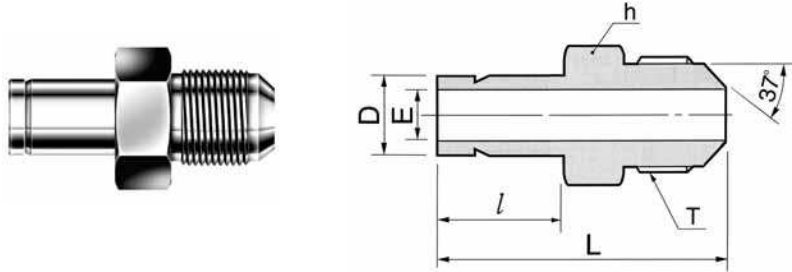

Connects fractional Dk-Lok port to AN flared tube

Part No.	Tube O.D. D		AN Tube Flare Size		Straight Thread T(U)	E Min.	Width across flat h		l	L
	in	mm	in	mm			in	mm		
DMAA 4-4	1/4	6.35	1/4	6.35	7/16-20	4.57	1/2	12.7	15.75	37.1
DMAA 6-6	3/8	9.52	3/8	9.52	9/16-18	7.11	5/8	15.87	17.5	39.63
DMAA 8-6	1/2	12.70	3/8	9.52	9/16-18	7.11	5/8	15.87	23.1	45.7
DMAA 8-8	1/2	12.70	1/2	12.70	3/4-16	9.9	13/16	20.64	23.1	48.52
DMAA 8-10	1/2	12.70	5/8	15.87	7/8-14	9.9	15/16	23.81	23.1	52.0
DMAA 10-10	5/8	15.87	5/8	15.87	7/8-14	12.3	15/16	23.81	27.68	56.13
DMAA 12-12	3/4	19.05	3/4	19.05	1-1/16-12	14.98	1-1/8	28.57	24.7	56.13
DMAA 16-16	1	25.4	1	25.4	1-5/16-12	20.06	1-3/8	34.92	31.7	65.33

AN Adapter DAA

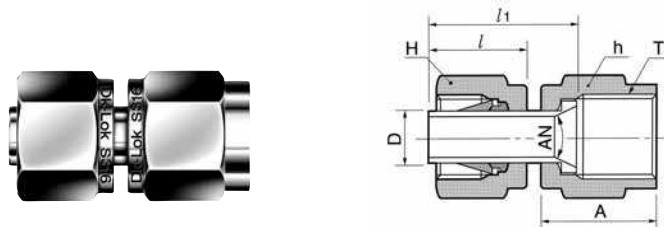

Connects fractional Dk-Lok port tube to AN male

Part No.	Tube O.D. D		AN Tube Flare Size		Straight Thread T(U)	Width across flat				A	l	l ₁
	in	mm	in	mm		h		H				
DAA 2-2	1/8	3.17	1/8	3.17	5/16-24	3/8	9.52	7/16	11.11	13.71	13.46	18.54
DAA 2-4	1/8	3.17	1/4	6.35	7/16-20	9/16	14.28	7/16	11.11	15.74	13.46	19.05
DAA 4-4	1/4	6.35	1/4	6.35	7/16-20	9/16	14.28	9/16	14.28	15.74	15.74	21.33
DAA 6-6	3/8	9.52	3/8	9.52	9/16-18	11/16	17.46	11/16	17.46	18.28	17.52	24.89
DAA 8-8	1/2	12.70	1/2	12.70	3/4-16	7/8	22.22	7/8	22.22	21.59	23.11	31.75

AN adapter is useful to connects Dk-Lok port to SAE JIC 514 37° male Fitting.

Pre-swaged Dk-Lok ferrules on AN adapter needs to follow re-assembly instructions.

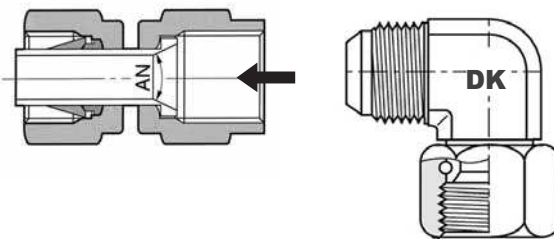

Dk-Lok Tube Fittings

O-Seal Straight Thread Connector (previously DCOS-U) DMC-UO

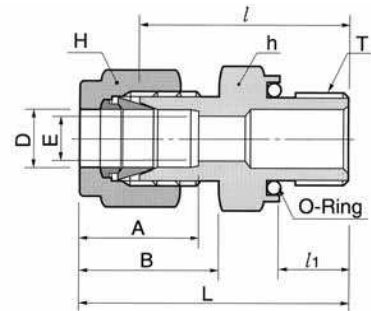

Connects fractional tube to female Straight thread

Part No.	Tube O.D. D		Straight Thread T(U)	E Min.	Width across flat				A	B	l	l ₁	L	O-Ring Uniform Size Number
	in	mm			h	mm	in	mm						
DMC 2-2UO	1/8	3.17	5/16-20	2.28	9/16	14.28	7/16	11.11	12.70	15.24	26.16	8.63	32.76	-011
DMC 3-3UO	3/16	4.76	3/8-24	3.04	5/8	15.87	1/2	12.70	13.71	16.00	27.68	9.65	34.29	-012
DMC 4-4UO	1/4	6.35	7/16-20	4.82	3/4	19.05	9/16	14.28	15.24	17.78	30.98	10.41	38.35	-013
DMC 5-5UO	5/16	7.93	1/2-20	6.35	7/8	22.22	5/8	15.87	16.25	18.54	33.27	11.17	40.64	-112
DMC 6-6UO	3/8	9.52	9/16-18	7.11	15/16	23.81	11/16	17.46	16.76	19.30	35.05	11.93	42.41	-113
DMC 8-8UO	1/2	12.70	3/4-16	10.41	1-1/8	28.57	7/8	22.22	22.86	21.84	35.81	11.93	45.97	-116
DMC 12-12UO	3/4	19.05	1-1/16-12	15.74	1-1/2	38.10	1-1/8	28.58	24.38	21.84	42.16	14.22	52.32	-121
DMC 16-16UO	1	25.40	1-5/16-12	22.35	1-3/4	44.45	1-1/2	38.10	31.24	26.41	45.97	14.22	58.16	-125

O-Seal Pipe Thread Connector (previously DCOP) DMC-NO

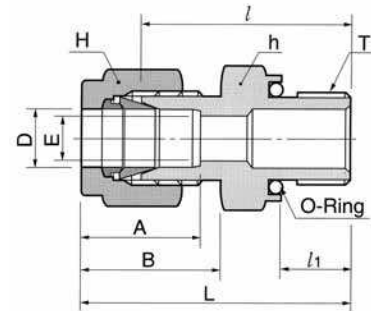
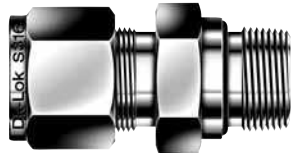

Connects fractional tube to female NPT thread

Part No.	Tube O.D. D		T *(NPT)	E Min.	Width across flat				A	B	l	l ₁	L	O-Ring Uniform Size Number
	in	mm			h	mm	in	mm						
DMC 2-2NO	1/8	3.17	1/8	2.28	3/4	19.05	7/16	11.11	12.70	15.24	26.16	7.11	32.76	-013
DMC 4-2NO	1/4	6.35	1/8	4.82	3/4	19.05	9/16	14.28	15.24	17.78	27.68	7.11	35.05	-013
DMC 4-4NO	1/4	6.35	1/4	4.82	15/16	23.81	9/16	14.28	15.24	17.78	30.98	9.65	38.35	-113
DMC 6-4NO	3/8	9.52	1/4	7.11	15/16	23.81	11/16	17.46	16.76	19.30	32.51	9.65	39.87	-113
DMC 6-6NO	3/8	9.52	3/8	7.11	1-1/8	28.58	11/16	17.46	16.76	19.30	34.03	10.41	41.40	-116
DMC 6-8NO	3/8	9.52	1/2	7.11	1-5/16	33.33	11/16	17.46	16.76	19.30	39.62	13.46	46.99	-118
DMC 8-8NO	1/2	12.70	1/2	10.41	1-5/16	33.33	7/8	22.22	22.86	21.84	39.62	13.46	49.78	-118

Installation Instructions

O-seal Connectors

1. Lubricate O-ring with a lubricant compatible with the O-ring material and the system fluid.
2. Finger-tighten the O-seal connector into the female port.
3. Hand-tighten until the O-ring squeezing on the face of the female port is felt.
4. Tighten slightly further with a wrench to completely compress the O-ring
 - Keep the O-seal body still during connecting or disconnecting.

**Non-Positionable
SAE Male Connector
DMCS-U**

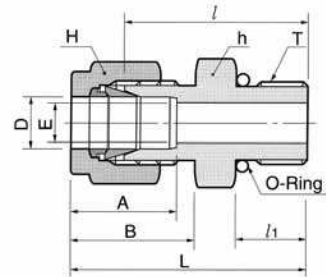

Connects fractional tube to SAE straight thread boss

Part No.	Tube O.D. D		Straight Thread T(U)	E Min.	Width across flat				A	B	l	l ₁	L	O-Ring Uniform Size Number
	in	mm			h	H	in	mm						
DMCS 2-2U	1/8	3.17	5/16-24	2.28	7/16	11.11	7/16	11.11	12.70	15.24	23.26	7.62	29.97	-902
DMCS 4-4U	1/4	6.35	7/16-20	4.82	9/16	14.28	9/16	14.28	15.24	17.78	26.67	9.14	34.03	-904
DMCS 4-6U	1/4	6.35	9/16-18	4.82	11/16	17.46	9/16	14.28	15.24	17.78	28.19	9.90	35.56	-906
DMCS 4-8U	1/4	6.35	3/4-16	4.82	7/8	22.22	9/16	14.28	15.24	17.78	30.22	11.17	37.59	-908
DMCS 4-10U	1/4	6.35	7/8-14	4.82	1	25.40	9/16	14.28	15.24	17.78	33.27	12.70	40.64	-910
DMCS 5-5U	5/16	7.93	1/2-20	5.84	5/8	15.87	5/8	15.87	16.25	18.54	27.43	9.14	34.79	-905
DMCS 6-4U	3/8	9.52	7/16-20	5.08	5/8	15.87	11/16	17.46	16.76	19.30	28.19	9.14	35.56	-904
DMCS 6-6U	3/8	9.52	9/16-18	7.11	11/16	17.46	11/16	17.46	16.76	19.30	29.71	9.90	37.08	-906
DMCS 6-8U	3/8	9.52	3/4-16	7.11	7/8	22.22	11/16	17.46	16.76	19.30	31.75	11.17	39.11	-908
DMCS 6-10U	3/8	9.52	7/8-14	7.11	1	25.40	11/16	17.46	16.76	19.30	34.79	12.70	42.16	-910
DMCS 8-6U	1/2	12.70	9/16-18	7.11	13/16	20.64	7/8	22.22	22.86	21.84	28.95	9.90	39.11	-906
DMCS 8-8U	1/2	12.70	3/4-16	10.41	7/8	22.22	7/8	22.22	22.86	21.84	31.75	11.17	41.91	-908
DMCS 8-10U	1/2	12.70	7/8-14	10.41	1	25.40	7/8	22.22	22.86	21.84	34.79	12.70	44.95	-910
DMCS 8-12U	1/2	12.70	1-1/16-12	10.41	1-1/4	31.75	7/8	22.22	22.86	21.84	38.86	14.98	49.02	-912
DMCS 10-8U	5/8	15.87	3/4-16	10.66	15/16	23.81	1	25.40	24.38	21.84	31.75	11.17	41.91	-908
DMCS 10-10U	5/8	15.87	7/8-14	12.70	1	25.40	1	25.40	24.38	21.84	35.05	12.70	45.21	-910
DMCS 12-8U	3/4	19.05	3/4-16	10.66	1-1/16	26.98	1-1/8	28.57	24.38	21.84	35.81	11.17	45.97	-908
DMCS 12-12U	3/4	19.05	1-1/16-12	15.74	1-1/4	31.75	1-1/8	28.57	24.38	21.84	38.86	14.98	49.02	-912
DMCS 14-14U	7/8	22.22	1-3/16-12	18.28	1-3/8	34.92	1-1/4	31.75	25.90	21.84	38.86	14.98	49.02	-914
DMCS 16-12U	1	25.40	1-1/16-12	16.76	1-3/8	34.92	1-1/2	38.10	31.24	26.41	41.14	14.98	53.34	-912
DMCS 16-16U	1	25.40	1-5/16-12	22.35	1-1/2	38.10	1-1/2	38.10	31.24	26.41	42.16	14.98	54.35	-916
DMCS 20-20U	1-1/4	31.75	1-5/8-12	27.68	1-7/8	47.63	1-7/8	47.63	41.14	38.86	46.22	14.98	68.32	-920
DMCS 24-24U	1-1/2	38.10	1-7/8-12	34.03	2-1/8	53.98	2-1/4	57.15	50.03	45.21	50.54	14.98	77.72	-924
DMCS 32-32U	2	50.80	2-1/2-12	45.97	2-3/4	69.85	3	76.20	67.56	62.73	64.26	14.98	101.60	-932

Connects metric tube to SAE straight thread boss

Part No.	Tube O.D. D		Straight Thread T(U)	E Min.	Width across flat		A	B	l	l ₁	L	O-Ring Uniform Size Number
	in	mm			h	H						
DMCS 6M-6U		6	9/16-18	4.8	18	14	15.3	17.7	28.2	9.90	36.5	-906
DMCS 10M-6U		10	9/16-18	7.9	18	19	17.2	19.5	29.7	9.90	37.3	-906
DMCS 10M-8U		10	3/4-16	7.9	22	19	17.2	19.5	31.8	11.17	39.4	-908
DMCS 12M-4U		12	7/16-20	5.2	22	22	22.8	22.0	28.2	9.14	38.3	-904
DMCS 12M-6U		12	9/16-18	7.5	22	22	22.8	22.0	29.0	9.90	39.1	-906

Dk-Lok Tube Fittings

Positionable SAE Male Elbow DLS-UP

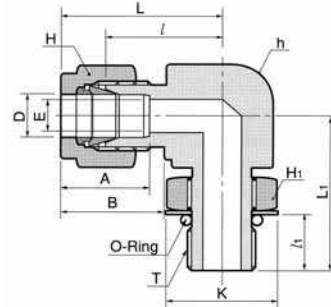

Connects fractional tube to SAE straight thread boss

Part No.	Tube O.D. D		Straight Thread T(U)	E Min.	Width across flat						A	B	l	l ₁	L	L ₁	K	O-Ring Uniform Size Number
	in	mm			h	mm	H	mm	H ₁	mm								
DLS 4-4UP	1/4	6.35	7/16-20	4.82	1/2	12.70	9/16	14.28	9/16	14.28	15.24	17.78	21.08	9.90	28.44	28.44	16.51	-904
DLS 5-5UP	5/16	7.93	1/2-20	5.84	9/16	14.28	5/8	15.87	5/8	15.87	16.25	18.54	22.86	9.90	30.22	29.46	18.28	-905
DLS 6-6UP	3/8	9.52	9/16-18	7.11	5/8	15.87	11/16	17.46	11/16	17.46	16.76	19.30	24.63	11.17	32.00	32.25	20.06	-906
DLS 6-8UP	3/8	9.52	3/4-16	7.11	13/16	20.64	11/16	17.46	7/8	22.22	16.76	19.30	27.43	12.70	34.79	37.84	25.65	-908
DLS 8-8UP	1/2	12.70	3/4-16	10.41	13/16	20.64	7/8	22.22	7/8	22.22	22.86	21.84	27.43	12.70	37.59	37.84	25.65	-908
DLS 10-10UP	5/8	15.87	7/8-14	12.70	1	25.40	1	25.40	1	25.40	24.38	21.84	29.46	14.22	39.62	43.43	29.46	-910
DLS 12-12UP	3/4	19.05	1-1/16-12	15.74	1-1/16	26.98	1-1/8	28.57	1-1/4	31.75	24.38	21.84	31.24	16.76	41.40	48.76	36.57	-912
DLS 14-14UP	7/8	22.22	1-3/16-12	18.28	1-1/4	31.75	1-1/4	31.75	1-3/8	34.92	25.90	21.84	33.02	16.76	43.18	50.54	40.38	-914
DLS 16-16UP	1	25.40	1-5/16-12	22.35	1-3/8	34.92	1-1/2	38.10	1-1/2	38.10	31.24	26.41	38.35	16.76	50.54	53.59	43.94	-916
DLS 20-20UP	1-1/4	31.75	1-5/8-12	27.68	1-11/16	42.76	1-7/8	47.63	1-7/8	47.63	41.14	38.86	45.72	16.76	67.81	58.16	54.86	-920
DLS 24-24UP	1-1/2	38.10	1-7/8-12	34.03	2	50.80	2-1/4	57.15	2-1/8	53.98	50.03	45.21	50.80	16.76	77.97	60.45	62.23	-924
DLS 32-32UP	2	50.80	2-1/2-12	45.97	2-3/4	69.85	3	76.20	2-3/4	69.85	67.56	62.73	69.85	16.76	107.18	71.62	80.26	-932

Installation Instructions

SAE and ISO parallel Thread Fittings

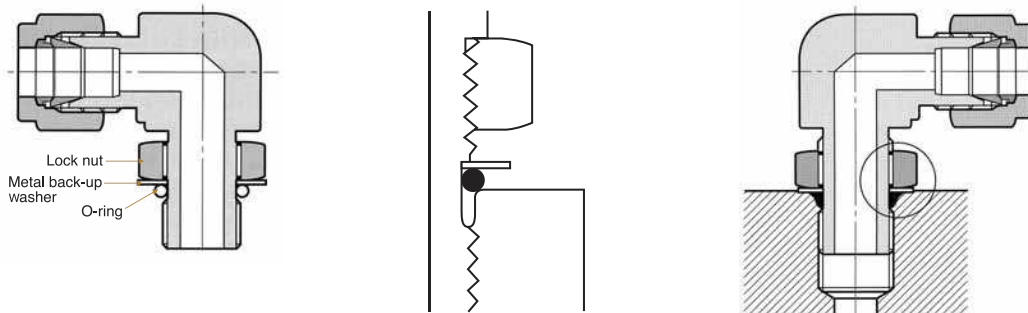

1. Lubricate O-ring with a lubricant compatible with the O-ring material and the system fluid.
2. Back the locknut out.
3. Finger-tighten the fitting into the straight thread boss until the metal backup washer contacts the face of the boss.
4. Position the fitting by backing it out until the fitting end is positioned in the desired direction.
 - No more than one turn backing out.
5. Hold the fitting in the direction and wrench-tighten the locknut until the washer contacts the face of the boss.

**Positionable
45° SAE Male Elbow
(previously DLBS-U)
DLBS-UP**

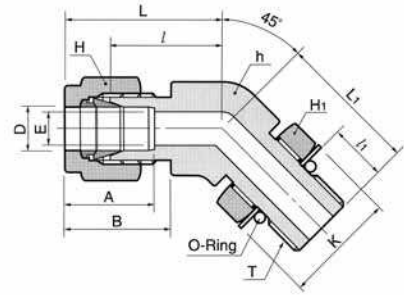

Connects fractional tube to SAE straight thread boss

Part No.	Tube O.D. D		Straight Thread T(U)	E Min.	Width across flat						A	B	l	l ₁	L	L ₁	K	O-Ring Uniform Size Number
	in	mm			h	mm	H	mm	H ₁	mm								
DLBS 4-4UP	1/4	6.35	7/16-20	4.82	1/2	12.70	9/16	14.28	9/16	14.28	15.24	17.78	18.28	9.90	25.65	25.65	16.51	-904
DLBS 6-6UP	3/8	9.52	9/16-18	7.11	5/8	15.87	11/16	17.46	11/16	17.46	16.76	19.30	20.57	11.17	27.94	28.19	20.06	-906
DLBS 8-8UP	1/2	12.70	3/4-16	10.41	13/16	20.64	7/8	22.22	7/8	22.22	22.86	21.84	21.84	12.70	32.00	32.25	25.65	-908
DLBS12-12UP	3/4	19.05	1-1/16-12	15.74	1-1/8	28.58	1-1/8	28.58	1-1/4	31.75	24.38	21.84	29.71	16.76	39.87	47.24	36.57	-912
DLBS16-16UP	1	25.40	1-5/16-12	22.35	1-3/8	34.92	1-1/2	38.10	1-1/2	38.10	31.24	26.41	35.30	16.76	47.49	50.54	43.94	-916

**Positionable
SAE Male Run Tee
(previously DTRS-U)
DTRS-UP**

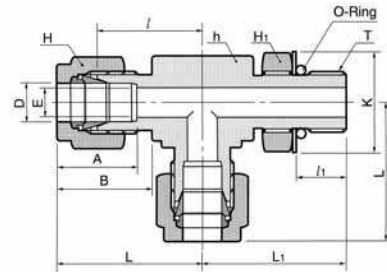

Connects fractional tube to SAE straight thread boss

Part No.	Tube O.D. D		Straight Thread T(U)	E Min.	Width across flat						A	B	l	l ₁	L	L ₁	K	O-Ring Uniform Size Number
	in	mm			h	mm	H	mm	H ₁	mm								
DTRS 4-4UP	1/4	6.35	7/16-20	4.82	1/2	12.70	9/16	14.28	9/16	14.28	15.24	17.78	21.08	9.90	28.44	28.44	16.51	-904
DTRS 6-6UP	3/8	9.52	9/16-18	7.11	5/8	15.87	11/16	17.46	11/16	17.46	16.76	19.30	24.63	11.17	32.00	32.25	20.06	-906
DTRS 8-8UP	1/2	12.70	3/4-16	10.41	13/16	20.64	7/8	22.22	7/8	22.22	22.86	21.84	27.43	12.70	37.59	37.84	25.65	-908
DTRS 12-12UP	3/4	19.05	1-1/16-12	15.74	1-1/8	26.98	1-1/8	28.58	1-1/4	31.75	24.38	21.84	31.24	16.76	41.40	48.76	36.57	-912
DTRS 16-16UP	1	25.40	1-5/16-12	22.35	1-3/8	34.92	1-1/2	38.10	1-1/2	38.10	31.24	26.41	38.35	16.76	50.54	50.54	43.94	-916
DTRS 20-20UP	1-1/4	31.75	1-5/8-12	27.68	1-11/16	42.86	1-7/8	47.63	1-7/8	47.63	41.14	38.86	45.72	16.76	67.81	58.16	54.86	-920
DTRS 24-24UP	1-1/2	38.10	1-7/8-12	34.03	2	50.80	2-1/4	57.15	2-1/8	53.98	50.03	45.21	50.80	16.76	77.97	60.45	62.23	-924
DTRS 32-32UP	2	50.80	2-1/2-12	45.97	2-3/4	69.85	3	76.20	2-3/4	69.85	67.56	62.73	69.85	16.76	107.18	71.62	80.26	-932

**Positionable
SAE Male Branch Tee
(previously DTBS-U)
DTBS-UP**

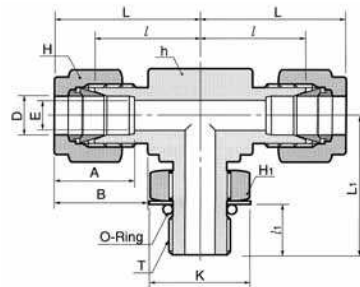

Connects fractional tube to SAE straight thread boss

Part No.	Tube O.D. D		Straight Thread T(U)	E Min.	Width across flat						A	B	l	l ₁	L	L ₁	K	O-Ring Uniform Size Number
	in	mm			h	mm	H	mm	H ₁	mm								
DTBS 4-4UP	1/4	6.35	7/16-20	4.82	1/2	12.70	9/16	14.28	9/16	14.28	15.24	17.78	21.08	9.90	28.44	28.44	16.51	-904
DTBS 6-6UP	3/8	9.52	9/16-18	7.11	5/8	15.87	11/16	17.46	11/16	17.46	16.76	19.30	24.63	11.17	32.00	32.25	20.06	-906
DTBS 8-8UP	1/2	12.70	3/4-16	10.41	13/16	20.64	7/8	22.22	7/8	22.22	22.86	21.84	27.43	12.70	37.59	37.84	25.65	-908
DTBS 12-12UP	3/4	19.05	1-1/16-12	15.74	1-1/8	26.98	1-1/8	28.58	1-1/4	31.75	24.38	21.84	31.24	16.76	41.40	48.76	36.57	-912
DTBS 16-16UP	1	25.40	1-5/16-12	22.35	1-3/8	34.92	1-1/2	38.10	1-1/2	38.10	31.24	26.41	38.35	16.76	50.54	53.59	43.94	-916
DTBS 20-20UP	1-1/4	31.75	1-5/8-12	27.68	1-11/16	42.86	1-7/8	47.63	1-7/8	47.63	41.14	38.86	45.72	16.76	67.81	58.16	54.86	-920
DTBS 24-24UP	1-1/2	38.10	1-7/8-12	34.03	2	50.80	2-1/4	57.15	2-1/8	53.98	50.03	45.21	50.80	16.76	77.97	60.45	62.23	-924
DTBS 32-32UP	2	50.80	2-1/2-12	45.97	2-3/4	69.85	3	76.20	2-3/4	69.85	67.56	62.73	69.85	16.76	107.18	71.62	80.26	-932

Dk-Lok Tube Fittings

Positionable
Male Elbow
ISO Parallel Thread
DLM-GP

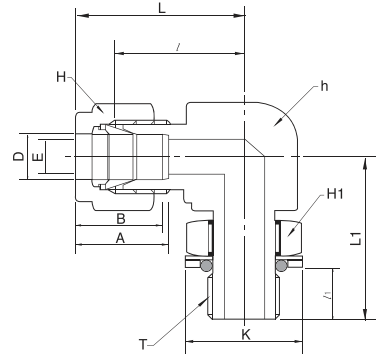

Connects fractional tube to ISO parallel thread

Part No.	Tube O.D. D		T G(PF)	E Min.	Width across flat						A	B	l	l ₁	L	L ₁	K	O-Ring Uniform Size Number
	in	mm			h		H		H ₁									
					in	mm	in	mm	in	mm								
DLM 4-2GP	1/4	6.35	1/8	4.06	1/2	12.70	9/16	14.28	9/16	14.28	15.24	17.78	19.6	8.12	26.92	26.42	17.27	P8
DLM 4-4GP	1/4	6.35	1/4	4.82	5/8	15.87	11/16	17.46	3/4	19.05	15.24	17.78	21.6	9.14	28.95	32.30	22.86	-111
DLM 6-4GP	3/8	9.52	1/4	5.84	5/8	15.87	11/16	17.46	3/4	19.05	16.76	19.30	23.1	9.14	30.48	32.30	22.86	-111
DLM 6-6GP	3/8	9.52	3/8	7.11	13/16	20.64	11/16	17.46	3/4	19.05	16.76	19.30	25.9	9.39	33.27	37.10	26.41	-113
DLM 8-4GP	1/2	12.70	1/4	5.84	13/16	20.64	7/8	22.22	7/8	22.22	22.86	21.84	25.9	9.14	36.06	35.10	22.86	-111
DLM 8-6GP	1/2	12.70	3/8	7.87	13/16	20.64	7/8	22.22	7/8	22.22	22.86	21.84	25.9	9.39	36.06	37.10	26.41	-113
DLM 8-8GP	1/2	12.70	1/2	10.41	15/16	23.81	7/8	22.22	1-1/16	26.98	22.86	21.84	27.9	12.95	38.10	43.40	32.00	P18
DLM 12-8GP	3/4	19.05	1/2	11.93	1-1/16	26.98	1-1/8	28.57	1-1/16	26.98	24.38	21.84	29.7	12.95	39.87	45.21	32.00	P18
DLM 12-12GP	3/4	19.05	3/4	15.74	1-1/16	26.98	1-1/8	28.57	1-3/8	34.92	24.38	21.84	29.7	12.95	39.87	48.77	41.14	-119
DLM 16-16GP	1	25.40	1	19.81	1-3/8	34.92	1-1/2	38.10	1-5/8	41.28	31.24	26.41	36.8	13.97	49.02	53.60	48.51	-217

Connects metric tube to ISO parallel thread

Part No.	Tube O.D. D		T G(PF)	E Min.	Width across flat						A	B	l	l ₁	L	L ₁	K	O-Ring Uniform Size Number
	in	mm			h		H		H ₁									
					in	mm	in	mm	in	mm								
DLM 6M-2GP		6	1/8	4.0	12.7	14	14.28	15.3	17.7	19.6	8.1	27.0	26.4	17.3	P8			
DLM 6M-4GP		6	1/4	4.8	15.8	14	19.05	15.3	17.7	21.6	9.1	29.0	32.3	22.9	-111			
DLM 6M-6GP		6	3/8	4.8	20.6	14	22.22	15.3	17.7	24.4	9.4	31.8	37.1	26.4	-113			
DLM 8M-2GP		8	1/8	4.0	14.2	16	14.28	16.2	18.6	21.3	8.1	28.8	27.4	17.3	P8			
DLM 8M-4GP		8	1/4	5.9	15.8	16	19.05	16.2	18.6	22.4	9.1	29.9	32.2	22.9	-111			
DLM 10M-4GP		10	1/4	5.9	20.6	19	19.05	17.2	19.5	25.9	9.1	33.5	35.0	22.9	-113			
DLM 10M-6GP		10	3/8	7.9	20.6	19	22.22	17.2	19.5	25.9	9.4	33.5	37.1	26.4	-111			
DLM 12M-4GP		12	1/4	5.9	20.6	22	19.05	22.8	22.0	25.9	9.1	36.0	35.0	22.9	-113			
DLM 12M-6GP		12	3/8	7.9	20.6	22	22.22	22.8	22.0	25.9	9.4	36.0	37.1	26.4	-113			
DLM 12M-8GP		12	1/2	9.5	23.8	22	26.98	22.8	22.0	27.9	13.0	38.0	43.4	32.0	P18			

Male Pipe Weld Connector DCW

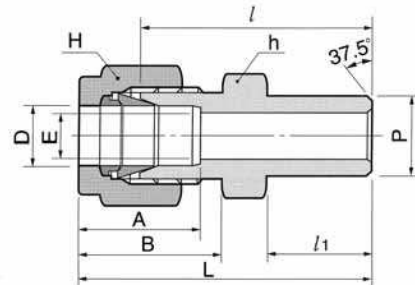
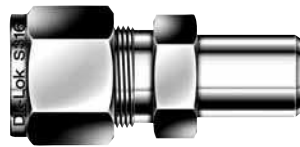

Connects fractional tube to pipe

Part No.	Tube O.D.		Male Pipe Size		E Min.	Width across flat				A	B	l	l ₁	L
	D		P			h		H						
	in	mm	Nom.	O.D.		in	mm	in	mm					
DCW 2-2P	1/8	3.17	1/8	10.29	2.28	7/16	11.11	7/16	11.11	12.70	15.24	23.87	9.65	31.24
DCW 3-2P	3/16	4.76	1/8	10.29	3.04	7/16	11.11	1/2	12.70	13.71	16.00	24.63	9.65	31.24
DCW 4-2P	1/4	6.35	1/8	10.29	4.82	1/2	12.70	9/16	14.28	15.24	17.78	25.40	9.65	32.76
DCW 4-4P	1/4	6.35	1/4	13.72	4.82	9/16	14.28	9/16	14.28	15.24	17.78	30.48	14.22	37.84
DCW 5-2P	5/16	7.93	1/8	10.29	5.08	9/16	14.28	5/8	15.87	16.25	18.54	26.67	9.65	34.03
DCW 5-4P	5/16	7.93	1/4	13.72	6.35	9/16	14.28	5/8	15.87	16.25	18.54	31.24	14.22	38.60
DCW 6-4P	3/8	9.52	1/4	13.72	7.11	5/8	15.87	11/16	17.46	16.76	19.30	32.51	14.22	39.87
DCW 6-6P	3/8	9.52	3/8	17.15	7.11	11/16	17.46	11/16	17.46	16.76	19.30	32.51	14.22	39.87
DCW 6-8P	3/8	9.52	1/2	21.34	7.11	7/8	22.22	11/16	17.46	16.76	19.30	38.86	11.05	43.23
DCW 8-6P	1/2	12.70	3/8	17.15	10.41	13/16	20.64	7/8	22.22	22.86	21.84	33.27	14.22	43.43
DCW 8-8P	1/2	12.70	1/2	21.34	10.41	7/8	22.22	7/8	22.22	22.86	21.84	38.86	19.05	49.02
DCW 8-12P	1/2	12.70	3/4	26.67	10.41	1-1/16	26.98	7/8	22.22	22.86	21.84	40.38	19.05	50.54
DCW 10-8P	5/8	15.87	1/2	21.34	12.70	15/16	23.81	1	25.40	24.38	21.84	38.86	19.05	49.02
DCW 12-12P	3/4	19.05	3/4	26.67	15.74	1-1/16	26.98	1-1/8	28.58	24.38	21.84	40.38	19.05	50.54
DCW 16-16P	1	25.40	1	33.40	22.35	1-3/8	34.92	1-1/2	38.10	31.24	26.41	50.03	23.87	62.23
DCW 20-20P	1-1/4	31.75	1-1/4	42.16	27.68	1-3/4	44.45	2	50.80	41.14	38.86	55.11	23.87	77.21
DCW 24-24P	1-1/2	38.10	1-1/2	48.26	34.03	2-1/8	53.98	2-1/4	57.15	50.03	45.21	61.72	26.16	88.90
DCW 32-32P	2	50.80	2	60.33	47.75	2-3/4	69.85	3	76.20	67.56	62.73	76.20	26.92	113.53

Connects metric tube to pipe

Part No.	Tube O.D.		Male Pipe Size		E Min.	Width across flat		A	B	l	l ₁	L	
	D		P			h							H
			Nom.	O.D.									
DCW 3M-2P	3		1/8	10.29	2.4	12	12	12.9	15.3	23.1	9.7	29.7	
DCW 4M-2P	4		1/8	10.29	2.4	12	12	13.7	16.1	24.1	9.7	30.7	
DCW 6M-2P	6		1/8	10.29	4.8	14	14	15.3	17.7	25.4	9.7	32.8	
DCW 6M-4P	6		1/4	13.72	4.8	14	14	15.3	17.7	30.2	14.2	37.6	
DCW 8M-2P	8		1/8	10.29	5.1	15	16	16.2	18.6	26.7	9.7	34.2	
DCW 8M-4P	8		1/4	13.72	6.4	15	16	16.2	18.6	31.2	14.2	38.7	
DCW 8M-8P	8		1/2	21.34	6.4	22	16	16.2	18.6	37.3	19.0	44.8	
DCW 10M-4P	10		1/4	13.72	7.1	18	19	17.2	19.5	33.3	14.2	40.9	
DCW 10M-6P	10		3/8	17.15	7.9	18	19	17.2	19.5	32.5	14.2	40.1	
DCW 10M-8P	10		1/2	21.34	7.9	22	19	17.2	19.5	38.1	19.0	45.7	
DCW 12M-4P	12		1/4	13.72	7.1	22	22	22.8	22.0	33.3	14.2	43.4	
DCW 12M-6P	12		3/8	17.15	9.5	22	22	22.8	22.0	33.3	14.2	43.4	
DCW 12M-8P	12		1/2	21.34	9.5	22	22	22.8	22.0	38.1	19.0	48.2	
DCW 14M-6P	14		3/8	17.15	10.3	24	25	24.4	22.0	34.0	14.2	44.1	
DCW 15M-8P	15		1/2	21.34	11.9	24	25	24.4	22.0	38.9	19.0	49.0	
DCW 16M-8P	16		1/2	21.34	12.7	24	25	24.4	22.0	38.9	19.0	49.0	
DCW 18M-8P	18		1/2	21.34	13.5	27	30	24.4	22.0	40.4	19.0	50.5	
DCW 32M-20P	32		1-1/4	42.16	28.6	46	50	42.0	41.6	56.6	23.9	79.6	
DCW 38M-24P	38		1-1/2	48.26	33.7	55	60	49.4	47.9	64.0	26.2	91.6	

Dk-Lok Tube Fittings

Male Pipe Weld Elbow DLW

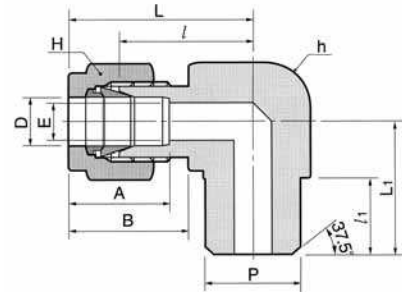
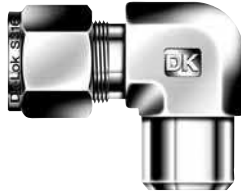

Connects fractional tube to pipe

Part No.	Tube O.D. D		Male Pipe Size P		E Min.	Width across flat				A	B	l	l ₁	L	L ₁
	in	mm	Nom.	O.D.		h	h	H	H						
DLW 2-2P	1/8	3.17	1/8	10.29	4.82	1/2	12.70	9/16	14.28	15.24	17.78	19.55	9.65	26.92	18.79
DLW 4-4P	1/4	6.35	1/4	13.72	4.82	1/2	12.70	9/16	14.28	15.24	17.78	19.55	14.22	26.92	23.36
DLW 6-4P	3/8	9.52	1/4	13.72	7.11	5/8	15.87	11/16	17.46	16.76	19.30	23.11	14.22	30.48	25.40
DLW 8-8P	1/2	12.70	1/2	21.34	10.41	13/16	20.64	7/8	22.22	22.86	21.84	25.90	19.05	36.06	33.02
DLW 12-12P	3/4	19.05	3/4	26.67	15.74	1-1/16	26.98	1-1/8	28.58	24.38	21.84	29.71	19.05	39.87	36.83

Tube Socket Weld Connector DCSW

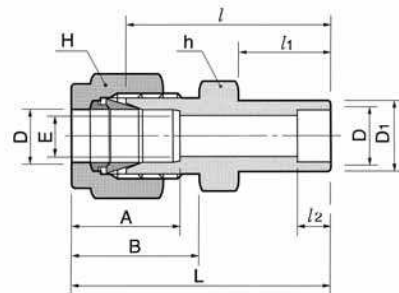
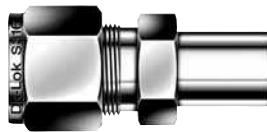

Connects fractional tubes

Part No.	Tube O.D. D		E Min.	D ₁	Width across flat				A	B	l	l ₁	l ₂	L
	in	mm			h	h	H	H						
DCSW 2-2	1/8	3.17	2.28	7.87	7/16	11.11	7/16	11.11	12.70	15.24	22.35	8.63	6.35	28.95
DCSW 4-4	1/4	6.35	4.82	11.17	1/2	12.70	9/16	14.28	15.24	17.78	26.16	10.41	7.87	33.52
DCSW 6-6	3/8	9.52	7.11	15.74	5/8	15.87	11/16	17.46	16.76	19.30	30.22	11.93	9.65	37.59
DCSW 8-8	1/2	12.70	10.41	19.05	13/16	20.64	7/8	22.22	22.86	21.84	30.98	11.93	12.70	41.14
DCSW 12-12	3/4	19.05	15.74	26.67	1-1/16	26.98	1-1/8	28.58	24.38	21.84	33.27	11.93	14.22	43.43
DCSW 16-16	1	25.40	22.35	33.27	1-3/8	34.92	1-1/2	38.10	31.24	26.41	40.38	14.22	19.05	52.57

Dk-Lok Welding information

Dk-Lok weld ends are constructed to SCH. 80 or greater.

- Remove the nut and ferrules from the Dk-Lok port.
 - This protects the nut and ferrules from weld heat.
- Cover the Dk-Lok port threads with a protective device such as Dk-Lok Plug (DP).
 - This protects threads and sealing surface on the Dk-Lok port.
 - Finger-tighten the DP to use it many times.
- Tack weld at four positions 90 degree apart.
 - This holds the fitting in alignment and concentricity.
- Complete the welding.
- Remove the protective device and replace the nut and ferrules.

Dk-Lok Tube Fittings

Tube Socket Weld Elbow DLSW

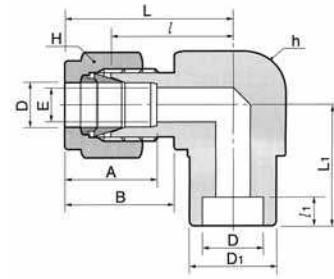

Connects fractional tubes

Part No.	Tube O.D.		E Min.	D ₁	Width across flat				A	B	l	l ₁	L	L ₁
	D				h	H								
	in	mm					in	mm						
DLSW 4-4	1/4	6.35	4.82	12.70	1/2	12.70	9/16	14.28	15.24	17.78	19.55	7.87	26.92	19.55
DLSW 6-6	3/8	9.52	7.11	15.74	5/8	15.87	11/16	17.46	16.76	19.30	23.11	9.65	30.48	23.11
DLSW 8-8	1/2	12.70	10.41	20.57	13/16	20.64	7/8	22.22	22.86	21.84	25.90	12.70	36.06	25.90
DLSW12-12	3/4	19.05	15.74	26.92	1-1/16	26.98	1-1/8	28.58	24.38	21.84	29.71	14.22	39.87	29.71
DLSW16-16	1	25.40	22.35	35.05	1-3/8	34.93	1-1/2	38.10	31.24	26.41	36.83	19.05	49.02	36.83

Welding Bulkhead Union DBUW

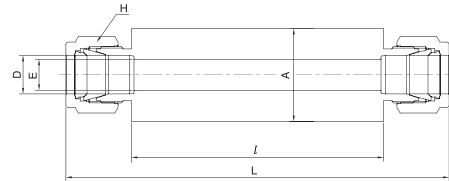

Connects fractional tubes

Part No.	Tube O.D.		E Min.	A Diameter	Width across flat		l	L
	D				H			
	in	mm				in		
DBUW-4	1/4	6.35	4.8	16.0	9/16	14.28	80.0	115.4
DBUW-6	3/8	9.52	7.1	19.0	11/16	17.46	80.0	118.4
DBUW-8	1/2	12.70	10.41	22.0	7/8	22.22	80.0	124.0

Plug DP

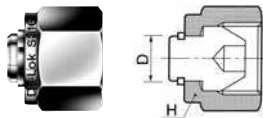

Plugs fractional Dk-Lok port

Part No.	Tube O.D.		Width across flat	
	D		H	
	in	mm	in	mm
DP-1	1/16	1.59	5/16	7.93
DP-2	1/8	3.17	7/16	11.11
DP-3	3/16	4.76	1/2	12.70
DP-4	1/4	6.35	9/16	14.28
DP-5	5/16	7.93	5/8	15.87
DP-6	3/8	9.52	11/16	17.46
DP-8	1/2	12.70	7/8	22.22
DP-10	5/8	15.87	1	25.40
DP-12	3/4	19.05	1-1/8	28.58
DP-14	7/8	22.22	1-1/4	31.75
DP-16	1	25.40	1-1/2	38.10
DP-20	1-1/4	31.75	1-7/8	47.63
DP-24	1-1/2	38.10	2-1/4	57.15
DP-32	2	50.80	3	76.20

Plugs metric Dk-Lok port

Part No.	Tube O.D.	Width across flat
	D	H
DP-2M	2	12
DP-3M	3	12
DP-4M	4	12
DP-6M	6	14
DP-8M	8	16
DP-10M	10	19
DP-12M	12	22
DP-15M	15	25
DP-16M	16	25
DP-18M	18	30
DP-20M	20	32
DP-22M	22	32
DP-25M	25	38
DP-28M	28	46
DP-32M	32	50
DP-38M	38	60

Installation Instructions

Plug is for plugging un-used Dk-Lok port.

1. Remove the nut and ferrules from the Dk-Lok fitting body.
2. Finger-tighten the plug.
3. Tighten the plug 1/4 turn beyond the finger-tight position, keeping the fitting body steady with a backup wrench.
 - Do not tighten 1 1/4 turns as this has machined ferrule not the standard ferrules.
 - Tighten 1/8 turn for 1/16, 1/8, and 3/16 in.; 2, 3, and 4 mm tube Fittings.

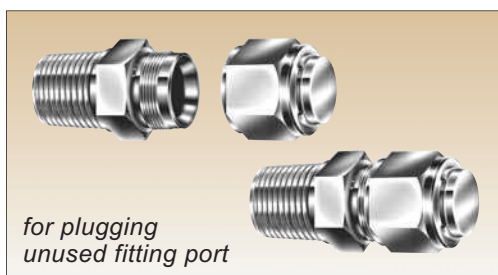

Cap DC

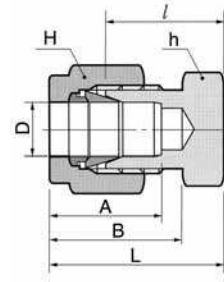

Caps fractional tube end

Part No.	Tube O.D. D		Width across flat				A	B	l	L
	in	mm	h	mm	H	mm				
DC-1	1/16	1.59	5/16	7.93	5/16	7.93	8.63	10.92	11.20	14.18
DC-2	1/8	3.17	7/16	11.11	7/16	11.11	12.70	15.24	13.46	20.06
DC-3	3/16	4.76	7/16	11.11	1/2	12.70	13.71	16.00	14.73	21.33
DC-4	1/4	6.35	1/2	12.70	9/16	14.28	15.24	17.78	16.00	23.26
DC-5	5/16	7.93	9/16	14.28	5/8	15.87	16.25	18.54	17.01	24.38
DC-6	3/8	9.52	5/8	15.87	11/16	17.46	16.76	19.30	18.28	25.65
DC-8	1/2	12.70	13/16	20.63	7/8	22.22	22.86	21.84	19.05	29.21
DC-10	5/8	15.87	15/16	23.81	1	25.40	24.38	21.84	19.81	29.97
DC-12	3/4	19.05	1-1/16	26.98	1-1/8	28.57	24.38	21.84	21.33	31.49
DC-14	7/8	22.22	1-3/16	30.16	1-1/4	31.75	25.90	21.84	23.87	34.03
DC-16	1	25.40	1-3/8	34.92	1-1/2	38.10	31.24	26.41	26.16	38.35
DC-20	1-1/4	31.75	1-3/4	44.45	1-7/8	47.63	41.14	38.86	31.24	53.34
DC-24	1-1/2	38.10	2-1/8	53.98	2-1/4	57.15	50.15	45.21	37.33	64.51
DC-32	2	50.80	2-3/4	69.85	3	76.20	67.56	62.73	49.27	86.61

Caps metric tube ends

Part No.	Tube O.D. D		Width across flat		A	B	l	L
	mm	mm	h	H				
DC-2M	2	12	12	12	12.9	15.3	13.5	20.1
DC-3M	3	12	12	12	12.9	15.3	13.5	20.1
DC-4M	4	12	12	12	13.7	16.1	14.7	21.3
DC-6M	6	14	14	14	15.3	17.7	15.7	23.1
DC-8M	8	15	16	16	16.2	18.6	17.0	24.5
DC-10M	10	18	19	19	17.2	19.5	19.0	26.6
DC-12M	12	22	22	22	22.8	22.0	19.0	29.1
DC-15M	15	24	25	25	24.4	22.0	19.8	29.9
DC-16M	16	24	25	25	24.4	22.0	19.8	29.9
DC-18M	18	27	30	30	24.4	22.0	21.3	31.4
DC-20M	20	30	32	32	26.0	22.0	23.9	34.0
DC-22M	22	30	32	32	26.0	22.0	23.9	34.0
DC-25M	25	35	38	38	31.3	26.5	26.2	38.5
DC-28M	28	41	46	46	36.6	36.6	27.7	48.5
DC-32M	32	46	50	50	42.0	41.6	32.8	55.8
DC-38M	38	55	60	60	49.4	47.9	37.8	65.4

Installation Instructions

Cap

Dk-Lok Cap is for capping tubing end.

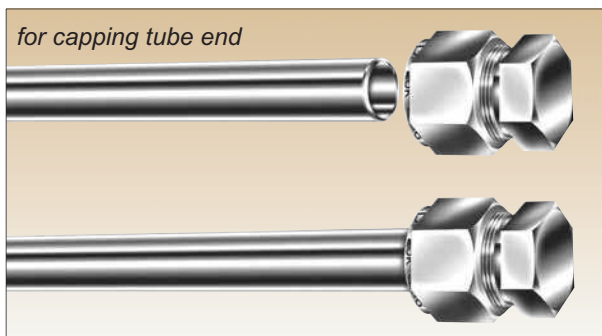

1. Insert tube end into the cap
 - Make sure tube end bottoms on the shoulder of the cap.
2. Finger-tighten the nut
3. Wrench-tighten the nut 1 1/4 turns beyond the finger tight position, keeping the body steady with a backup wrench.
 - Tightens 3/4 turns for 1/16, 1/8, and 3/16 in.; 2,3, and 4mm fittings.
 - For re-use, see re-assembly instruction.

Tube Insert

DI

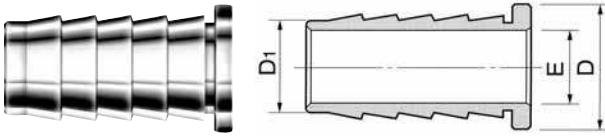

fractional

Part No.	Plastic Tube				E
	D(Tube OD)		D ₁ (Tube ID)		
	in	mm	in	mm	
DI 3-2	3/16	4.76	1/8	3.17	2.28
DI 4-2	1/4	6.35	1/8	3.17	2.28
DI 4-3	1/4	6.35	3/16	4.76	3.55
DI 5-2	5/16	7.93	1/8	3.17	2.28
DI 5-3	5/16	7.93	3/16	4.76	3.04
DI 5-4	5/16	7.93	1/4	6.35	4.82
DI 6-3	3/8	9.52	3/16	4.76	3.04
DI 6-4	3/8	9.52	1/4	6.35	4.82
DI 8-4	1/2	12.7	1/4	6.35	4.82
DI 8-6	1/2	12.7	3/8	9.52	7.87
DI 10-6	5/8	15.87	3/8	9.52	7.87
DI 10-8	5/8	15.87	1/2	12.70	11.17
DI 12-8	3/4	19.05	1/2	12.70	11.17
DI 12-10	3/4	19.05	5/8	15.87	14.22
DI 16-12	1	25.4	3/4	19.05	17.52

Installation Instructions

Tube Insert

for Nylon or Soft Plastic Tubing



Dk-Lok tube insert supports the soft plastic tube internally. This helps the soft tube to connect to Dk-Lok port with no collapse.

1. Fully insert the tube insert into the soft tube end.
2. Insert the soft tube end into the Dk-Lok port.
3. Finger-tighten the nut.
4. Tighten the nut 1 1/4 turns with a wrench, keeping the body steady with a backup wrench.
 - Tighten 3/4 turn for 3/16 in. tube fittings.

metric

Part No.	Plastic Tube		E
	D(Tube OD)	D ₁ (Tube ID)	
DI 6M-4M	6	4	2.8
DI 8M-6M	8	6	4.4
DI 10M-8M	10	8	6.4
DI 12M-8M	12	8	6.4
DI 12M-10M	12	10	8.3

Fuse Plug

DFA

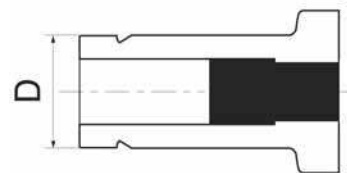

Dk-Lok fuse plug is applicable where heat could initiate fire or an explosive chemical reaction. Fuse plug alloy metal melts or yields at the rated temperature. This is designed to use with Dk-Lok port 3/8 in. OD.

- Maximum applicable instrument pressure: 8 bar (116 psig)

Connects Dk-Lok port 3/8 in. OD

Part No.	Tube O.D.		Temperature Designator	Nominal Temperature Rating
	in	mm		
DFA-6-160-S	3/8	9.52	160	160°F(71°C)
DFA-6-201-S	3/8	9.52	201	201°F(94°C)
DFA-6-255-S	3/8	9.52	255	255°F(124°C)
DFA-6-281-S	3/8	9.52	281	281°F(138°C)

Dk-Lok Tube Fittings

Vent Protector DMD

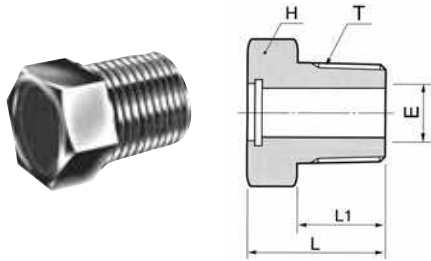

Connects to female NPT thread

Part No.	T NPT	E Min.	H		L	L1
			in	mm		
DMD-4N	1/4	7.11	9/16	15.87	20.57	14.22
DMD-6N	3/8	10.40	11/16	17.46	20.57	14.22
DMD-8N	1/2	12.70	7/8	23.81	26.92	19.05
DMD-12N	3/4	16.00	1-1/16	26.98	28.70	19.05

Construction with bored-through pipe plug and stainless steel 40 x 40 mesh, 0.010 in. diameter.

Dk-Lok vent protector known as bug protector protects foreign particles like insects or debris from entering open ends of instruments or outlet vents.

Calibration Fittings DPCM

DP Transmitter Calibration fittings

Dk-Lok Calibration fitting connects directly to the bleed port of a differential pressure transmitter. This helps simplify the calibration process. Two sizes of threads are available to fit the vent port of Yokogawa/Rosemount, and Honeywell differential pressure transmitters. The conical metal-to-metal sealing face on the straight thread requires no PTFE tape.

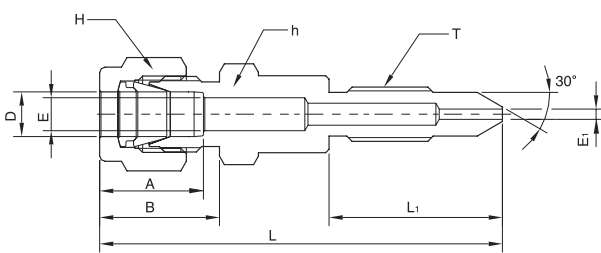

2U thread calibration fitting for
Yokogawa/Rosemount DP transmitters

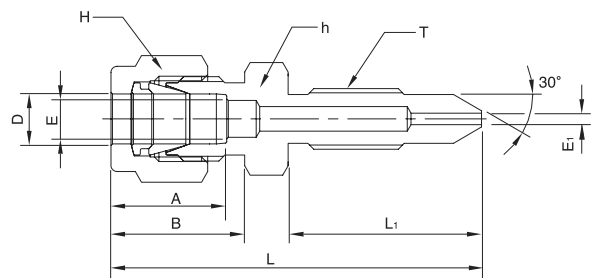

1U thread calibration fitting for
Honeywell DP transmitters

Part No.	Tube O.D. D		Straight Thread T(U)	E	E1 Min.	Width across flat				A	B	L	L1
	in	mm				h		H					
						in	mm	in	mm				
DPCM 4-1U-S	1/4	6.35	1/4-28	4.8	1.5	1/2	12.7	9/16	14.28	15.24	17.78	43.08	19.90
DPCM 4-2U-S	1/4	6.35	5/16-24	4.8	1.5	1/2	12.7	9/16	14.28	15.24	17.78	59.23	35.75

Dielectric Fittings

DEU

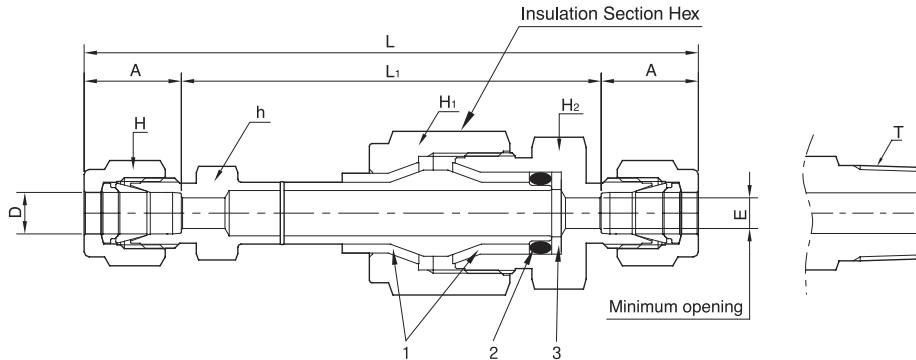

Materials

1. Insulator: Molded Thermoplastic
2. O-ring: 90 Durometer FKM
3. Back Up Ring: Virgin PTFE
- Body, Ferrules, Nuts: Stainless Steel 316

Technical Data

- Pressure Rating: 4,000 psig (275 bar) @ 70°F (21°C)
- Temperature Rating: -40 to 200°F (-40 to 93°C)
- Electrical Resistance at 70°F (21°C): $10 \times 10^6 \Omega$ @ 10 Volts DC, voltage breakdown resistance 3,000 Volts DC.

Part No.	Tube O.D. D		Pipe Thread T(NPT)	E Min		A	L	L ₁	Width across flat							
	in	mm		in	mm				h		H		H ₁		H ₂	
									in	mm	in	mm	in	mm	in	mm
DEU 4	1/4	6.35		0.19	4.8	15.24	95.8	65.3	1/2	12.7	9/16	14.28	7/8	22.22		
DEU 6	3/8	9.52		0.28	7.1	16.76	99.6	65.8	5/8	15.87	11/16	17.46			13/16	20.64
DEU 8	1/2	12.7				22.86	106.0	60.2	13/16		7/8	22.22				
DEU 12M		12.0				22.8	107.0	61.7		22		22				22
DEMC 6-4N	3/8	9.52	1/4					16.76	94.7	-	5/8	15.87	11/16	17.46	7/8	22.22

Di-electric tube fitting is designed to apply where electrical current flowing through a pipe or tubing line must be interrupted to protect instruments.

Di-electric Tube fitting is commonly used in the natural gas transmission station where installed on impulse lines ahead of stations. This fitting interrupts cathodic current flow while permitting full fluid flow.

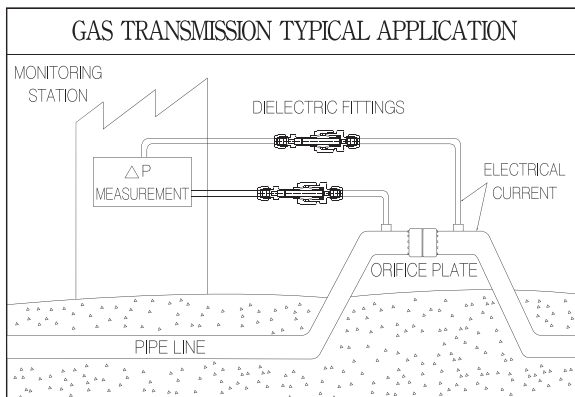

Function

- The insulation function is performed by thermoplastic insulators.
- FKM O-ring and PTFE back up ring provide fluid containment function within the fitting.
- Dk-Lok twin ferrule system provides reliable sealing in the impulse line tubing.

Caution



CAUTION
DO NOT WRENCH THIS HEX
NOR DISASSEMBLE THIS CONNECTION

This "NO wrenching label" is placed on the insulation section hex. This insulation connection must not be disconnected.

Dk-Lok Tube Fittings

Nut DN

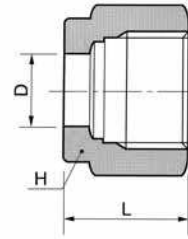

fractional

Part No.	Tube O.D.		Width across flat		L
	D		H		
	in	mm	in	mm	
DN-1	1/16	1.59	5/16	7.93	7.90
DN-2	1/8	3.17	7/16	11.11	11.93
DN-3	3/16	4.76	1/2	12.70	11.93
DN-4	1/4	6.35	9/16	14.28	12.70
DN-5	5/16	7.93	5/8	15.87	13.46
DN-6	3/8	9.52	11/16	17.46	14.22
DN-8	1/2	12.70	7/8	22.22	17.52
DN-10	5/8	15.87	1	25.40	17.52
DN-12	3/4	19.05	1-1/8	28.57	17.52
DN-14	7/8	22.22	1-1/4	31.75	17.52
DN-16	1	25.40	1-1/2	38.10	20.57
DN-20	1-1/4	31.75	1-7/8	47.63	31.75
DN-24	1-1/2	38.10	2-1/4	57.15	38.10
DN-32	2	50.80	3	76.20	52.32

metric

Part No.	Tube O.D.		Width across flat		L
	D		H		
DN - 2M	2		12		11.90
DN - 3M	3		12		11.90
DN - 4M	4		12		11.90
DN - 6M	6		14		12.70
DN - 8M	8		16		13.50
DN - 10M	10		19		15.10
DN - 12M	12		22		17.40
DN - 15M	15		25		17.40
DN - 16M	16		25		17.40
DN - 18M	18		30		17.40
DN - 20M	20		32		17.40
DN - 22M	22		32		17.40
DN - 25M	25		38		20.60
DN - 28M	28		46		30.60
DN - 32M	32		50		34.40
DN - 38M	38		60		40.60

Ferrule Set DFS



fractional

Part No.	Tube O.D.	
	in	mm
DFS-1	1/16	1.59
DFS-2	1/8	3.17
DFS-3	3/16	4.76
DFS-4	1/4	6.35
DFS-5	5/16	7.93
DFS-6	3/8	9.52
DFS-8	1/2	12.70
DFS-10	5/8	15.87
DFS-12	3/4	19.05
DFS-14	7/8	22.22
DFS-16	1	25.40
DFS-20	1-1/4	31.75
DFS-24	1-1/2	38.10
DFS-32	2	50.80

metric

Part No.	Tube O.D.
DFS-2M	2
DFS-3M	3
DFS-4M	4
DFS-6M	6
DFS-8M	8
DFS-10M	10
DFS-12M	12
DFS-14M	14
DFS-15M	15
DFS-16M	16
DFS-18M	18
DFS-20M	20
DFS-22M	22
DFS-25M	25
DFS-28M	28
DFS-30M	30
DFS-32M	32
DFS-38M	38

Nut-Ferrule Set DFSN



fractional

Part No.	Tube O.D.
DFSN-1	1/16
DFSN-2	1/8
DFSN-3	3/16
DFSN-4	1/4
DFSN-5	5/16
DFSN-6	3/8
DFSN-8	1/2
DFSN-10	5/8
DFSN-12	3/4
DFSN-14	7/8
DFSN-16	1
DFSN-20	1-1/4
DFSN-24	1-1/2
DFSN-32	2

metric

Part No.	Tube O.D.
DFSN-2M	2
DFSN-3M	3
DFSN-4M	4
DFSN-6M	6
DFSN-8M	8
DFSN-10M	10
DFSN-12M	12
DFSN-14M	14
DFSN-15M	15
DFSN-16M	16
DFSN-18M	18
DFSN-20M	20
DFSN-22M	22
DFSN-25M	25
DFSN-28M	28
DFSN-30M	30
DFSN-32M	32
DFSN-38M	38

Front Ferrule

DFF

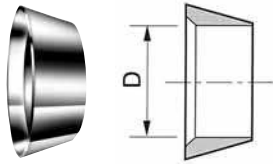

fractional

Part No.	Tube O.D. D	
	in	mm
DFF-1	1/16	1.59
DFF-2	1/8	3.17
DFF-3	3/16	4.76
DFF-4	1/4	6.35
DFF-5	5/16	7.93
DFF-6	3/8	9.52
DFF-8	1/2	12.70
DFF-10	5/8	15.87
DFF-12	3/4	19.05
DFF-14	7/8	22.22
DFF-16	1	25.40
DFF-20	1-1/4	31.75
DFF-24	1-1/2	38.10
DFF-32	2	50.80

metric

Part No.	Tube O.D. D
DFF-2M	2
DFF-3M	3
DFF-4M	4
DFF-6M	6
DFF-8M	8
DFF-10M	10
DFF-12M	12
DFF-15M	15
DFF-16M	16
DFF-18M	18
DFF-20M	20
DFF-22M	22
DFF-25M	25
DFF-28M	28
DFF-32M	32
DFF-38M	38

Back Ferrule

DFB

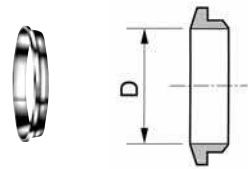

fractional

Part No.	Tube O.D. D	
	in	mm
DFB-1	1/16	1.59
DFB-2	1/8	3.17
DFB-3	3/16	4.76
DFB-4	1/4	6.35
DFB-5	5/16	7.93
DFB-6	3/8	9.52
DFB-8	1/2	12.70
DFB-10	5/8	15.87
DFB-12	3/4	19.05
DFB-14	7/8	22.22
DFB-16	1	25.40
DFB-20	1-1/4	31.75
DFB-24	1-1/2	38.10
DFB-32	2	50.80

metric

Part No.	Tube O.D. D
DFB-2M	2
DFB-3M	3
DFB-4M	4
DFB-6M	6
DFB-8M	8
DFB-10M	10
DFB-12M	12
DFB-15M	15
DFB-16M	16
DFB-18M	18
DFB-20M	20
DFB-22M	22
DFB-25M	25
DFB-28M	28
DFB-32M	32
DFB-38M	38

Preswaging Tool

DPS



Fractional Dk-Lok

Part No.	Tube O.D. (in.)
DPS-4-C	1/4
DPS-5-C	5/16
DPS-6-C	3/8
DPS-8-C	5/8
DPS-12-C	3/4

metric Dk-Lok

Part No.	Tube O.D. (mm)
DPS-3M-C	3
DPS-6M-C	6
DPS-8M-C	8
DPS-10M-C	10
DPS-12M-C	12
DPS-16M-C	16
DPS-18M-C	18
DPS-20M-C	20

Operation Instructions

Pre-swaging Tool (DPS)

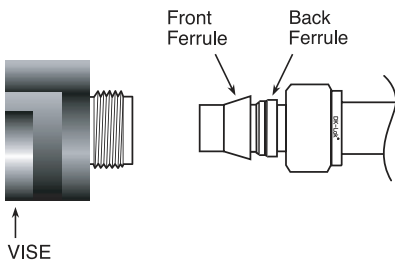

Operation on Pre-Swaging Tool

1. Clamp the DPS on the VISE steadily.
2. Install the Dk-Lok nut, ferrules onto the tubing.
3. Insert the loose ferrules and loose nut installed tubing end into the DPS until it is bottomed on the shoulder of the DPS.
4. Finger-tighten the nut.
5. Scribe the nut at the 6 o'clock position.
6. Wrench-tighten the nut 1 1/4 turns to the 9 o'clock position.
 - Tighten the nut 3/4 turn to the 3 o'clock position for 1/16, 1/8, and 3/16 in.; 2, 3, and 4 mm tube fittings.
7. Un-thread the nut.
8. Remove the tubing with pre-swaged ferrules from the DPS.
 - In case the tubing is difficult to remove from DPS, gently rock the tubing back and forth. Do not rotate the tubing.

Assembly on Fitting

1. Insert the ferrule pre-swaged tubing into the fitting body until the front ferrule seats.
2. Hand-tighten the nut.
3. Wrench-tighten the nut to the previously pulled-up position; at this point, a sharp rise in torque is felt.
4. Tighten slightly with a wrench.

Dk-Lok Tube Fittings

Gap Gauge DIG

This no-go gap gauge is useful tool to inspect the Dk-Lok initially pulled-up.

Operation Instructions

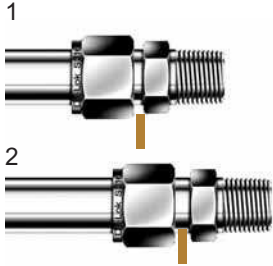

On initial assembly, apply Dk-Lok no-go gap inspection gauge to make sure that the make-up distance is sufficiently pulled-up.

Refer to Fig 1.

1. The gap gauge does not fit the gap between the nut and the body hex. This ensures that the fitting is sufficiently tightened on initial assembly.

Refer to Fig 2.

2. The gap gauge fits the gap between the nut and the body hex. The fitting requires an additional tightening.

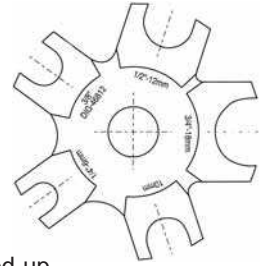

Part No.	Fitting Size	
	in.	mm
DIG-468	This gauge works on eight sizes	
	1/4, 3/8, 1/2, and 3/4.	6, 10, 12, and 18
DIG-5	5/16	-
DIG-12	3/4	-
DIG-16	1	25

Tube Depth Marking Tool DTM



Making on tubing prior to make-up with Dk-Lok. The making indicates that tubing is properly bottomed on fitting.

Fractional

Part No.	Tube O.D. (in.)
DTM-4-C	1/4
DTM-6-C	3/8
DTM-8-C	1/2
DTM-10-C	5/8
DTM-12-C	3/4
DTM-16-C	1

metric

Part No.	Tube O.D. (mm)
DTM-6M-C	6
DTM-8M-C	8
DTM-10M-C	10
DTM-12M-C	12
DTM-16M-C	16
DTM-25M-C	25

Pre-Swaging Units



Model:
Model No.:

Hydraulic Swaging Unit
DHS-2A



Electric Swaging Unit
DES-1A

Pre-swaging units for Dk-Lok ferrules onto tubing.

in.	1/2, 5/8, 3/4, 1, 1 1/4, 1 1/2, and 2.
mm	12, 14, 15, 16, 18, 20, 22, 25, 28, 30, 32, and 38.

Pre-swaging unit must be used to install 1 1/4, 1 1/2, and 2 in. and 28, 30, 32, and 38 mm fittings.

Contact Dk-Lok authorized distributor for operating manuals of DHA-2A and DES-1A.

Dk-Lok Tube Fittings

INSTALLATION INSTRUCTIONS

This instruction applies to Dk-Lok Tube Fittings as well as Dk-Lok Z series Tube Fittings.

Dk-Lok is supplied finger-tight and ready for immediate use. Therefore fitting disassembly is not necessary for installation.

Step 1.



Insert the tubing into the Dk-Lok tube fitting until the tubing end bottoms on the shoulder of the fitting body.

- Make sure the nut finger-tight.

Step 2.

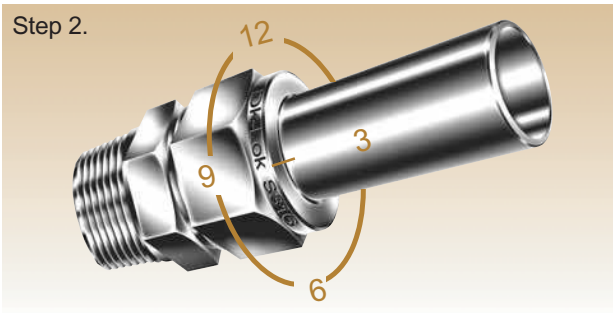

Scribe the nut at the 6 o'clock position and wrench-tighten the nut 1 1/4 turns to the 9 o'clock position, holding the body with a back up wrench.

- Tighten the nut 3/4 turn to the 3 o'clock position for 1/16, 1/8, and 3/16 in.; 2, 3, and 4mm tube fittings.

Dk-Lok Installation for High Pressure or High Safety Applications

1. Insert tubing on the Dk-Lok tube fitting until the tubing end bottoms on the shoulder of the fitting body.
2. Wrench-tighten the nut until the tubing does not rotate by hand or moves axially in the fitting.
3. Scribe the nut at 6 o'clock position.
4. Wrench-tighten the nut to the 9 o'clock position, holding the body with a back up wrench.
 - Only 3/4 turn to the 3 o'clock position is required for 1/16, 1/8, and 3/16 in.; 2, 3 and 4mm tube fittings.

Inspection of Gaugeable Dk-Lok fitting initially pulled-up

Dk-Lok tube fittings are gaugeable. This allows installer to inspect that the make-up distance is sufficiently pulled-up on initial assembly.

Refer to page on 77 for Gap Gauge Operation Instructions.

- Dk-Lok Gap Gauge is applicable to those Dk-Lok fittings made out of SS316, Carbon steel, Brass, and Exotic alloy materials.

Re-assembly Instructions

Dk-Lok can be used many times.

Prior to re-assembly, ensure the components are clean and free of defects.

1. Insert the ferrules swaged tubing into the body until the front ferrule seats firmly.
2. Hand-tighten the nut.
3. Wrench-tighten the nut to the previously pulled-up position; at this point, a sharp rise in torque is felt.
4. Tighten slightly with a wrench.

Tube handling during installation

1. Do not force the tubing into the fitting when it does not smoothly go in. It may be a deformed oval.
2. Use proper tube cutter and maintain a sharp cutting wheel on it.

Tube installation

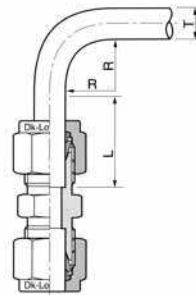

T : Tube O.D.

R : Radius

L : Straight tube length

In case tube bend is too close to a fitting, the bend section shall enter the fitting. This may not allow the tube to be bottomed in the fitting, resulting in leaks.

Keep the proper straight length of tube as shown in the tables.

- Do not bend a tube in the fitting. Use tube bender prior to installation onto fitting.

Fractional tube, in.	
T	L
1/16	1/2
1/8	23/32
3/16	3/4
1/4	13/16
5/16	7/8
3/8	15/16
1/2	1 3/16
5/8	1 1/4
3/4	1 1/4
7/8	1 5/16
1	1 1/2
1 1/4	2
1 1/2	2 13/32
2	3 1/4

Metric tube, mm	
T	L
3	19
6	21
8	23
10	25
12	31
14	32
15	32
16	32
18	32
20	34
22	34
25	40
28	46
30	50
32	54
38	63
50	80



Quality System Certifications

ISO 9001:2000	AP1149
ISO 14001:2004	HSBRSK
OHSMS 18001	HSBSK-S006
API	6D-0593
KEPIC	MN-227

Nuclear System and Product Certifications

ASME NPT	N-3186
ASME N	N-3185
ASME NB	N-3185

Directive 97/23/EC

TUV NORD	07-202-3537 WZ-0941/09
RWTUV	K1005/04

CNG/NGV

TUV SUD	07-000026-PA-GBM-00
---------	---------------------

Vacuum Test Certificate TA LUFT 2002

TUV Rheinland	973-10014584
---------------	--------------

CRN

ABSA	0A4788.2
ABSA	OC07988.2
ABSA	OC09275.2
ABSA	OC5191.2
ABSA	OC07988.2

GOST

GOST	POCC KR.MX05.B00226
GOST	POCC KR.MX05.B00227

Type Approval Certifications

ABS	BK720958-X
BV	14034/A1 BV
DNV	P-11926, P-12490
GL	47 924-03HH 47 925-03HH 40 504-01HH 40 505-01HH
KR	CWN80397-PE001
LR	01/10047 01/10048
NK	06FV101B

The information shown in this catalog are not for design purpose, but for reference only. The accuracy of information is not the liability of our company.

Safe Component Selection

The Selection of component for any applications or system design must be considered to ensure safe performance. Component function, material compatibility, component ratings, proper installation, operation and maintenance remain the sole responsibility of the system designer and the user. DK Tech accepts no liability for any improper selection, installation, operation or maintenance.



Dk Tech Corporation

Head Quarters and Factory
826, Naesam-Ri, JuChon-Myeon, Kimhae-city, South Korea 621-841
Phone : 82) 55-338-0114
Fax : 82) 55-338-6743 / 6744 / 6745 / 6746