

O'Brien offers two windows for the 500 and 700 series enclosures. Solid neoprene gasket maintains IP65 rating.

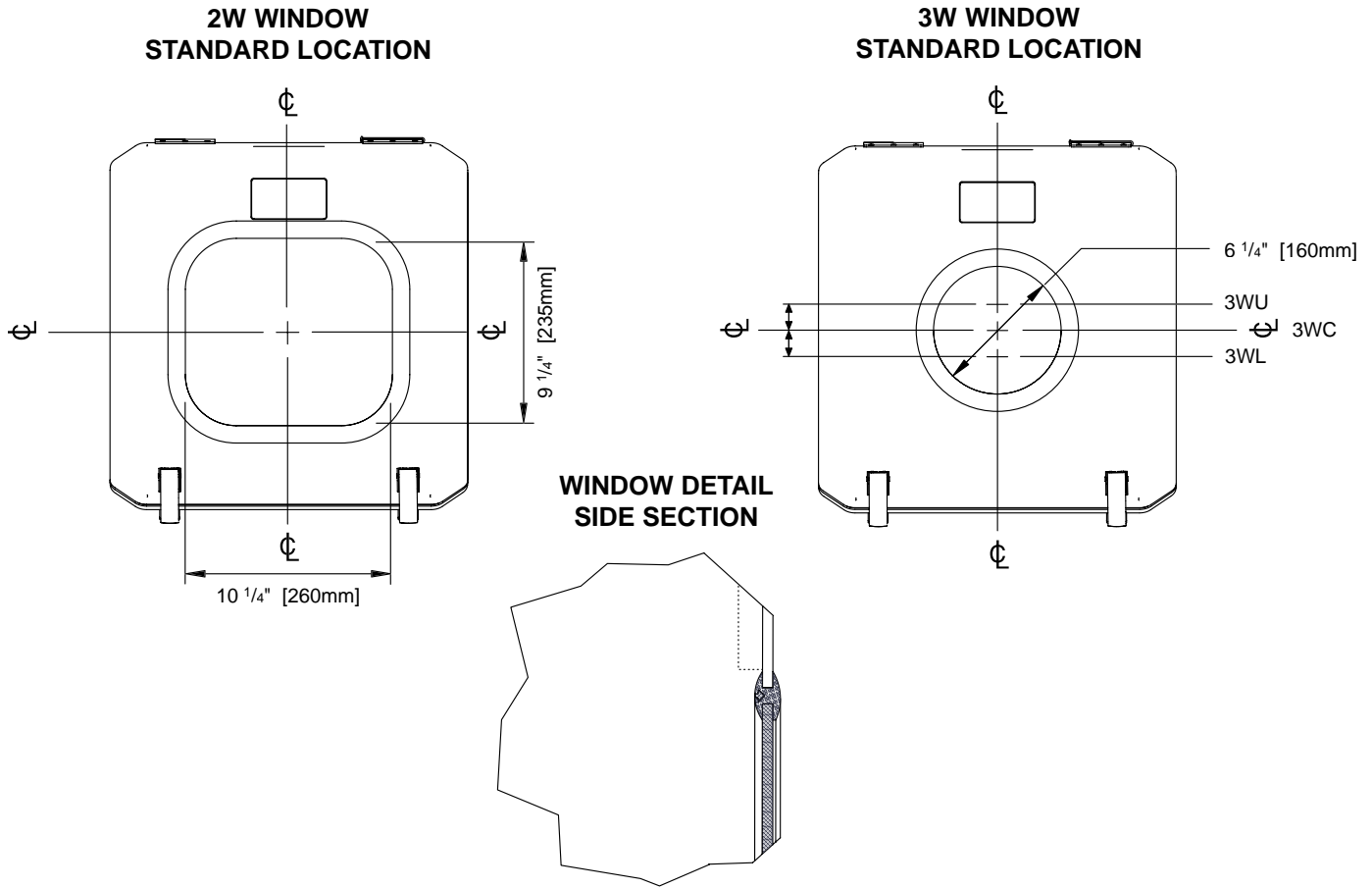

Specifications (2W)

Material

Window: Tempered Glass
Gasket: Neoprene

Size

250mm W x 280mm H

Viewable Area

230mm W x 260mm H

Standard Location

Front center

Weight

0.9 Kg (2 Lb)

Specifications (3W)

Material

Window: Tempered Glass
Gasket: Neoprene

Size

180mm diameter

Viewable Area

150mm diameter

Standard Locations

3WC: front center

3WU: +35mm vertically from front center

3WL: -35mm vertically from front center

Weight

0.5 Kg (1.1 Lb)

Specifications subject to change without notice.

Worldwide Offices:

USA: 1900 Crystal Industrial Court • St. Louis, Missouri 63114 • Ph: 314/236-2020 • Fax: 314/236-2080

BELGIUM: Mallekotstraat 65 • B 2500 Lier, Belgium • Ph (+32) 3 491 9875 • Fax (+32) 3 491 9876

CANADA: Suite 400 • 609 14th Street NW • Calgary, AB T2N 2A1 • Ph 403/730-7277 • Fax 403/730-7279

obcorp@obcorp.com • www.obcorp.com