

COMPONENTI PER L'AUTOMAZIONE PNEUMATICA
COMPONENTS FOR PNEUMATIC AUTOMATION



MANUALE / HANDBOOK

**REGOLATORI DI PRESSIONE
PROPORZIONALI con CANopen**

**ELECTRONIC PROPORTIONAL
REGULATORS with CANopen**





FEATURES

Pneumatic	Fluid	Air filtered at 5 micron and dehumidified			
	Minimum inlet pressure	Desired outlet pressure + 1 bar			
	Maximum inlet pressure	10 bar			
	Outlet pressure	Order code	0009	0005	0001
		Pressure value	0 ÷ 9 bar	0 ÷ 5 bar	0 ÷ 1 bar
	Nominal flowrate from 1 to 2 (6 bar Δp 1 bar)	Size 0	Size 1	Size 3	
		7 NI /min	1.100 NI /min	4.000 NI/min	
	Discharge flowrate (at 6 bar with 1 bar overpressure)	7 NI /min	1.300 NI /min	4.500 NI/min	
	Air consumption	< 1 NI/min	< 1 NI/min	< 1 NI/min	
	Supply connection	M5	G 1/4"	G 1/2"	
Outlet connection	M5	G 1/4"	G 1/2"		
Exhaust connection	$\varnothing 1,8$	G 1/8"	G 3/8"		
Maximum fitting tightening torque	3 Nm	15 Nm	15 Nm		
Electric	Supply voltage	24V DC \pm 10% (stabilised with ripple <1%)			
	Standby current consumption	55 mA			
	Current consumption with solenoid valves on	145 mA			
	Connector	D-sub 15 poles			
Functional	Linearity	< \pm 0,3 % F.S.			
	Hysteresis	< 0,3 % F.S.			
	Repeatability	< \pm 0,3 % F.S.			
	Sensitivity	< \pm 0,3 % F.S.			
	Assembly position	Indifferent			
	Protection grade	IP65 (with casing fitted)			
Ambient temperature	$-5^{\circ} \div 50^{\circ}\text{C} / 23^{\circ} \div 122^{\circ}\text{F}$				
Constructional	Body	Anodised aluminium			
	Shutters	Brass with vulcanised NBR			
	Diaphragm	Cloth-covered rubber			
	Seals	NBR			
	Cover for electrical part	Technopolymer			
	Springs	AISI 302			
	Weight	Size 0	Size 1	Size 3	
168 gr.		360 gr	850 gr		



FEATURES

Installation/Operation

PNEUMATIC CONNECTION

The compressed air is connected by means of M5 threaded holes (for size 0 regulator), G1/4" threaded holes (for size 1 regulators) and G1/2" threaded holes (for size 3 regulators) in the body.



Before making the connections, eliminate any impurities in the connecting pipes to prevent chippings or dust entering the unit. Do not supply the unit with more than 10 bar pressure and make sure that the compressed air is dried (excessive condensate could cause the appliance to malfunction) and filtered at 5 micron. The supply pressure to the regulator must always be at least 1 bar greater than the desired outlet pressure.

If a silencer is applied to the Exhaust port the unit's response time may change; periodically check that the silencer is not blocked and replace it if necessary.

ELECTRICAL CONNECTION

For the electrical connection a SUB-D 15-pole female connector is used (to be ordered separately). Wire in accordance with the wiring diagram shown below.



Warning: INCORRECT CONNECTIONS MAY DAMAGE THE DEVICE

NOTES ON OPERATION

If the electric supply is interrupted, the outlet pressure is maintained at the set value. However, maintaining the exact value cannot be ensured as it is impossible to operate the solenoid valves. In order to discharge the circuit downstream, zero the reference, make sure that the display shows a pressure value equal to zero and then disconnect the electric power supply. A version of the device is available that exhausts the downstream circuit when the power supply is removed. (Option "A" at the end of the ordering code).



If the compressed-air supply is suspended and the electric power supply is maintained a whirring will be heard that is due to the solenoid valves; an operating parameter can be activated (P18) that triggers the regulator protection whenever the requested pressure is not reached within 4 seconds of the reference signal being sent. In this case the system will intervene to interrupt the control of the solenoid valves. Every twenty seconds, the unit will start the reset procedure until standard operating conditions have been restored.

TOP VIEW
OF THE REGULATOR
CONNECTOR

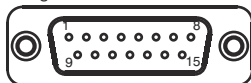
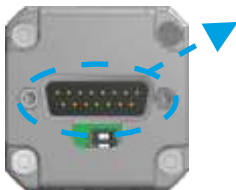

CONNECTOR PIN:

- 1 = CAN_SHLD
- 2 = CAN_V+
- 3 = CAN_GND
- 4 = CAN_H
- 5 = CAN_L
- 6 =
- 7 =
- 8 =
- 9 = SUPPLY (24 VDC)
- 10 = CAN_SHLD
- 11 = CAN_V+
- 12 = CAN_GND
- 13 = CAN_H
- 14 = CAN_L
- 15 = GND

FEATURES

Display features

The proportional regulator has a 3 1/2 digit display and a three-pushbutton touchpad by means of which information on regulator status can be displayed and the functional and operating parameters can be set.



Using the display in “standard” mode

When the regulator is switched on, the display shows the outlet pressure value detected by the internal transducer. This value can be displayed in 3 different measuring units (Bar - PSI - MPa) that can be selected by the user.

If the right-hand key (\blacktriangle) is pressed during normal operation of the regulator, the desired pressure value appears. This value is expressed in the unit of measurement that has been set by the user. As the pressure regulator has 2 different modes for managing the reference signal, if during normal operation the left-hand key (\blacktriangleleft) is kept pressed the display will show a letter and a number alternately. The letter indicates the reference source that the regulator is using whilst the number indicates the reference value

Display letter	Meaning	Value
	CANopen	Bar (es 1.22)
	Keyboard	Bar (es 1.22)

Setting desired pressure value from display

If the regulator is configured to use the keyboard of the display as the reference source, press the central key (**SET**) for 2 seconds to set the desired pressure directly. In particular, the display shows the currently set pressure value, with the last digit on the right flashing (modifiable digit).

Press the right-hand key (\blacktriangle) to increase the value of the flashing digit and press the left-hand key (\blacktriangleleft) to move to the following digit. Repeat the operation for all the characters (the selected character will be recognisable by the flashing). Once the desired value has been set, press key (**SET**) to save it permanently to the memory.

If the entered value is acceptable (it belongs to the preset use range and is not in conflict with the value of other parameters), the display confirms that the value has been entered by flashing twice (it switches off and lights up again twice to indicate the set value). The value is saved into P0 parameter.

If the entered value is not acceptable (outside limits set by manufacturer or in conflict with other parameters) the display shows an error signal.

If the entered value is less than the lower limit the message **ELo** appears and the device proposes the minimum permitted value. If the entered value is greater than the upper limit the message **EHi** appears and the device proposes the maximum permitted value.



FEATURES

Using the display in “modify parameters” mode

To enter “**modify parameters**” mode, press the left-hand (◀) and right-hand (▶) keys simultaneously for 2 seconds.

If the password is not enabled, the user accesses the main configuration menu. If the password is enabled the message **PSv** appears on the display followed by the request to enter the value of the password:



To enter the value of the password, proceed in this manner: press the right-hand key (▶) to increase the value of the flashing digit and then press the left-hand key (◀) to move to the next digit. Repeat the operation for all the characters (the selected character flashes).

N.B.: the fourth character can have only the values 0 and 1. 0 is displayed when the point at the bottom on the left is switched on:



Once the desired value has been set, press the key (**SET**). If this is correct, you will enter the main configuration menu directly. If the password has not been entered correctly the message **EEE** will appear on the display and it will not be possible to access the main configuration menu. The device will thus return to “standard” mode.

Defining parameters

The proportional regulator can be fully customised to meet the needs of the end user. In particular, the device associates with its operating configuration variable details that can be accessed directly via the display or **CANopen** protocol. These are from now on defined as **PARAMETERS**.

By varying the parameters it is possible to intervene on the following regulator features:

Insensitivity

Unit of measurement of the pressure displayed on the display

Choosing the reference source

Activating the protection for the solenoid valves

Enabling password and corresponding value

Speed of convergence on the desired pressure.

In addition to these parameters, there are also three parameters related to **CANopen** communication:

Speed

Address

Thresholds for indication of desired pressure reaching

Main configuration menu

Once the user has entered the main configuration menu (with the previously described procedure), the display is as follows:



A identifies the address selection mode.

By pressing the key (**SET**) it is possible to set the address.

The display shows the current value and enables it to be modified with the same procedure as for entering the password.

Once the address is set, press the key (**SET**) to return to the main configuration menu.

By pressing the right-hand key (**▲**) the display is as follows:



S identifies the speed selection mode.

By pressing the key (**SET**) it is possible to set the speed.

The display shows the current value and enables it to be modified with the same procedure as for entering the password.

Once the address is set, press the key (**SET**) to return to the main configuration menu.

By pressing the right-hand key (**▲**) the display is as follows:



P identifies the parameter selection mode.

By pressing the key (**SET**) it is possible to set all the parameters.

The parameter selection mode doesn't allow to return to main configuration menu.

If the key (**SET**) has not been pressed,

by pressing the right-hand key (**▲**) the display is as follows:



Once all the values have been modified, in order to enable all the modified values to be saved and to return to the standard operating mode, press the right-hand (**▲**) and left-hand (**◀**) keys simultaneously for about two seconds.

The regulator confirms the change of operating mode by showing this symbol on the display for about half a second.





Modifying parameters

Once the user has entered the parameters configuration menu (with the previously described procedure), the display is as follows: 

P identifies the parameter selection mode whilst the number displayed on the right indicates the parameter number.

Press the right-hand key (**▲**) to change the parameter number from (P0) to (P22). Each time the key is pressed the number increases; if the key is kept pressed the parameter number increases automatically. Once you have identified the parameter that you wish to display or modify, press the key (**SET**) to access it. After the key (**SET**) has been pressed the display shows the current value of the selected parameter and enables it to be modified. Depending on the type of parameter, 1 or more characters may be displayed. The procedure for modifying the values is the same as for entering the password: it is possible to modify just one character at a time (the flashing character) by pressing the right-hand key (**▲**). On the other hand, if the left-hand key (**◀**) is pressed, the active character is changed (for those parameters that have more than one character). Once the value to be assigned to the parameter has been set, press the key (**SET**) to confirm the selection made.

If the entered value is acceptable (it belongs to the preset use range and is not in conflict with the value of other parameters) the display confirms that the value has been entered by flashing twice (it switches off and switches on again twice to indicate the set value). A parameter that has been modified in this way is said to have been CONFIRMED.

When flashing stops the regulator returns to the parameter selection (it again displays the message "P X", X being the last parameter to have been modified). If the entered value is not acceptable (outside the limits set by the manufacturer or in conflict with other parameters) the display shows an error message. If the entered value is less than the lower limit the message **ELO** appears and the device proposes the minimum permitted value. If the entered value is greater than the upper limit the message **EHI** appears and the device proposes the maximum permitted value.

N.B.: the proposed values are not automatically confirmed. To confirm, press the key (**SET**).



By proceeding in this way (parameter selection, subsequent modification and confirmation) it is possible to modify the value of all the parameters. Once all the values have been modified, in order to enable all the modified values to be saved and to return to the standard operating mode, press the right-hand (**▲**) and left-hand (**◀**) keys simultaneously for about two seconds.

The regulator confirms the change of operating mode by showing this symbol on the display for about half a second. 

Warning

-  Whilst the regulator is in "modify parameters" mode (main, address, speed and parameters configuration menu)
 - **CAN**open communication is disabled.
 - outlet pressure is not adjusted, so it cannot be guaranteed that desired pressure corresponds to the outlet pressure.



-  Press the two keys (**◀**) (**▲**) to leave "modify parameters" mode: all the CONFIRMED parameters are saved to the permanent memory and are thus maintained even after switch-off.
-  In order to leave "modify parameters" mode without saving any modified parameter (not even confirmed parameters) wait for two minutes to elapse without pressing any key. Alternatively, switch off the regulator and switch it on again.
-  If the regulator is switched off whilst it is in "modify parameters" mode no modified parameter is saved to the permanent memory even if it has already been confirmed.



List of parameters

CANopen ADDRESS

Defines the node address for the CANopen communication.

Default value	Unit of measurement	Range
1	/	From 1 to 128

CANopen COMMUNICATION SPEED

Defines the node speed for the CANopen communication.

Default value	Unit of measurement	Range
7	/	From 0 to 7

Value	Meaning
0	10 Kbit/sec
1	20 Kbit/sec
2	50 Kbit/sec
3	125 Kbit/sec
4	250 Kbit/sec
5	500 Kbit/sec
6	800 Kbit/sec
7	1000Kbit/sec

PARAMETER 0 Desired pressure from keyboard

Defines the desired regulator outlet pressure value

Default value	Unit of measurement	Range
0	Bar	From minimum pressure (P3) to maximum pressure (P4)



Warning: This parameter becomes active only if the parameter P10 is set at 1. Minimum pressure (P3) and maximum pressure (P4) are the operating range. If these values are subsequently modified and the desired pressure value is outside this new range, the device will set the desired pressure (P0) **automatically** at the nearest permitted value

PARAMETER 1 Insensitivity

Defines the minimum deviation between desired pressure and outlet pressure beyond which the regulator intervenes.

Default value	Unit of measurement	Range
0.03	Bar	From 0.02 to 0.20 with parameter 22 at 0 - 1 - 2 From 0.01 to 0.20 with Parameter 22 at 3 - 4

If the difference between outlet pressure and desired pressure exceeds or falls below the P1 parameter value the regulator intervenes to increase or decrease the outlet pressure until the set value is reached



Warning: the smaller the set insensitivity value, the smaller the tolerated deviation will be. In this way, the regulator intervenes much more frequently to control the solenoid valves, generating small variations in outlet pressure.

**PARAMETER 2 Display unit of measurement**

Defines the unit of measurement that will be used on the display to show outlet pressure and desired pressure during operation in "standard" mode.

Default value	Unit of measurement	Range
0	/	From 0 to 2

Value	Meaning	Displayed value
0	Bar	0.00
1	PSI	000
2	MPa	00.0



Warning: All the other parameters linked to pressure (P0, P1, P3, P4, P8, P9), are measured in bar.

PARAMETER 3 Minimum pressure

Defines the (minimum) outlet pressure value corresponding to the minimum value of the reference signal. The range varies according to the model of transducer used.

Minimum pressure must be at least 0.1 bar less than maximum pressure

Product code	Value default	Unit of measurement	Range
17#E2N.S.C.0009.#	0.00	Bar	From 0.00 to 8.90
17#E2N.S.C.0005.#	0.00	Bar	From 0.00 to 4.90
17#E2N.S.C.0001.#	0.00	Bar	0.90

PARAMETER 4 Maximum pressure

Defines the (maximum) outlet pressure value corresponding to the maximum value of the reference signal. The default value and the range vary according to the model of transducer used. Maximum pressure must be at least 0.1 bar greater than minimum pressure

Product code	Value default	Unit of measurement	Range
17#E2N.S.C.0009.#	9.00	Bar	From 0.10 to 9.00
17#E2N.S.C.0005.#	5.00	Bar	From 0.10 to 5.00
17#E2N.S.C.0001.#	1.00	Bar	From 0.10 a 1.00

PARAMETER 8 Lower threshold for indication of desired pressure reaching

The **CANopen** object 0x6041 (Device status word) provides an indication that the outlet pressure corresponds to the desired pressure. In particular its "RT" bit is activated when outlet pressure falls within a range defined by a lower threshold and an upper threshold, both of which can be modified by the user.

The "RT" bit is active if the outlet pressure is greater than the desired pressure less the lower threshold and is lower than the desired pressure plus the upper threshold.

Example: desired pressure: 3 bar, lower threshold: 0.5 bar, upper threshold: 0.8 bar

The "RT" bit is active if the outlet pressure is between 2.5 bar (3 - 0.5) and 3.8 bar (3 + 0.8).

Default value	Unit of measurement	Range
0.50	Bar	From 0.10 to 1.00

PARAMETER 9 Upper threshold for indication of desired pressure reaching

See description of parameter P8.

Default value	Unit of measurement	Range
0.50	Bar	From 0.10 to 1.00

**PARAMETER 10** **Reference source**

Defines the reference source that the regulator has to use to set outlet pressure.

Default value	Unit of measurement	Range
0	/	From 0 to 1

Value	Meaning
0	CANopen
1	Keyboard

- 0 The regulator sets outlet pressure using the command coming from the **CANopen** port.
 1 The regulator sets outlet pressure directly from the keyboard. The parameter **P0** is used to set pressure.

PARAMETER 18 **Protection mode**

If during operation in "standard" mode the desired pressure cannot be reached (for example, there is no compressed-air supply or it is insufficient) or the discharge conduit is blocked or closed, the regulator continues to work on the solenoid valves to try to reach the desired pressure. This parameter allows the automatic switch-off of the control solenoid valves for up to 20 seconds to be enabled.

This function is used to safeguard the solenoid valves over time.

The protection is triggered if the desired pressure is not reached and the outlet pressure does not undergo significant variations within a 4-seconds control of the solenoid valves.

A significant variation is defined as a variation that is greater than the defined insensitivity value, parameter **P1**. After the 4 seconds have elapsed in which the regulator attempts to reach the desired pressure, the protection is triggered. This protection switches off the solenoid valves for a maximum of 20 seconds.

If the 20 seconds have elapsed or if during the 20 seconds during which the solenoid valves are switched off the required pressure (reference) varies or the outlet pressure varies the regulator will again start to control the solenoid valves for another 4 seconds, trying to reach the desired pressure.

If this does not occur, the protection is reactivated.

From this point on 4 seconds of controlling the solenoid valves and 20 seconds of switch-off alternate cyclically. When the protection is activated, the message **P18** appears on the display alternating with the messages **EHi** or **ELo** indicating that the regulator is not reaching the desired pressure due to filling (**ELo** lack of air) or pressure discharge difficulties (**EHi** discharge conduit blocked).

Default value	Unit of measurement	Range
0	/	From 0 to 1

Value	Meaning
0	Deactivated
1	Activated



PARAMETER 19 Enabling password request

Set this parameter at 1 to enable the password request: this will be requested whenever an attempt is made to access to the main configuration menu.

Default value	Unit of measurement	Range
0	/	From 0 to 1

Value	Meaning
0	Password deactivated
1	Password activated

By setting this parameter to 1 the protective password will be switched on, the password will be requested every time that the user will try to access the main configuration menu.



Attention: before enabling the password verify and , if necessary, modify parameter P20

PARAMETER 20 Password value

This parameter is the password. If the password request (parameter P19) is enabled, this value must be entered whenever an attempt is made to access to the main configuration menu.

N.B.: the fourth character can have only the values 0 and 1.

0 is displayed when the point at the bottom on the left is switched on:

Default value	Unit of measurement	Range
000	/	From 000 to 1999

PARAMETER 21 Default value

Restores all user configuration parameters to default values.

In order to activate the command that restores parameters to values set by manufacturer, enter the value "333" on the display and confirm the entry.



Warning: all changes made previously will be lost (except for parameters P19 and P20)

PARAMETER 22 Intervention mode

Defines the mode for converging on the desired pressure that the regulator should use

Default value	Unit of measurement	Range
0	/	From 0 to 4

Value	Meaning
0	Standard mode
1	Efficient mode
2	Accurate mode
3	Sensitive mode
4	Fast mode*

*Fast mode was specifically designed for size 0 regulators, in order to have the maximum speed in filling the circuit.

We suggest to use this mode only with size 0 regulators.

Every intervention mode characterises in a particular way the proportional regulator behaviour.

In particular:

- Standard mode is a trade-off between speed and accuracy.
- Efficient mode controls solenoid valves to allow a bigger change of outlet pressure. This grants a lower time to fill / empty a volume. It is specially suitable if there is a big volume to manage or if the inlet airflow is low. As a result of the high fill/empty speed the desired pressure can occasionally be exceeded for a short time.
- Accurate mode controls solenoid valves to manage outlet pressure more softly. It is particularly suitable if there is a little volume to manage or if the inlet airflow is high. This mode is slower than others.



- Sensitive mode follows with higher speed changes of desired pressure. It is particularly suitable if it is needed to keep constant outlet pressure even if it is changed by the particular application (e.g. Working with inconstant outline).

N.B.: Every mode suits better some particular applications than others.

 The parameters to be considered are inlet airflow, volume to manage, speed and accuracy.

It is suggested to make a test with each mode to verify on working condition which is the most suitable.

AUTOMATIC RESOLUTION OF POSSIBLE CONFLICTS BETWEEN SET PARAMETERS

The regulator does not permit desired pressures - parameter P0 and the desired **CAN** open pressure - to be set outside the operating range (pressure range) defined by the parameters P3 and P4.



Warning: make sure that the parameters P3 and P4 have been entered correctly as the regulator will **automatically** modify any desired pressure that is outside the operating range.

The value assigned will correspond to the nearest permitted value

MODEL WITH EXTERNAL FEEDBACK

If you order the version with the external feedback there is a M5 threaded connection to which connect the feedback pressure (to the pressure transducer). This connection is placed on the outlet connection side. This option allows to take the signal from a remote point instead of directly from the outlet connection; this function is typically used when the regulated pressure is used far away to the regulator.



Warning: if you order a device with the external feedback option (option «E» at the end of the ordering code) you cannot use this model as the standard (you should always take the pneumatic signal to the M5 connection).



CANopen communication

This model of the proportional regulator features the **CANopen** port that enables a direct connection between the regulator itself and a computer or a PLC (provided with a **CANopen** port) to be established. The regulator has a set of commands that enable all the previously described parameters to be read and modified (except for parameters P0, P19, P20 and P21). In addition to this, **CANopen** protocol can be used to read and set the desired pressure and to read the outlet pressure.



Attention: When **CANopen** protocol is used the unit of measurement of parameters P1, P3, P4, P8, P9, desired pressure and outlet pressure is millibar.

Terminating resistor

CANopen protocol requires that the first and the last node of the network have included the terminating resistor.

On the proportional regulator there are two switches near the power supply connector.

Terminating resistor is managed by the switch that is nearer to the connector (see picture)

The other switch is not connected.



LED indications

The proportional regulator with **CANopen** is fitted with 2 LED (1 red and 1 green), which indicate the device working state as follows:

RED LED (ERR)	GREEN LED (BUS)	DESCRIPTION
OFF	OFF	TURNED OFF or INIT status
OFF	BLINKING	PREOPERATIONAL status
OFF	SINGLE FLASH	STOPPED status
OFF	ON	OPERATIONAL status
FLICKERING	OFF	Node address = 0
SINGLE FLASH	ON/BLINKING	CAN communication error
DOUBLE FLASH	ON	GUARD TIME error



The **.eds** file for node configuration is downloadable from www.pneumaspa.com

Principio di funzionamento / Working principle:

Questo modello di regolatore proporzionale è aderente alle specifiche C.i.A. Draft Standard 408
Il funzionamento del regolatore proporzionale può essere riassunto con due macchine a stati:

- la macchina a stati del dispositivo ("Device State Machine")
- la macchina a stati della comunicazione ("Communication State Machine")

La due macchine a stati sono qui di seguito schematizzate:

*This proportional regulator model conforms to C.i.A. Draft Standard 408 specifications.
The proportional regulator working can be summarized with two state machines:*

- The "Device State Machine"
- The "Communication State Machine"

These two state machines are described as follows:

Communication state machine

Power on

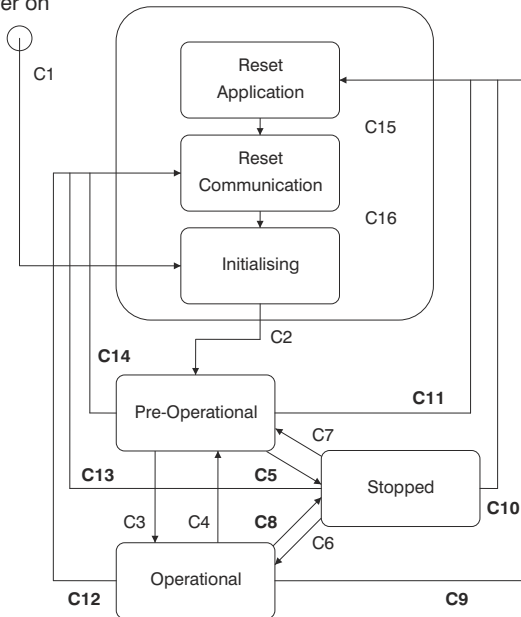



Device state machine

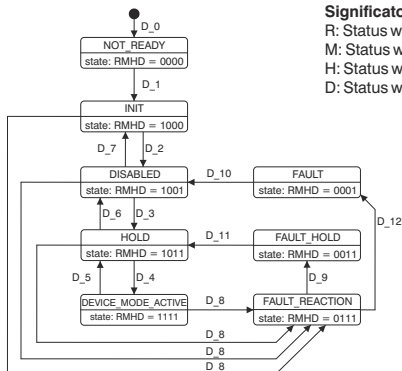

Significato di RMHD / Meaning of RMHD:

- R: Status word Ready (Bit 3)
- M: Status word Device Mode Active Enable (Bit 2)
- H: Status word Hold activated (Bit 1)
- D: Status word Disabled (Bit 0)

Transizioni di stato dipendenti dalla control word

I comandi di tipo "device control", che causano una transizione di stato, sono composti dai quattro bit meno significativi della control word (oggetto 0x6040)

La tabella seguente riporta solo le transizioni che dipendono dalla control word. La tabella mostra le condizioni che la control word deve soddisfare. Devono essere verificati solo i campi contenenti i numeri.

Le transizioni 10 e 11 sono eseguite solo se il bit di reset cambia da 0 a 1. Le transizioni 10 e 11 si attivano sul fronte di salita.

I bit contrassegnati con una "x" sono irrilevanti per la corrispondente transizione di stato.

State transitions depending on the control word

The device control commands, which cause a state transition, are formed by the four low-order bits of the control word (Object 0x6040)

The following table lists only the transitions depending on the control word. It shows the conditions which the control word needs to fulfill. Only the fields holding numbers are being verified.

The transitions 10 and 11 are only executed if the reset bit changes from 0 to 1. Transitions 10 and 11 are triggered on the rising edge.

The bits designated with an "x" are irrelevant for the corresponding state transition.

State transition	Device control command	Control word bit			
		3	2	1	0
		R	M	H	D
D_2	Activate "DISABLED"	x	x	x	1
D_3	Activate "HOLD"	x	x	1	1
D_4	Activate "DEVICE_MODE"	x	1	1	1
D_5	Deactivate "DEVICE_MODE"	x	0	x	x
D_6	Deactivate "HOLD"	x	0	0	x
D_7	Deactivated "DISABLED"	x	0	0	0
D_9	Activate "FAULT_HOLD"	0	x	1	x
D_10	Reset "FAULT" (disabled)	1	x	0	x
D_11	Reset "FAULT_HOLD"	1	x	1	x
D_12	Activate "FAULT"	0	x	0	x

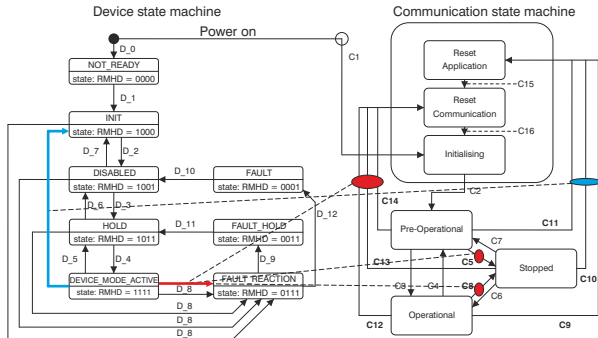

Se la Device State Machine è nello stato `DEVICE_MODE_ACTIVE`, le transizioni nella Communication State Machine forzano le seguenti transizioni:

- Le transizioni C5 e C8 nella Communication State Machine (Pre-operational -> Stopped, Operational -> Stopped) forzano la transizione D8 nella Device State Machine (`DEVICE_MODE_ACTIVE` -> `FAULT_REACTION`).
- Le transizioni C12, C13 and C14 nella Communication State Machine (Operational -> Reset Communication, Stopped -> Reset Communication and Pre-operational -> Reset Communication) forzano la transizione D8 nella device state machine (`DEVICE_MODE_ACTIVE` -> `FAULT_REACTION`).
- Le transizioni C9, C10 and C11 nella Communication State Machine (Operational -> Reset Application, Stopped -> Reset Application and Pre-operational -> Reset Application) forzano la transizione nella Device State Machine da `DEVICE_MODE_ACTIVE` a `INIT`.

If the device state machine is in mode `DEVICE_MODE_ACTIVE`, transitions in the communication state machine force the following reactions:

- *The transitions C5 and C8 in the communication state machine (Pre-operational -> Stopped, Operational -> Stopped) force the transition D8 in the device state machine (`DEVICE_MODE_ACTIVE` -> `FAULT_REACTION`).*
- *The transitions C12, C13 and C14 in the communication state machine (Operational -> Reset Communication, Stopped -> Reset Communication and Pre-operational -> Reset Communication) force the transition D8 in the device state machine (`DEVICE_MODE_ACTIVE` -> `FAULT_REACTION`).*
- *The transitions C9, C10 and C11 in the communication state machine (Operational -> Reset Application, Stopped -> Reset Application and Pre-operational -> Reset Application) force a transition in the device state machine from `DEVICE_MODE_ACTIVE` to `INIT`.*

Note / Note:

Per poter erogare la pressione, è necessario che il proporzionale sia contemporaneamente nello stato "Operational" della Communication State Machine e "Device Mode Active" della Device State Machine. Per passare nello stato di "Operational" occorre:

- Mandare un comando NMT per mettere il dispositivo nello stato di "Operational"
- Per passare nello stato di "Device Mode Active" occorre:
- Scrivere "1" nella control word (oggetto 0x6040) per andare nello stato di "Disabled"
- Scrivere "3" nella control word (oggetto 0x6040) per andare nello stato di "Hold"
- Scrivere "7" nella control word (oggetto 0x6040) per andare nello stato di "Device mode Active"

In order to provide an output pressure, the proportional regulator must be at the same time in the "Operational" status of the Communication State Machine and in the "Device Mode Active" status of the Device State Machine.

- To go into the "Operational" status it's needed:*
- To send an NMT command to put the regulator into the "Operational" status.*
- To go into the "Device Mode Active" status it's needed:*
- To write "1" into the control word (object 0x6040) to go into the "Disabled" status.*
- To write "3" into the control word (object 0x6040) to go into the "Hold" status.*
- To write "7" into the control word (object 0x6040) to go into the "Device mode Active" status.*



Elenco oggetti gestiti / Managed objects list

INDEX	SUB	ACCESS	TYPE	DESCRIPTION
0x1000	0x00	ro	Unsigned32	Device type
0x1101	0x00	ro	Unsigned8	Error Register
0x1003	0x00	rw	Unsigned8	Pre-defined Error Field
	0x01	ro	Unsigned32	Standard error field
	0x02	ro	Unsigned32	Standard error field
	0x03	ro	Unsigned32	Standard error field
	0x04	ro	Unsigned32	Standard error field
	0x05	ro	Unsigned32	Standard error field
	0x06	ro	Unsigned32	Standard error field
	0x07	ro	Unsigned32	Standard error field
	0x08	ro	Unsigned32	Standard error field
	0x09	ro	Unsigned32	Standard error field
	0x0A	ro	Unsigned32	Standard error field
0x1005	0x00	ro	Unsigned32	COB-ID SYNC
0x1008	0x00	ro	Visible String	Manufacturer device name
0x1009	0x00	ro	Visible String	Manufacturer hardware version
0x100A	0x00	ro	Visible String	Manufacturer software version
0x100C	0x00	rw	Unsigned16	Guard time
0x100D	0x00	rw	Unsigned8	Life time factor
0x1014	0x00	ro	Unsigned32	COB-ID EMCY
0x1017	0x00	rw	Unsigned16	Producer heartbeat time
0x1018	0x00	ro	Unsigned8	Identity object
	0x01	ro	Unsigned32	Vendor-ID
0x1200	0x00	ro	Unsigned8	SDO server parameter
	0x01	ro	Unsigned32	COB-ID client - > server
	0x02	ro	Unsigned32	COB-ID server - > client
0x1400	0x00	rw	Unsigned8	RPDO communication parameter
	0x01	rw	Unsigned32	COB-ID used by RPDO
	0x02	rw	Unsigned8	transmission type
0x1600	0x00	rw	Unsigned8	RPDO mapping parameter
	0x01	rw	Unsigned32	1 st application object
	0x02	rw	Unsigned32	2 nd application object
0x1800	0x00	rw	Unsigned8	TPDO communication parameter
	0x01	rw	Unsigned32	COB-ID used by RPDO
	0x02	rw	Unsigned8	transmission type
0x1A00	0x00	rw	Unsigned8	TPDO mapping parameter
	0x01	rw	Unsigned32	1 st application object
	0x02	rw	Unsigned32	2 nd application object
0x2001	0x00	rw	Unsigned8	Insensitivity
0x2002	0x00	rw	Unsigned8	Display unit
0x2003	0x00	rw	Unsigned16	Minimum pressure
0x2004	0x00	rw	Unsigned16	Maximum pressure
0x2008	0x00	rw	Unsigned16	Lower threshold
0x2009	0x00	rw	Unsigned16	Upper threshold
0x2018	0x00	rw	Unsigned8	Valve protection
0x2022	0x00	rw	Unsigned8	Intervention mode
0x3000	0x00	rw	Unsigned8	Enabling Set
0x6040	0x00	rw	Unsigned16	Device control word
0x6041	0x00	ro	Unsigned16	Device status word
0x6043	0x00	ro	Integer8	Device control mode
0x604F	0x00	rw	Integer8	Device local
0x605F	0x00	ro	Unsigned32	Device capability
0x6380	0x00	ro	Unsigned8	VPRC set point
	0x01	rw	Integer16	Value
0x6381	0x00	ro	Unsigned8	VPRC actual value
	0x01	ro	Integer16	Value

CARATTERISTICHE / FEATURES

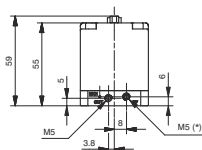

* = INGRESSO SEGNALE FEEDBACK ESTERNO
(PRESENTE SOLO NELLA
VERSIONE CON FEEDBACK ESTERNO)

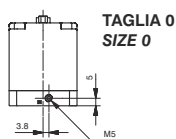
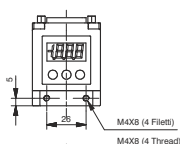

**TAGLIA 0
SIZE 0**

* = EXTERNAL FEEDBACK INPUT CONNECTION
(AVAILABLE ONLY ON THE
EXTERNAL FEEDBACK VERSION)

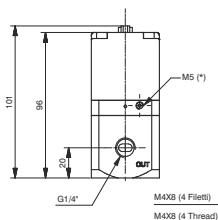

* = INGRESSO SEGNALE FEEDBACK ESTERNO
(PRESENTE SOLO NELLA
VERSIONE CON FEEDBACK ESTERNO)

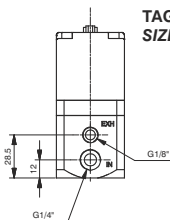
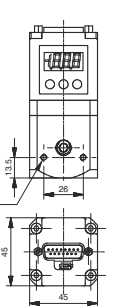

**TAGLIA 1
SIZE 1**

* = EXTERNAL FEEDBACK INPUT CONNECTION
(AVAILABLE ONLY ON THE
EXTERNAL FEEDBACK VERSION)

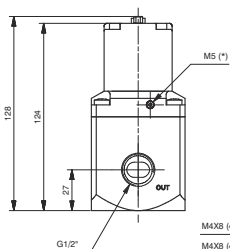

* = INGRESSO SEGNALE FEEDBACK ESTERNO
(PRESENTE SOLO NELLA
VERSIONE CON FEEDBACK ESTERNO)

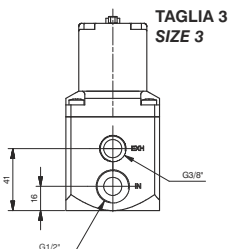
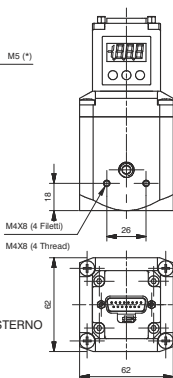

**TAGLIA 3
SIZE 3**

* = EXTERNAL FEEDBACK INPUT CONNECTION
(AVAILABLE ONLY ON THE
EXTERNAL FEEDBACK VERSION)

CARATTERISTICHE / FEATURES

Oltre alla possibilità di fissaggio diretto a parete mediante i fori da M4 presenti sul corpo, esiste la possibilità di utilizzare la squadretta di fissaggio codice 170M5 come si vede dalle figure sotto riportate.

In addition to the possibility of direct fixing on the wall using the M4 holes on the body the 170M5 fixing bracket can be used, as shown in the figures below.

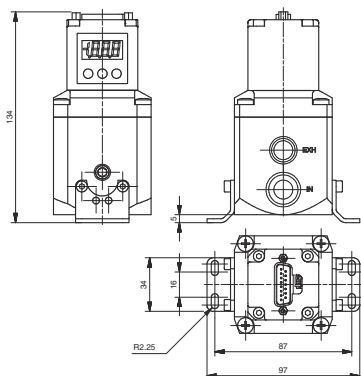
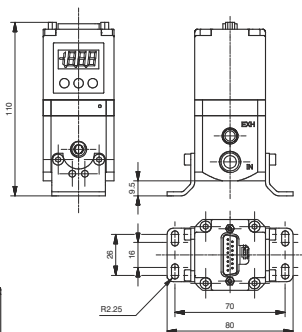
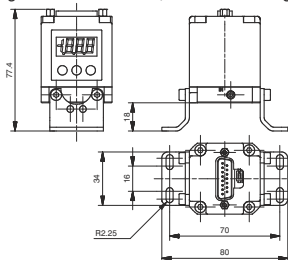

Struttura Codice / Code structure

17.E2N.S.C.



TAGLIA / SIZE :

- 0 = Taglia 0
Size 0
- 1 = Taglia 1
Size 1
- 3 = Taglia 3
Size 3

VARIANTE / VARIANT :

- Versione Standard
Standard version
- E = Feedback pressione esterna
External pressure feedback
- A = Scarico circuito in assenza di alimentazione elettrica
Exhaust downstream circuit without power supply
- AE = Variante A + Variante E
A Variant + E Variant

GAMMA PRESSIONI / PRESSURE RANGE:

- 0001 = Gamma 0 - 1 bar
Range 0 - 1 bar
- 0005 = Gamma 0 - 5 bar
Range 0 - 5 bar
- 0009 = Gamma 0 - 9 bar
Range 0 - 9 bar

Connettori elettrici / Electric connectors:

5300.F15.



VARIANTI / VARIANTS:

- 00 = Solo connettore + Guscio Ip65
Connector only + casing IP65
- 03 = Connettore + cavo 3 metri
Connector + cable, 3 metres
- 05 = Connettore + cavo 5 metri
Connector + cable, 5 metres

VERSIONE / VERSION :

- 00 = Diritto
Straight
- 90 = Uscita 90°
Output 90°

Squadretta di fissaggio / Fixing bracket :



170M5



Struttura Codice / Code structure

17 E2N. M . C .



TAGLIA / SIZE :

- 0 = Taglia 0
Size 0
- 1 = Taglia 1
Size 1
- 3 = Taglia 3
Size 3

VARIANTE / VARIANT :

- Versione Standard
Standard version
- E = Feedback pressione esterna
External pressure feedback
- A = Scarico circuito in assenza di alimentazione elettrica
Exhaust downstream circuit without power supply
- AE = Variante A + Variante E
A Variant + E Variant

GAMMA PRESSIONI / PRESSURE RANGE:

- 0001 = Gamma 0 - 1 bar
Range 0 - 1 bar
- 0005 = Gamma 0 - 5 bar
Range 0 - 5 bar
- 0009 = Gamma 0 - 9 bar
Range 0 - 9 bar

Nota / Note:

Questo modello non include la resistenza di terminazione
This model doesn't include the terminating resistor

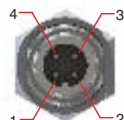

M12 4P MASCHIO
M12 4P MALE

PIN	DESCRIZIONE / DESCRIPTION
1	+24 VDC (NODO E INGRESSI) (NODE & INPUTS)
2	NC
3	GND
4	+24 VDC (USCITE) (OUTPUTS)

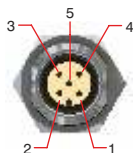

M12 5P FEMMINA
M12 5P FEMALE

PIN	SEGNALE SIGNAL	DESCRIZIONE DESCRIPTION
1	CAN_SHLD	Optional CAN Shield
2	CAN_V+	Optional CAN external positive supply (Dedicated for supply of transceiver and Optocouplers, if galvanic isolation of the bus node applies)
3	CAN_GND	Ground / 0V / V-
4	CAN_H	CAN_H bus line (dominant high)
5	CAN_L	CAN_L bus line (dominant low)