

Przyłączka kolankowa  
DIN 3905  
DIN 2353 typ K

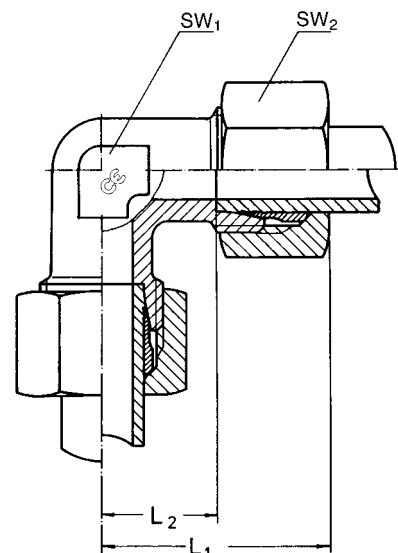

Seria DIN 2353	PN bar	Rura śr. zewnętrzna SW <sub>2</sub>		SW <sub>1</sub>	L <sub>1</sub>	L <sub>2</sub>	Kod	kg/100szt
KLL	100	4	10	9	21	11,0	W 4-LL	1,9
		6	12	9	21	9,5	W 6-LL	2,4
		8	14	12	23	11,5	W 8-LL	3,2
KL	315	6	14	12	27	12,0	W 6-L	4,2
		8	17	12	29	14,0	W 8-L	5,9
		10	19	14	30	15,0	W10-L	7,4
		12	22	17	32	17,0	W12-L	10,3
		15	27	19	36	21,0	W15-L	16,9
		18	32	24	40	23,5	W18-L	24,8
	160	22	36	27	44	27,5	W22-L	32,0
		28	41	36	47	30,5	W28-L	45,4
		35	50	41	56	34,5	W35-L	67,5
		42	60	50	63	40,0	W42-L	107,0
KS	630	6	17	12	31	16,0	W 6-S	7,4
		8	19	14	32	17,0	W 8-S	9,5
		10	22	17	34	17,5	W10-S	12,8
		12	24	17	38	21,5	W12-S	15,9
		14	27	19	40	22,0	W14-S	21,0
		400	16	30	24	43	24,5	W16-S
	20		36	27	48	26,5	W20-S	41,0
	25		46	36	54	30,0	W25-S	77,6
	30		50	41	62	35,5	W30-S	100,3
	315	38	60	50	72	41,0	W38-S	153,5

Wymiary są podane w przybliżeniu w zależności od stopnia dokręcenia nakrętek