

Przyłączka prosta gwintowana
gwint calowy z uszczelką miękką
DIN 3901
DIN 2353 typ D
gwint BSPP równoległy
uszczelnienie uszczelka miękką WD
typ E, wg DIN 3852-T 11
materiał (NBR, Viton)

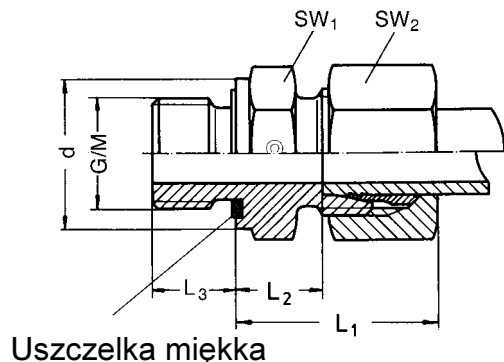

Seria DIN 2353	PN bar	Rura śr. zewn. G	ISO 1179-2/DIN ISO 228-1 gwint zewn.						d	Kod	kg/ 100szt
			SW_2	SW_1	L_1	L_2	L_3				
L	315	6	G 1/8 A	14	14	23	8,5	8	13,9	GE 6-LR 1/8-WD	2,5
		8	G 1/4 A	17	19	25	10,0	12	18,9	GE 8-LR 1/4-WD	4,5
		10	G 1/4 A	19	19	26	11,0	12	18,9	GE 10-LR 1/4-WD	4,7
		12	G 3/8 A	22	22	27	12,5	12	21,9	GE 12-LR 3/8-WD	6,9
		15	G 1/2 A	27	27	29	14,0	14	26,9	GE 15-LR 1/2-WD	11,5
		18	G 1/2 A	32	27	31	14,5	14	26,9	GE 18-LR 1/2-WD	13,2
	160	22	G 3/4 A	36	32	33	16,5	16	31,9	GE 22-LR 3/4-WD	18,5
		28	G 1 A	41	41	34	17,5	18	39,9	GE 28-LR 1 -WD	25,9
		35	G 1 1/4 A	50	50	39	17,5	20	49,9	GE 35-LR 1 3/4-WD	42,2
		42	G 1 1/2 A	60	55	42	19,0	22	54,9	GE 42-LR 1 1/2-WD	56,9
S	630	6	G 1/4 A	17	19	28	13,0	12	18,9	GE 6-SR 1/4-WD	5,0
		8	G 1/4 A	19	19	30	15,0	12	18,9	GE 8-SR 1/4-WD	5,5
		10	G 3/8 A	22	22	31	15,0	12	21,9	GE 10-SR 3/8-WD	8,8
		12	G 3/8 A	24	22	33	17,0	12	21,9	GE 12-SR 3/8-WD	10,0
		14	G 1/2 A	27	27	37	19,0	14	26,9	GE 14-SR 1/2-WD	14,8
	400	16	G 1/2 A	30	27	37	18,5	14	26,9	GE 16-SR 1/2-WD	16,1
		20	G 3/4 A	36	32	42	20,5	16	31,9	GE 20-SR 3/4-WD	25,3
		25	G 1 A	46	41	47	23,0	18	39,9	GE 25-SR 1 -WD	46,5
		30	G 1 1/4 A	50	50	50	23,5	20	49,9	GE 30-SR 1 1/4-WD	63,5
		315	38	G 1 1/2 A	60	55	57	26,0	22	54,9	GE 38-SR 1 1/2-WD

Seria DIN 2353	PN bar	Rura śr. zewn. G	ISO 9974-2/DIN 13 T5-7 gwint zewn.						d	Kod	kg/ 100szt
			SW_2	SW_1	L_1	L_2	L_3				
L	315	6	M 10x1	14	14	23	8,5	8	13,9	GE 6-LM 10x1,0-WD	2,5
		8	M 12x1,5	17	17	25	10,0	12	16,9	GE 8-LM 12x1,5-WD	4,0
		10	M 14x1,5	19	19	26	11,0	12	18,9	GE 10-LM 14x1,5-WD	4,9
		12	M 16x1,5	22	22	27	12,5	12	21,9	GE 12-LM 16x1,5-WD	6,8
		15	M 18x1,5	27	24	29	13,5	12	23,9	GE 15-LM 18x1,5-WD	9,5
		18	M 22x1,5	32	27	31	14,5	14	26,9	GE 18-LM 22x1,5-WD	13,7
	160	22	M 26x1,5	36	32	33	16,5	16	31,9	GE 22-LM 26x1,5-WD	18,8
		28	M 33x2	41	41	34	17,5	18	39,9	GE 28-LM 33x2,0-WD	25,8
		35	M 42x2	50	50	39	17,5	20	49,9	GE 35-LM 42x2,0-WD	42,0
		42	M 48x2	60	55	42	19,0	22	54,9	GE 42-LM 48x2,0-WD	57,5
S	630	6	M 12x1,5	17	17	28	13,0	12	16,9	GE 6-SM 12x1,5-WD	4,7
		8	M 14x1,5	19	19	30	15,0	12	18,9	GE 8-SM 14x1,5-WD	6,5
		10	M 16x1,5	22	22	31	15,0	12	21,9	GE 10-SM 16x1,5-WD	8,6
		12	M 18x1,5	24	24	33	17,0	12	23,9	GE 12-SM 18x1,5-WD	10,9
		14	M 20x1,5	27	27	37	19,0	14	25,9	GE 14-SM 20x1,5-WD	14,8
	400	16	M 22x1,5	30	27	37	18,5	14	26,9	GE 16-SM 22x1,5-WD	16,6
		20	M 27x2	36	32	42	20,5	16	31,9	GE 20-SM 27x2,0-WD	25,3
		25	M 33x2	46	41	47	23,0	18	39,9	GE 25-SM 33x2,0-WD	46,5
		30	M 42x2	50	50	50	23,5	20	49,9	GE 30-SM 42x2,0-WD	64,4
		315	38	M 48x2	60	55	57	26,0	22	54,9	GE 38-SM 48x2,0-WD

Wymiary są podane w przybliżeniu w zależności od stopnia dokręcenia nakrętek