

Przyłączka prosta gwintowana
gwint UNF, z o-ringiem NBR/viton
SAE J514
ANSI B 1.1-1982

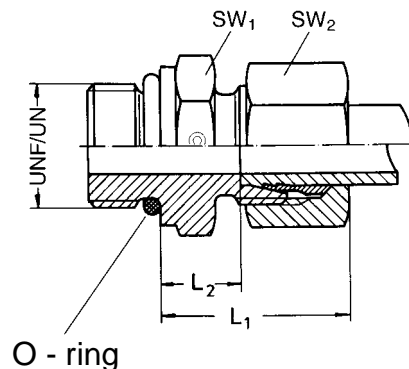

Seria DIN 2353	PN bar	Rura śr. zewn.	Gwint zewn. UNF/UN	SW ₂	SW ₁	L ₁	L ₂	Kod	kg/ 100szt	
L	315	6	7/16-20 UNF	14	17	25,0	10,0	GE 6-L 7/16-20 UNF	2,5	
		8	7/16-20 UNF	17	17	25,0	10,0	GE 8-L 7/16-20 UNF	3,6	
		10	7/16-20 UNF	17	19	26,0	11,0	GE 10-L 7/16-20 UNF	4,2	
		12	9/16-18 UNF	22	19	26,0	11,0	GE 12-L 9/16-18 UNF	5,6	
		12	3/4-16 UNF	22	24	28,0	13,0	GE 12-L 3/4-16 UNF	7,6	
		12	7/8-14 UNF	22	27	29,0	14,3	GE 12-L 7/8-14 UNF	10,1	
		15	3/4-16 UNF	27	24	29,0	14,0	GE 15-L 3/4-16 UNF	9,7	
		15	7/8-14 UNF	27	27	30,0	15,3	GE 15-L 7/8-14 UNF	12,0	
		18	3/4-16 UNF	32	27	31,0	14,5	GE 18-L 3/4-16 UNF	13,1	
	18	7/8-14 UNF	32	27	31,0	14,9	GE 18-L 7/8-14 UNF	13,7		
	160	22	7/8-14 UNF	36	32	33,0	16,8	GE 22-L 7/8-14 UNF	18,0	
		22	1 1/16-12 UN	36	32	33,0	16,5	GE 22-L 1 1/16-12 UN	18,8	
		22	1 5/16-12 UN	36	41	34,0	17,5	GE 22-L 1 5/16-12 UN	24,8	
		28	1 1/16-12 UN	41	41	34,0	17,5	GE 28-L 1 1/16-12 UN	25,2	
		28	1 5/16-12 UN	41	41	34,0	17,5	GE 28-L 1 5/16-12 UN	26,2	
		35	1 5/16-12 UN	50	46	39,0	17,5	GE 35-L 1 5/16-12 UN	37,6	
	S	630	8	7/16-20 UNF	19	17	30,0	15,0	GE 8-S 7/16-20 UNF	5,4
			10	9/16-18 UNF	22	19	31,0	14,5	GE 10-S 9/16-18 UNF	7,4
12			9/16-18 UNF	24	22	31,0	14,5	GE 12-S 9/16-18 UNF	8,6	
12			3/4-16 UNF	24	24	34,0	17,5	GE 12-S 3/4-16 UNF	10,9	
400		16	3/4-16 UNF	30	24	34,0	15,5	GE 16-S 3/4-16 UNF	13,5	
		16	7/8-14 UNF	30	27	37,0	18,8	GE 16-S 7/8-14 UNF	16,4	
		20	3/4-16 UNF	36	32	42,0	20,5	GE 20-S 3/4-16 UNF	24,0	
		20	7/8-14 UNF	36	32	42,0	20,8	GE 20-S 7/8-14 UNF	25,2	
		20	1 1/16-12 UN	36	32	42,0	20,5	GE 20-S 1 1/16-12 UN	26,0	
		25	1 1/16-12 UN	46	36	47,0	23,0	GE 25-S 1 1/16-12 UN	42,5	
		25	1 5/16-12 UN	50	46	50,0	23,5	GE 25-S 1 5/16-12 UN	47,7	
		30	1 5/16-12 UN	50	46	50,0	23,5	GE 30-S 1 5/16-12 UN	56,3	
30	1 5/8-12 UN	50	50	50,0	23,5	GE 30-S 1 5/8-12 UN	63,4			
315	38	1 5/8-12 UN	60	55	57,0	26,0	GE 38-S 1 5/8-12 UN	89,4		

Wymiary są podane w przybliżeniu w zależności od stopnia dokręcenia nakrętek
* Na zapytanie