

Przyłączka T gwintowana

DIN 3906

Gwinty:

całowy stożkowy

DIN 2353 typ N

metryczny stożkowy

DIN 2353 typ M

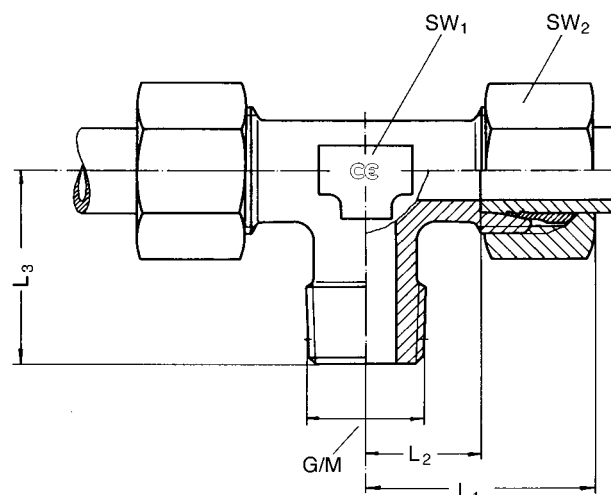

Seria DIN 2353	PN bar	Rura śr. zewn.	DIN 3858 gwint zewn. G	SW ₂	SW ₁	L ₁	L ₂	L ₃	Kod	kg/100szt
NLL	100	• 4	R 1/8 keg.	10	9	21	11,0	17	TE 4-LLR 1/8 keg.	2,6
		• 6	R 1/8 keg.	12	9	21	9,5	17	TE 6-LLR 1/8 keg.	3,6
		• 8	R 1/8 keg.	14	12	23	11,5	20	TE 8-LLR 1/8 keg.	4,2
NL	315	• 6	R 1/8 keg.	14	12	27	12,0	20	TE 6-LR 1/8 keg.	5,2
		• 8	R 1/4 keg.	17	12	29	14,0	26	TE 8-LR 1/4 keg.	7,2
		•10	R 1/4 keg.	19	17	30	15,0	27	TE 10-LR 1/4 keg.	9,3
		•12	R 3/8 keg.	22	17	32	17,0	28	TE 12-LR 3/8 keg.	13,9
		•15	R 1/2 keg.	27	19	36	21,0	34	TE 15-LR 1/2 keg.	20,1
		•18	R 1/2 keg.	32	24	40	23,5	36	TE 18-LR 1/2 keg.	29,6
NS	630 ¹⁾	• 6	R 1/4 keg.	17	12	31	16,0	26	TE 6-SR 1/4 keg.	10,1
		• 8	R 1/4 keg.	19	14	32	17,0	27	TE 8-SR 1/4 keg.	11,3
		•10	R 3/8 keg.	22	17	34	17,5	28	TE 10-SR 3/8 keg.	16,6
		•12	R 3/8 keg.	24	17	38	21,5	28	TE 12-SR 3/8 keg.	18,7
		•14	R 3/8 keg.	27	19	40	22,0	32	TE 14-SR 1/2 keg.	23,8
	400	•16	R 1/2 keg.	30	24	43	24,5	32	TE 16-SR 1/2 keg.	33,9

Seria DIN 2353	PN bar	Rura śr. zewn.	DIN 158 gwint zewn. M	SW ₂	SW ₁	L ₁	L ₂	L ₃	Kod	kg/ 100szt
MLL	100	• 4	M 8x1,0 keg.	10	9	21	11,0	17	TE 4-LLM 8x1 keg.	2,6
		• 6	M 10x1,0 keg.	12	9	21	9,5	17	TE 6-LLM 10x1 keg.	3,6
		• 8	M 10x1,0 keg.	14	12	23	11,5	20	TE 8-LLM 10x1 keg.	4,2
ML	315	• 6	M 10x1,0 keg.	14	12	27	12,0	20	TE 6-LM 10x1,0 keg.	5,2
		• 8	M 12x1,5 keg.	17	12	29	14,0	26	TE 8-LM 12x1,5 keg.	7,2
		•10	M 14x1,5 keg.	19	14	30	15,0	27	TE 10-LM 14x1,5 keg.	9,3
		•12	M 16x1,5 keg.	22	17	32	17,0	28	TE 12-LM 16x1,5 keg.	13,9
		•15	M 16x1,5 keg.	27	19	36	21,0	32	TE 15-LM 18x1,5 keg.	20,1
		•18	M 22x1,5 keg.	32	24	40	23,5	36	TE 18-LM 22x1,5 keg.	29,6
MS	630 ¹⁾	• 6	M 12x1,5 keg.	17	12	31	16,0	26	TE 6-LM 12x1,5 keg.	10,1
		• 8	M 14x1,5 keg.	19	14	32	17,0	27	TE 8-LM 14x1,5 keg.	11,3
		•10	M 16x1,5 keg.	22	17	34	17,5	28	TE 10-LM 16x1,5 keg.	16,6
		•12	M 18x1,5 keg.	24	17	38	21,5	28	TE 12-LM 18x1,5 keg.	18,7
		•14	M 20x1,5 keg.	27	19	40	22,0	32	TE 14-LM 20x1,5 keg.	23,8
	400	•16	M 22x1,5 keg.	30	24	43	24,5	32	TE 16-LM 22x1,5 keg.	33,9

¹⁾ Jeżeli gwint wkręcany jest w gwint wewnętrzny stożkowy to PN 630, w innym przypadku PN 400

Wymiary są podane w przybliżeniu w zależności od stopnia dokręcenia nakrętek

• Zgodnie z DIN 3906