

Przyłączka prosta
Gwint wewnętrzny metryczny

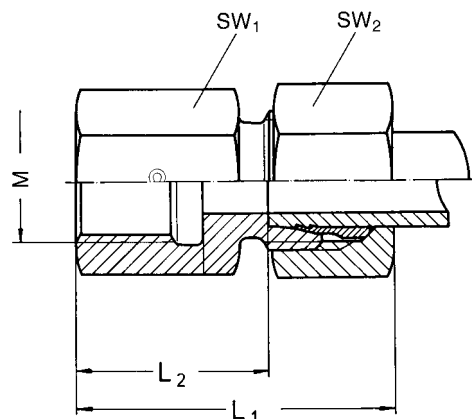

Seria DIN 2353	PN bar	Rura śr. zewn. M	DIN 13 T5-T7 gwint wewn. M	SW ₂	SW ₁	L ₁	L ₂	Kod	kg/100szt
L	315	6	M 10x1	14	14	34	19,5	GAI 6-LM 10x1	2,6
		8	M 12x1,5	17	17	39	24,0	GAI 8-LM 12x1,5	5,0
		10	M 14x1,5	19	19	40	25,0	GAI 10-LM 14x1,5	6,0
		12	M 16x1,5	22	22	41	26,0	GAI 12-LM 16x1,5	9,0
		12	M 18x1,5	22	24	41	26,0	GAI 12-LM 18x1,5	9,5
		12	M 20x1,5	22	27	43	28,0	GAI 12-LM 20x1,5	11,0
		15	M 18x1,5	27	24	43	28,0	GAI 15-LM 18x1,5	11,5
		18	M 22x1,5	32	30	46	29,5	GAI 18-LM 22x1,5	15,7
	160	22	M 26x1,5	36	32	51	34,5	GAI 22-LM 26x1,5	21,5
		28	M 33x2	41	41	54	37,5	GAI 28-LM 33x2	32,0
		35	M 42x2	50	55	62	40,5	GAI 35-LM 42x2	62,0
		42	M 48x2	60	60	65	42,0	GAI 42-LM 48x2	78,0
S	630	6	M 12x1,5	17	17	41	26,0	GAI 6-SM 12x1,5	5,4
		8	M 14x1,5	19	19	41	26,0	GAI 8-SM 14x1,5	6,9
		10	M 16x1,5	22	22	43	26,5	GAI 10-SM 16x1,5	10,2
		12	M 18x1,5	24	24	44	27,5	GAI 12-SM 18x1,5	11,0
		12	M 20x1,5	24	27	46	29,5	GAI 12-SM 20x1,5	12,5
		14	M 20x1,5	27	27	49	31,0	GAI 14-SM 20x1,5	14,8
	400	16	M 22x1,5	30	30	49	30,5	GAI 16-SM 22x1,5	17,5
		20	M 27x2	36	36	56	34,5	GAI 20-SM 27x2	30,7
		25	M 33x2	46	41	61	37,0	GAI 25-SM 33x2	46,6
		30	M 42x2	50	55	68	41,5	GAI 30-SM 42x2	76,5
	315	38	M 48x2	60	60	74	43,0	GAI 38-SM 48x2	92,0

Wymiary są podane w przybliżeniu w zależności od stopnia dokręcenia nakrętek