

Zawór zwrotny
z gwintami wewnętrznymi
ciśnienie otwarcia 1,0 bar (typ standardowy)
na zamówienie 0,5 ; 2,0 ; 3,0 bar

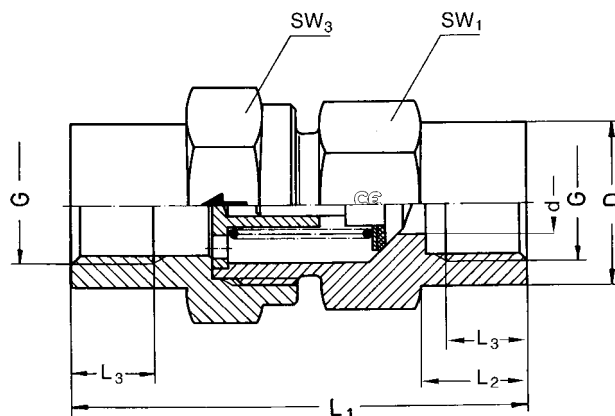

Seria DIN 2353	PN bar	Gwint wewn. G	SW ₁	SW ₃	L ₁	L ₃	L ₂	D	d	DN śr. przelotu	Kod	kg/ 100szt
S	400	G 1/8	19	19	42,5	8,0	12,0	19	3,5	3	RHDI R 1/8	8,5
		G 1/4	19	19	51,0	12,0	15,0	19	3,5	4	RHDI R 1/4	7,6
		G 3/8	24	27	50,0	12,0	15,0	24	7,5	8	RHDI R 3/8	15,6
		G 1/2	27	32	72,0	15,0	18,0	32	11,5	12	RHDI R 1/2	34,4
		G 3/4	41	46	84,0	16,5	22,0	41	15,0	16	RHDI R 3/4	59,0
	250	G 1	46	50	95,0	19,0	25,5	46	19,0	20	RHDI R1	82,3
		G 1 1/4	60	60	110,0	21,5	28,0	60	24,0	25	RHDI R1 1/4	156,6
		G 1 1/2	65	70	114,0	22,0	28,5	65	29,0	32	RHDI R1 1/2	193,3