

Handling

Quick installation guide



Caution

Any maintenance operation may only be carried out by qualified and authorized personnel. For any reason, do not reach into the pivoting range of the clamping arms, when the clamps are in operation. Disconnect and lock out pneumatic and electric supply lines before operating on or around clamps.

A worksheet for the right sizing of the clamp is available upon request. Visit our website for technical documents

<http://automotive.pneumax.it/>



Pressure operating range: from 2 to 8 bar/ from 30 to 115 psi.
Inline lubrication isn't required: if lubricated air is used, it is necessary to continue using lubricated air, as the oil in it may have removed the basic lubrication in the device.

HANDLING

The clamp is warranted for 3 mln cycles in correct operating conditions

No lubrication.

No preventive maintenance.

External cleaning with non-corrosive detergents is required: cleaning interval depends on the ambient conditions as well as on the frequency of use.



Clamp installation to the tool

The gripper clamp can be installed by one of its four mounting surfaces, using dowels and screws according to its datasheet. The tightening torques to be set are:

M6 10 N m / 7.37 lb-ft

Use the key support surfaces, where available.
Always use all the bores on the mounting pattern.

Clamping jaws mount

The sides of the brackets have two different heights. Assemble the brackets to the side of the clamping arm, so that the surfaces, where the side mark has been machined on, will match. Secure, at first, the screw on the mark side **1** by setting the tightening torques to 22 N m /16.22 lb-ft and leave no gap between the bracket and the jaws. Then, secure the other screw **2**: in this case, due to the different length of the sides of the brackets, a gap between the same and the clamping arm will be noticed. Always use locking washers. Please refer to the clamping arms' datasheet for possible clamping arm position and the respective max opening angle.

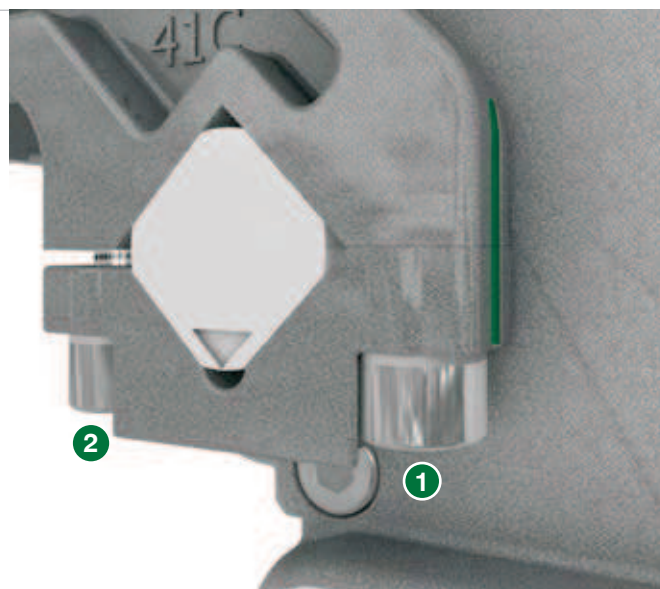

Opening angle adjustment

The jaws must be in the open position. Insert a 5 mm hexagonal flat Allen Wrench or a screw gun and adjust the opening position to the required opening angle.

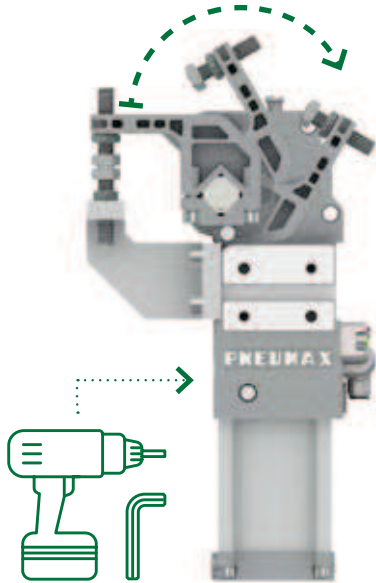

Visit our website for a video of the adjustment procedure. **No adjustment of the sensor is required.**

One access point to opening angle adjustment on each side

Manual release button

To manually unlock the mechanism, hit the bolt with a rubber mallet. The linkage will automatically release itself from the over-centre position. To close the clamps during set-up operations, without air, use a screw gun or a flat Allen wrench to engage the adjustment means and adjust the clamp till 0° opening angle: the linkage will be toggle-locked as the manual release button is completely outside. The J40D and the JK40D series are equipped with a handlever, with whom the clamp can be closed and opened.

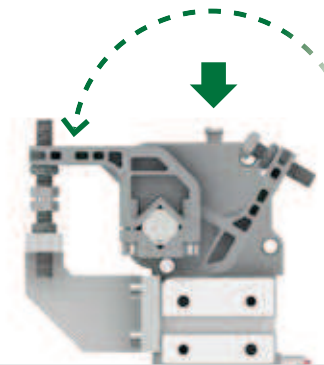

Adjustment Of the tips

Adjust the lower tips at a predetermined position and place the metal sheet to be held. For an optimal holding of the workpiece, adjust the tips on the mobile arm until contact with the workpiece is reached. Open and close the clamp. After a proper adjustment to get the required clamping force has been accomplished, secure the tip screws by tightening the bolts. Tips with different holding surfaces are available upon request.

Electronic sensor

ES001 is used for all clamps' sizes and series. Stepless adjustment of the connector: unscrew the tightening screw and set the connector in the required position, then secure the screw with 5 N m / 3.68 lb-ft.

To replace the sensor, remove the M5 screw and assemble a new one by tightening the same screw with 5 N m / 3.68 lb-ft.



Technical features	
Operating voltage	10-30 VDC
Voltage drop	≤ 2 V
Load current	≤ 100 mA
Current consumption	≤ 30 mA
Short-circuit protection	protected
Protection rating	IP68
Operating temperature	-0 °C +50 °C
Storage temperature	-25 °C +60 °C
Electromagnetic compatibility	EN 60947-5-2:2007 + A1:2012
Power supply indication	green LED
Open position indication	yellow LED
Closed position indication	red LED
Digital output type	PNP

