

REGULATORS

The Pneumax range of regulators include high precision manual regulators and electronic proportional pressure regulators air-vacuum or vacuum-vacuum versions, available in 3 sizes with flow rates of 7; 1.100 or 4.000 NI/min.

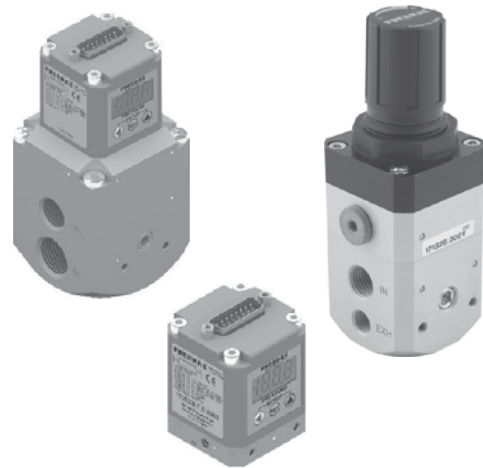

Index

Manual regulator



Series 1700

115

Proportional regulators

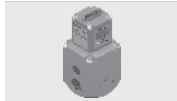

Series 1900
Air-vacuum versions

117



Series 1900
Vacuum-vacuum version

122

Manual regulator Series 1700



Vacuum degree regulation for applications requiring high stability and accuracy.

It have the function of regulating the negative vacuum pressure, keeping it stable at set value regardless of flow and variations in the degree of vacuum in the primary network. The units are of a double diaphragm construction and have been designed to exploit to their advantage any existing pressure differential between the

secondary depression and atmospheric pressure. The degree of vacuum is obtained by rotating the adjusting knob, rotating it clockwise to increase the amount of vacuum and anti clockwise to decrease it. They are used in all centralized systems where regardless of the vacuum in the main network a lower vacuum level is required for other applications.

Regulator for vacuum

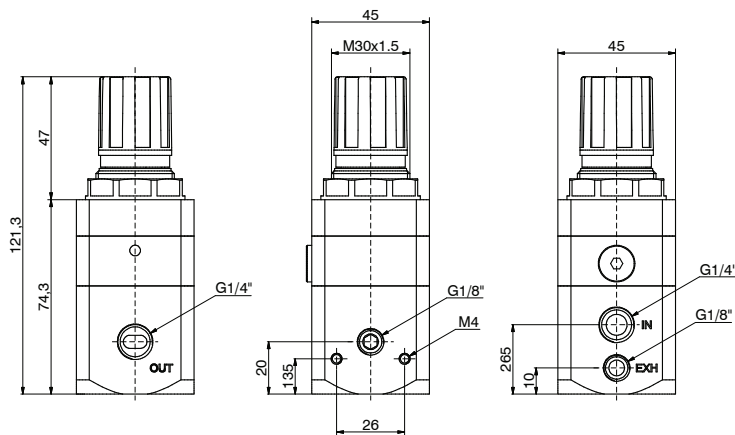

Ordering code
171S2B000V

Example: 171S2B000V
Regulator for vacuum G1/4"

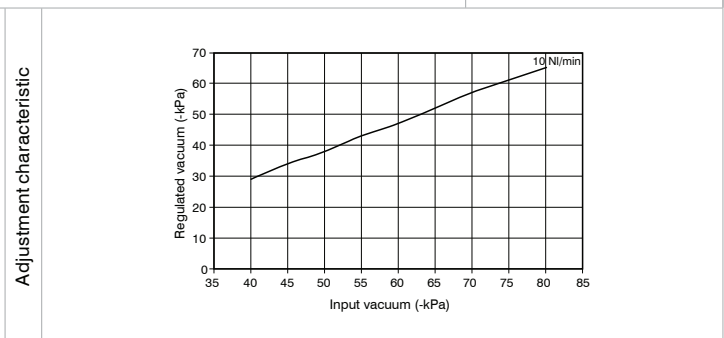
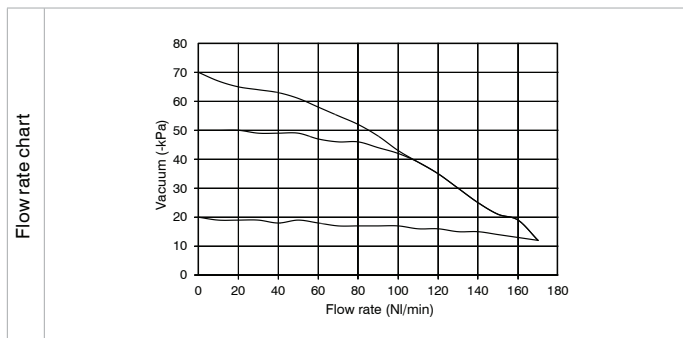

Construction characteristics
- Precision in keeping the set pressure value.
- Sensitivity combined with high flow rate of the downstream overpressure discharge valve.
- High flow rate with very low pressure drop.
- Setting knob can be locked using pressure into the desired position.
- Body made of light alloy.
- Two attachments for vacuum gauge with a cap equipped with a gasket.
- Ring nut for panel mounting.
- Once the reducer has been placed under vacuum, air intake through the appropriate orifice.

Technical characteristics	
Connections	G1/4"
Max. working pressure (kPa)	101
Working temperature °C	-5 ... +50
Pressure gauge connections	G1/8"
Weight (gr.)	400
Mounting position	indifferent
Max. fitting torque (Nm)	25
Fluid	Filtered air 20µm
Diameter of panel mounting orifice (mm)	30

Proportional regulators Series 1900

Electronic proportional pressure regulator with closed Loop.
Air-vacuum and vacuum-vacuum versions.

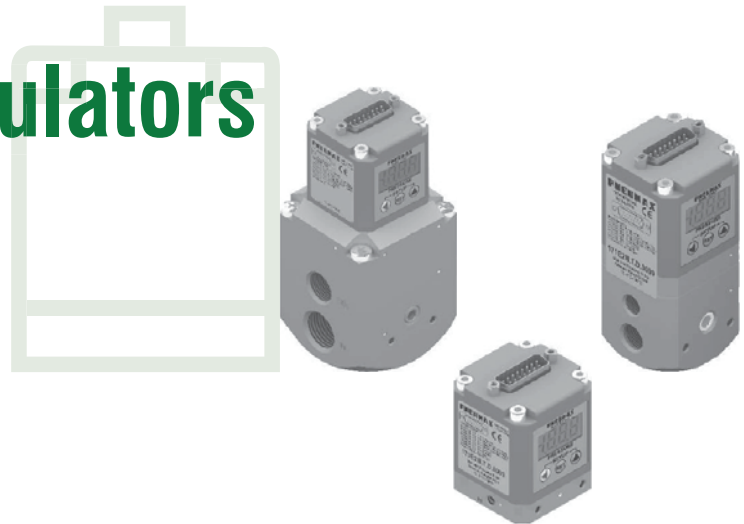

Modern industrial applications require increasingly high performances from their pneumatic components. For example, the speed and thrust of a pneumatic cylinder, or the torque of a rotary actuator may need to be varied. These parameters often need to be modified dynamically while an operation is running.

This solution can be obtained by employing a proportional pressure regulator Series 1700 available in 3 sizes with flow rates of 7; 1.100 or 4.000 Nl/min.

The model that manage the positive pressure that controls a vacuum generator and the negative pressure are then added to this range.

Application fields

Typical applications will include the necessity to dynamically control the force of an actuator, be it thrust or torque or the degree of vacuum. Examples include: closing systems, painting systems, tensioning systems, packaging systems, pneumatic braking systems, force control for welding grippers, thickness compensation systems, balancing systems, laser cutting, pressure transducers for the control of modulating valves, test benches for system testing, force control for buffers on polishers, management of force exerted by suction cups in handling applications and management of the force exerted by the vacuum in the autoclaves.

Series 1900 air-vacuum version

Product description

The pneumatic connections of the regulator require the aperture for supply and discharge to be on one side and the aperture for use on the opposite side. On the other two remaining sides there are apertures of G1/8" that are plugged up with removable plugs, however it is possible to connect a pressure gauge through them or use the connections as outputs. On the side where the service connection is, there is an M5 aperture where you can connect the return vacuum signal (to the pressure transducer). This option makes it possible to pick up the signal from a remote point rather than directly from the service connection. In the upper part of regulators there are control solenoid valves, the pressure sensor and the electronics for control. The part for electronically controlling the regulators is the same for all the 3 sizes. The new range of proportional regulators is supplied as standard with all the functionality initially considered only as optional; the only selections necessary in the ordering phase are thus related to the type of signal for control of voltage (T) or current (C) and the range of working pressures.

Functional diagram

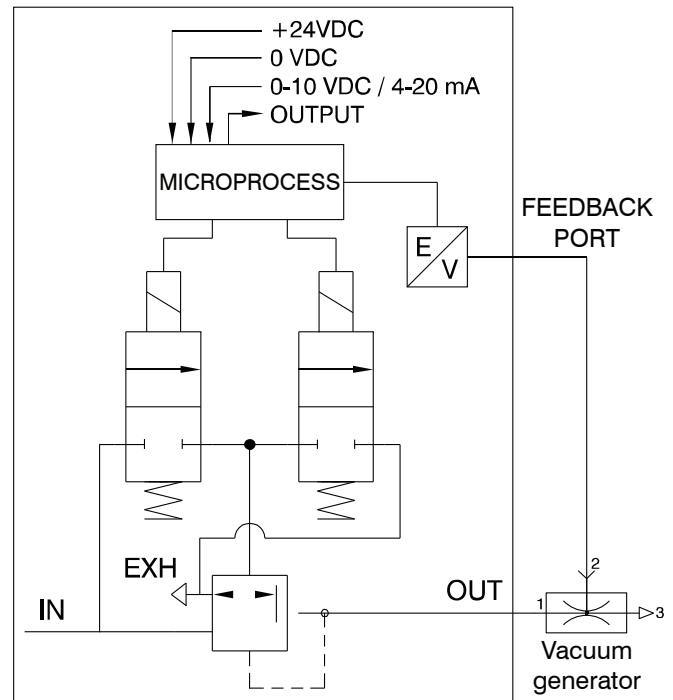

CLOSED LOOP diagram (internal control circuit)

The proportional regulator is known as a CLOSED LOOP regulator because a pressure transducer in the circuit transmits a continuous analog signal to the microprocessor, which compares the reference value with the detected value and supplies the control solenoid valves accordingly.

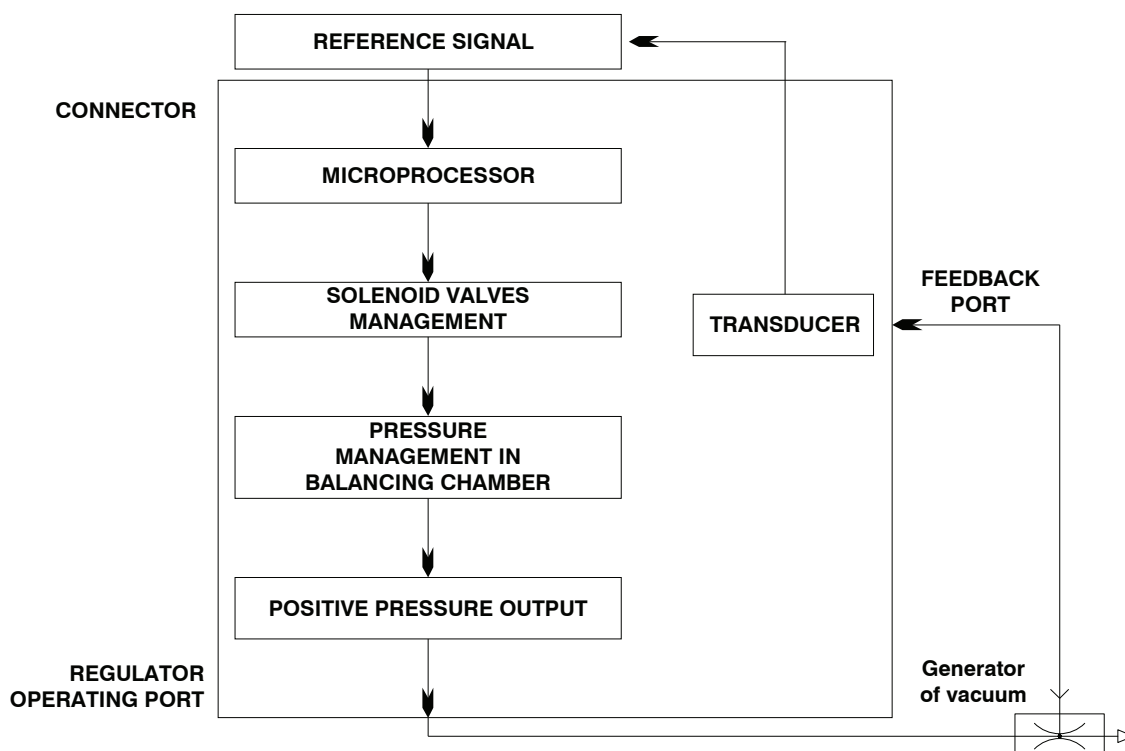



CHARACTERISTICS

Pneumatic

Fluid	5 micron filtered and dehumidified air		
Input minimum pressure	As a function of the type of vacuum generator		
Input max pressure	10 bar		
Output pressure	0 ... 9 bar		
Nominal flow rate from 1 to 2 (6 bar Δp 1 bar)	Size 0	Size 1	Size 3
	7 NI /min	1.100 NI /min	4.000 NI/min
Discharge flow rate (at 6 bar with overpressure of 1 bar)	7 NI /min	1.300 NI /min	4.500 NI/min
Air consumption	< 1 NI/min	< 1 NI/min	< 1 NI/min
Supply connection	M5	G1/4"	G1/2"
Service connection	M5	G1/4"	G1/2"
Discharge connection	Ø1,8	G1/8"	G3/8"
Maximum tightening torque for connections	3 Nm	15 Nm	15 Nm

Electric

Supply voltage	24VDC \pm 10% (stabilized with ripple < 1%)		
Current consumption in standby	70mA		
Current consumption with actuated S.V.	400mA		
**Reference signal	Voltage	*0 ... 10 V *0 ... 5 V *1 ... 5 V	
	Current	*4 ... 20 mA *0 ... 20 mA	
**Input impedance	Voltage	10 k Ω	
	Current	250 Ω	
**Digital inputs	24VDC \pm 10%		
**Digital output	24 VDC PNP (max current 50 mA)		

Functional

Linearity	\pm Insensitivity
Hysteresis	\pm Insensitivity
Repeatability	\pm Insensitivity
Sensitivity	0,01 bar
Assembly position	Indifferent
IP Rating	IP65 (with casing fitted)
Ambient temperature	-5° ... 50° / 23°F ... 122°F

Constructional

Body	Anodised aluminum		
Shutters	Brass with vulcanised NBR		
Diaphragm	Cloth-covered rubber		
Seals	NBR		
Cover for electrical part	Technopolymer		
Springs	AISI 302		
Weight	Size 0	Size 1	Size 3
	168 gr.	360 gr.	850 gr.

* Selectable by keyboard or by RS-232

** Valid only for devices with analog input

SIZE 0

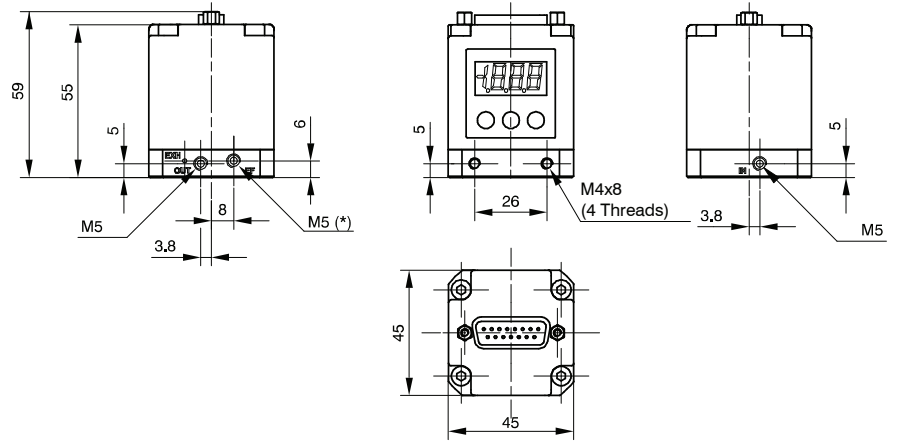

* EXTERNAL FEEDBACK INPUT CONNECTION

SIZE 1

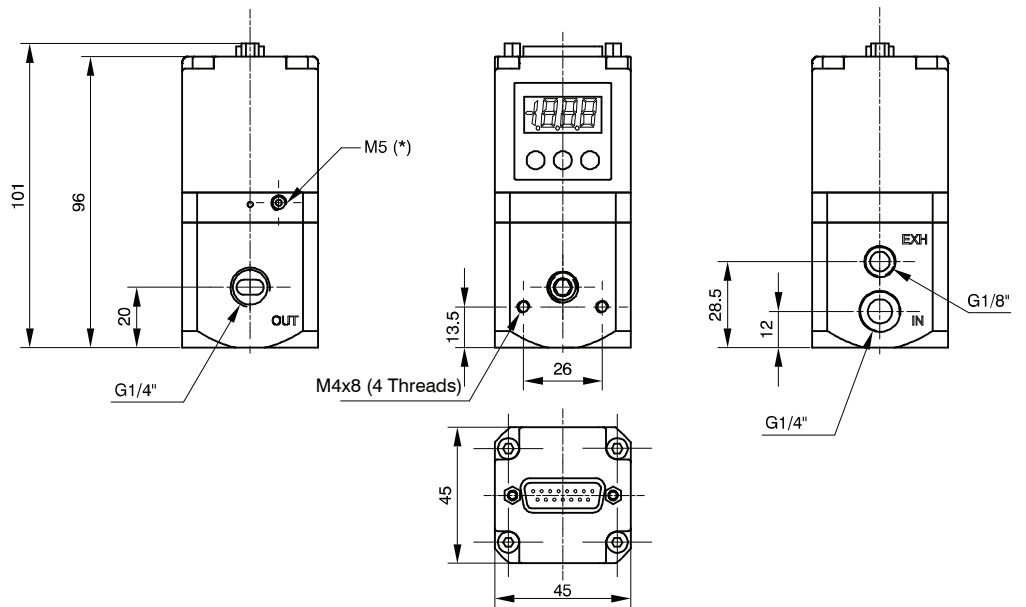

* EXTERNAL FEEDBACK INPUT CONNECTION

SIZE 3

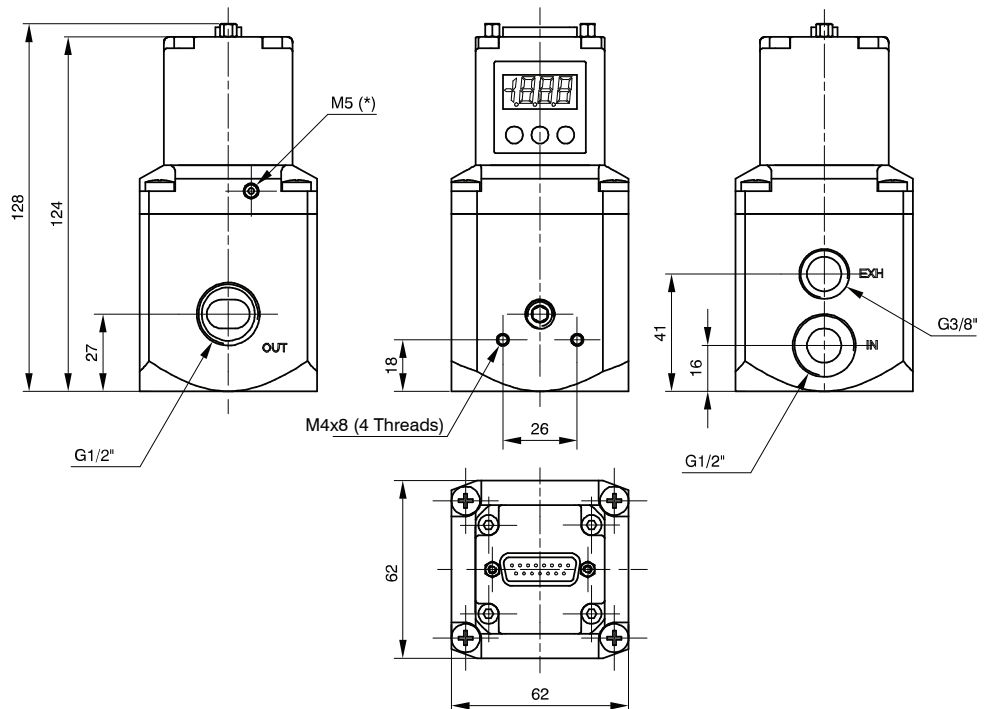

* EXTERNAL FEEDBACK INPUT CONNECTION

Mounting options

In addition to the possibility of fastening it directly to the wall using the M4 apertures present on the body, there is also the option of using the fastening bracket code 170M5 as can be seen in the figures shown below.

► SIZE 0

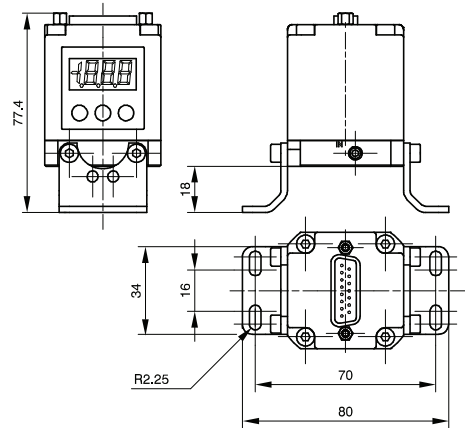

* EXTERNAL FEEDBACK INPUT CONNECTION

► SIZE 1

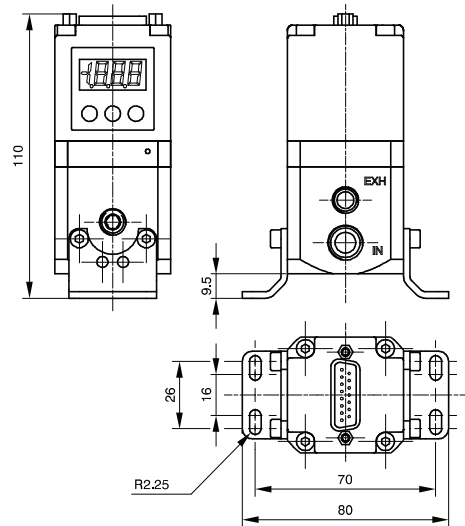

* EXTERNAL FEEDBACK INPUT CONNECTION

► SIZE 3

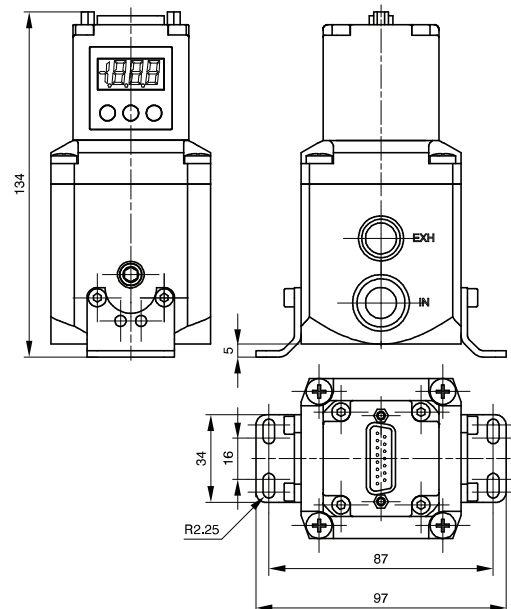

* EXTERNAL FEEDBACK INPUT CONNECTION

Installation/ Operation



PNEUMATIC CONNECTION

The compressed air is connected by means of M5 threaded holes (for size 0 regulators), G 1/4" threaded holes (for size 1 regulators) and G 1/2" threaded holes (for size 3 regulators) on the body.
Before making the connections, eliminate any impurities in the connecting pipes to prevent chippings or dust entering the unit.
Do not supply the circuit with more than 10 bar pressure and make sure that the compressed air is dried (excessive condensate could cause the appliance to malfunction) and filtered at 5 micron. The minimum supply pressure required depends on the characteristics of the vacuum generator.
If a silencer is applied to the discharge path the unit response time may change; periodically check that the silencer is not blocked and replace it if necessary.



ELECTRICAL CONNECTION

For the electrical connection a SUB-D 15-pole female is used.
Wire in accordance with the wiring diagram shown below.

Warning: INCORRECT CONNECTIONS MAY DAMAGE THE DEVICE



NOTES ON OPERATION

If the electric supply is interrupted, the outlet pressure is maintained at the set value. However, maintaining the exact value cannot be ensured as it is impossible to operate the solenoid valves.
In order to discharge the circuit downstream, zero the reference, make sure that the display shows a pressure value equal to zero and then disconnect the electric power supply.
A version of the device is available that exhausts the downstream circuit when the power supply is removed. (Option "A" at the end of the ordering code). If the compressed-air supply is suspended and the electric power supply is maintained a whirring will be heard that is due to the solenoid valves; an operating parameter can be activated (P18) that triggers the regulator protection whenever the requested pressure is not reached within 4 seconds of the reference signal being sent. In this case the system will intervene to interrupt the control of the solenoid valves. Every twenty seconds, the unit will start the reset procedure until standard operating conditions have been restored.

TOP VIEW OF THE REGULATOR CONNECTOR

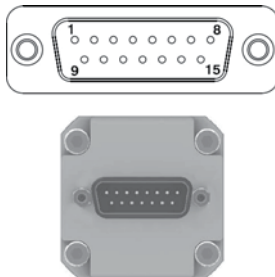

CONNECTOR PIN:	
1	DIGITAL INPUT 1
2	DIGITAL INPUT 2
3	DIGITAL INPUT 3
4	DIGITAL INPUT 4
5	DIGITAL INPUT 5
6	DIGITAL INPUT 6
7	DIGITAL INPUT 7
8	ANALOG INPUT / DIGITAL INPUT 8
9	SUPPLY (24 VDC)
10	DIGITAL OUTPUT (24 VDC PNP)
11	ANALOG OUTPUT (CURRENT)
12	ANALOG OUTPUT (VOLTAGE)
13	Rx RS-232
14	Tx RS-232
15	GND

Ordering codes



19 E2P D.0090.

SIZE
0 = Size 0
1 = Size 1
3 = Size 3

VARIANT
E = External pressure feedback without exhaust downstream pressure when power supply is removed
AE = External pressure feedback with exhaust downstream pressure when power supply is removed

MANAGEMENT
C = Current signal (4-20 mA / 0-20 mA)
T = Voltage signal (0-10 V / 0-5 V / 1-5 V)



PRESSURE RANGE
0090 = from 0 to 90%

Model with SUB-D 15 poles connector

	5300.F15.00.00	Straight connector + Casing IP65 *
	5300.F15.00.03	Straight connector + Cable 3 meters
	5300.F15.00.05	Straight connector + Cable 5 meters
	5300.F15.90.00	Connector 90° + Casing IP65 *
	5300.F15.90.03	Connector 90° + Cable 3 meters
	5300.F15.90.05	Connector 90° + Cable 5 meters

* Without cable

REGULATORS

Series 1900 vacuum-vacuum version

Product description

The connections of the regulator require the aperture for supply and discharge to be on one side and the aperture for use on the opposite side. On the other two remaining sides there are apertures of G1/8" that are plugged with removable plugs, however it is possible to connect a vacuum gauge or vacuum sampling for an additional remote vacuum switch. The control solenoid valves, the negative pressure sensor and the management electronics are located in the upper part of the regulator. The regulator is available in only one size, 1, with flow rate 170 l/min and the possibility to select commands: Voltage (T) Current (C).

Functional diagram

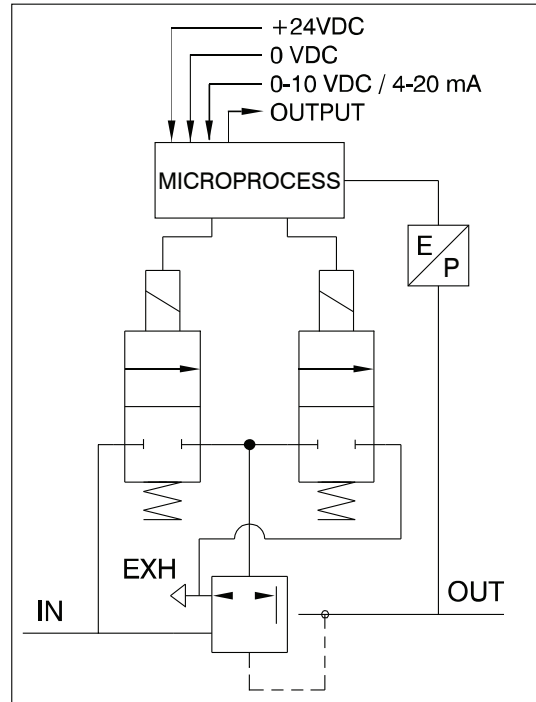

CLOSED LOOP diagram (internal control circuit)

The proportional regulator is known as a CLOSED LOOP regulator because a pressure transducer in the circuit transmits a continuous analog signal to the microprocessor, which compares the reference value with the detected value and supplies the control solenoid valves accordingly.

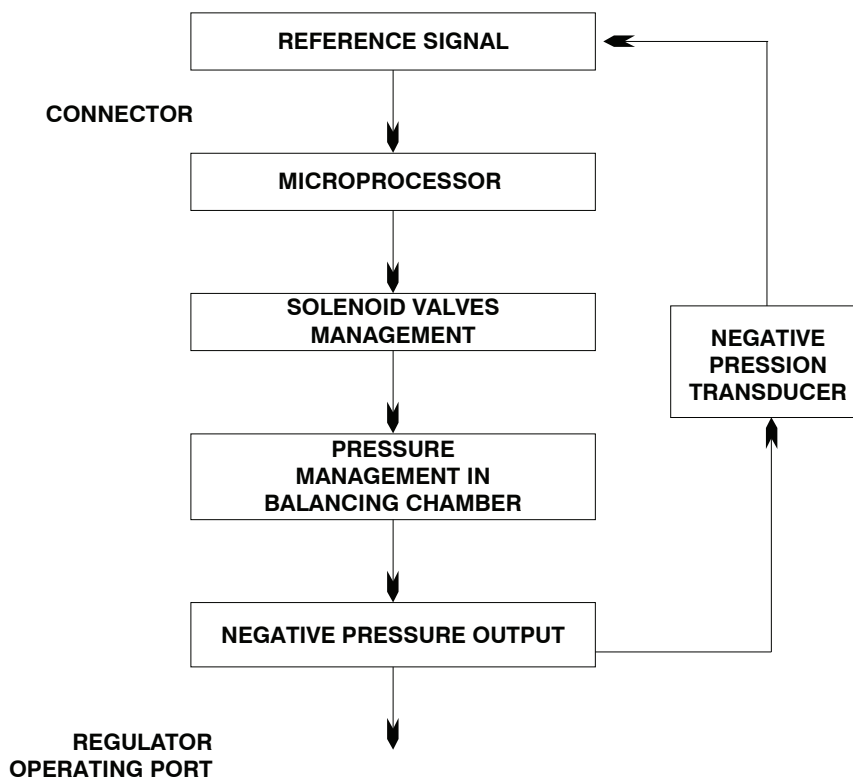



CHARACTERISTICS

Pneumatic

Fluid	5 micron filtered and dehumidified air
Input minimum pressure	10 -kPa
Input max pressure	101 -kPa
Adjustment range	10 ... 90 -kPa
Flow rate	170 l/min
Air consumption	< 1 NI/min
Supply connection	G 1/4"
Service connection	G 1/4"
Discharge connection	G 1/8"
Maximum tightening torque for connections	15 Nm

Electric

Supply voltage	24VDC \pm 10% (stabilized with ripple<1%)	
Current consumption in standby	70mA	
Current consumption with actuated S.V.	400mA	
**Reference Signal	Voltage	*0 ... 10 V *0 ... 5 V *1 ... 5 V
	Current	*4 ... 20 mA *0 ... 20 mA
**Input impedance	Voltage	10 k Ω
	Current	250 Ω
**Digital inputs	24VDC \pm 10%	
**Digital output	24 VDC PNP (max current 50 mA)	

Functional

Linearity	\pm Insensitivity
Hysteresis	\pm Insensitivity
Repeatability	\pm Insensitivity
Sensitivity	0,01 bar
Assembly position	Indifferent
IP Rating	IP65 (with casing fitted)
Ambient temperature	-5° ... 50° / 23°F ... 122°F

Constructional

Body	Anodised aluminum
Shutters	Brass with vulcanised NBR
Diaphragm	Cloth-covered rubber
Seals	NBR
Cover for electrical part	Technopolymer
Springs	AISI 302
Weight	Size 1
	360 gr.

* Selectable by keyboard or by RS-232

** Valid only for devices with analog input

► SIZE 1

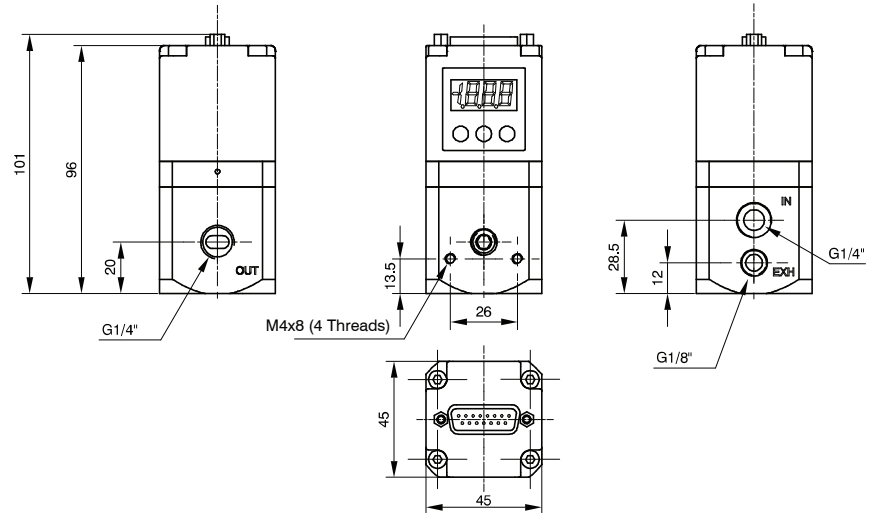

Mounting options

In addition to the possibility of fastening it directly to the wall using the M4 apertures present on the body, there is also the option of using the fastening bracket code 170M5 as can be seen in the figures shown below.

► SIZE 1

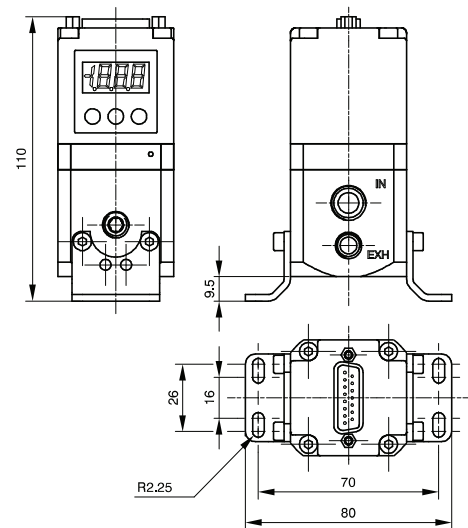

Installation/ Operation



PNEUMATIC CONNECTION

The compressed air is connected by means of M5 threaded holes (for size 0 regulators), G 1/4" threaded holes (for size 1 regulators) and G 1/2" threaded holes (for size 3 regulators) on the body.
Before making the connections, eliminate any impurities in the connecting pipes to prevent chippings or dust entering the unit.
Do not supply the circuit with more than 10 bar pressure and make sure that the compressed air is dried (excessive condensate could cause the appliance to malfunction) and filtered at 5 micron. The minimum supply pressure required depends on the characteristics of the vacuum generator.
If a silencer is applied to the discharge path the unit response time may change; periodically check that the silencer is not blocked and replace it if necessary.



ELECTRICAL CONNECTION

For the electrical connection a SUB-D 15-pole female is used.
Wire in accordance with the wiring diagram shown below.

Warning: INCORRECT CONNECTIONS MAY DAMAGE THE DEVICE



NOTES ON OPERATION

If the electricity supply is cut off, the output pressure will be kept at the set value. However, maintenance of this exact value is not guaranteed given the fact that the solenoid valve cannot be actuated.
To discharge the circuit downstream, clear the reference, make sure the display shows a pressure value equal to zero, and then cut off the electrical power supply.
A version of the device is available as an option that discharges the circuit downstream right at the time the electricity is cut off (final letter A in the ordering code). If the air supply is stopped and the power supply is maintained, you may hear a humming noise being generated due to the solenoids; it is possible to activate an operating parameter (P18) that allows the regulator to be protected any time the pressure is not reached within 4 seconds after the moment the reference signal is sent. In this case, the system will intervene by interrupting control of the solenoid valves. Every 20 seconds the unit will start the restoration procedure until standard operating conditions are reintegrated.

TOP VIEW OF THE REGULATOR CONNECTOR

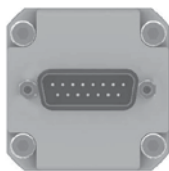
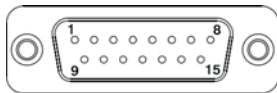

CONNECTOR PIN:	
1	DIGITAL INPUT 1
2	DIGITAL INPUT 2
3	DIGITAL INPUT 3
4	DIGITAL INPUT 4
5	DIGITAL INPUT 5
6	DIGITAL INPUT 6
7	DIGITAL INPUT 7
8	ANALOG INPUT / DIGITAL INPUT 8
9	SUPPLY (24 VDC)
10	DIGITAL OUTPUT (24 VDC PNP)
11	ANALOG OUTPUT (CURRENT)
12	ANALOG OUTPUT (VOLTAGE)
13	Rx RS-232
14	Tx RS-232
15	GND

Ordering codes



191E2N. .D.0000.V

MANAGEMENT

- C = Current signal (4-20 mA / 0-20 mA)
- T = Voltage signal (0-10 V / 0-5 V / 1-5 V)

PRESSURE RANGE

0000 = from 10 to 90 -kPa

**Fixing bracket
170M5**



Model with SUB-D 15 poles connector

	5300.F15.00.00	Straight connector + Casing IP65 *
	5300.F15.00.03	Straight connector + Cable 3 meters
	5300.F15.00.05	Straight connector + Cable 5 meters
	5300.F15.90.00	Connector 90° + Casing IP65 *
	5300.F15.90.03	Connector 90° + Cable 3 meters
	5300.F15.90.05	Connector 90° + Cable 5 meters

* Without cable

REGULATORS