

▶ Panel mounting pressure regulator including pressure gauge

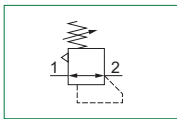

- ▶ Diaphragm pressure regulator with relieving
- ▶ Balanced poppet
- ▶ Technopolymer body with aluminum reinforced threaded connections
- ▶ Pressure adjusting lockable handle by simply pressing it downwards in the desired position
- ▶ Including pressure gauge integrated on the knob
- ▶ Ring nut for panel mounting
- ▶ Atex certification (II 3GD) on request



Technical characteristics	Size
	Size 1
Body and connections type	Technopolymer body, aluminum reinforced threaded connections
IN / OUT connections	G1/8" - G1/4"
Assembly configuration	Stand alone Panel mounting With fixing bracket
Assembly position	Indifferent
Pressure range (bar)	0 - 2 / 0 - 4 / 0 - 8 / 0 - 12
Regulation	Manual push and lock with pressure
Pressure measurement	G1/8" Pressure gauge connection port integrated on the knob
Max. fittings torque IN / OUT connections	G1/8" metal: 15 G1/4" metal: 20

Operational characteristics	Size
	Size 1
Maximum working pressure (bar)	13
Minimum working pressure (bar)	0,5
Working temperature (°C)	-5 ÷ +50

Weights	Size
	Size 1
Technopolymer body version (g)	250

**Order codes**

17 129A . D

**Size, body and connections**

129A : Technopolymer body, connections G1/8"

129B : Technopolymer body, connections G1/4"

**Pressure range**

A : 0 - 2 bar

B : 0 - 4 bar

C : 0 - 8 bar

D : 0 - 12 bar

**Example: 17129A.D**

Size 1 panel mounting pressure regulator including pressure gauge, technopolymer body, G1/8" connections, 0 - 12 bar

**2 Dimensions**

AIR TREATMENT

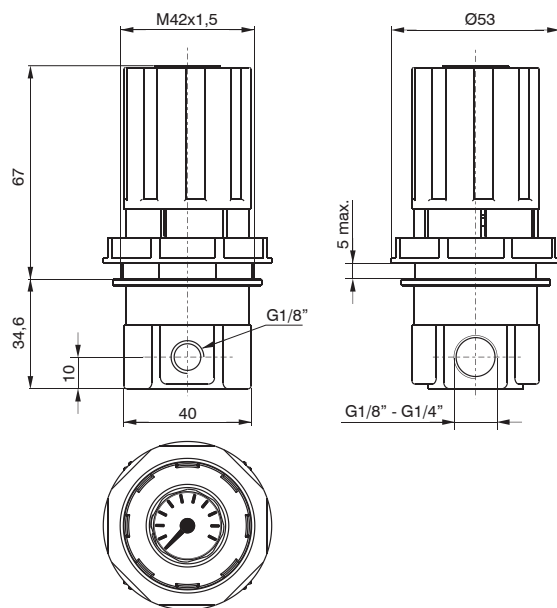

Size 1

**Characteristic curves**

