

► **Fixing bracket for regulators**

**1725 0**

<b>Size</b>
1725 : Size 2
1735 : Size 3

<b>Type</b>
0 : For standard regulators
2 : For pressure regulators

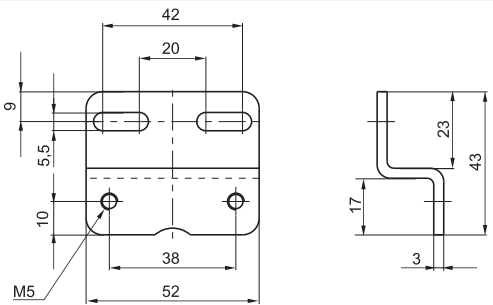

**Size 2**

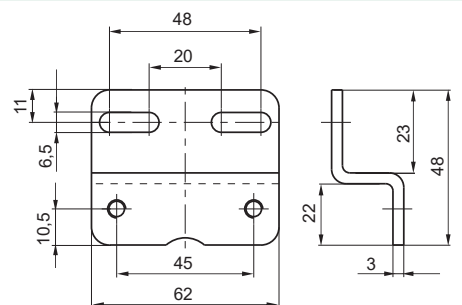

**Size 3**

► **Fixing bracket**

**171 50**

<b>Size</b>
171 : Size 1
T172 : Size 2 - Size 3

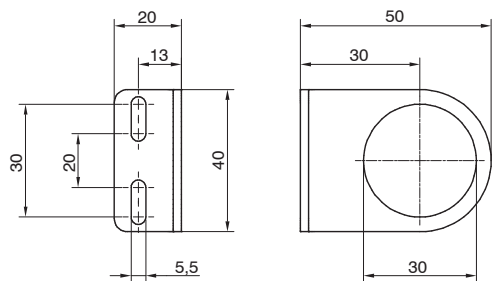

**Size 1**

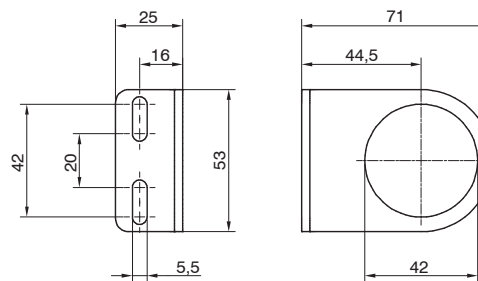

**Size 2 - TG3**

► **Fixing bracket**

**170 M5**

<b>Size</b>
170 : Size 1

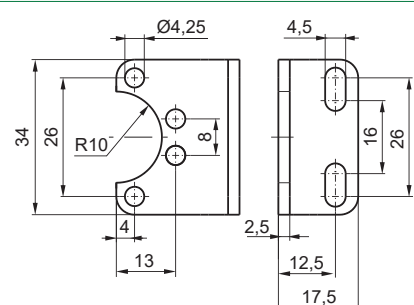

**Size 1**

2  
AIR TREATMENT

► Fixing bracket for pressure regulator

<b>Size</b>
170 : Size 1

170 50

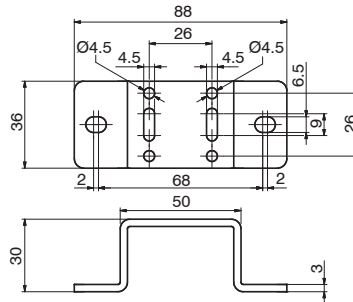

Size 1

► Pressure gauge

<b>Versione</b>
A : Dial Ø40
B : Dial Ø50

<b>Scala</b>
A : 0 - 4 bar
B : 0 - 6 bar
C : 0 - 12 bar

17070

A C

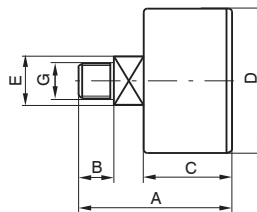

DIMENSIONS

CODE	A	B	C	D	E	G	Weight g
17070A	44	10	26	41	14	1/8"	60
17070B	45	10	27	49	14	1/8"	80

► Pressure gauge diameter Ø23

<b>Scala</b>
A : 0 - 4 bar
B : 0 - 6 bar
C : 0 - 12 bar

17070M A

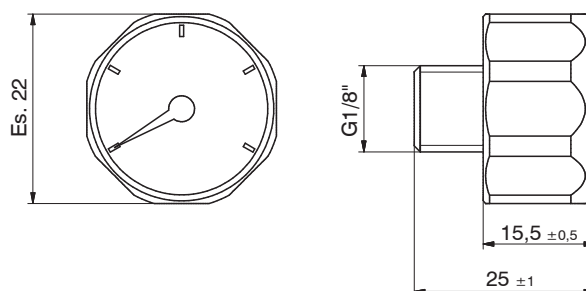

► **Assembling kit**

1726 0

<b>Size</b>
1716 : Size 1
1726 : Size 2
1736 : Size 3
1746 : Size 4

<b>Type</b>
0 : Standard
5 : For progressive start-up valve



► **Assembling kit for manifold regulators**

170 M6

<b>Size</b>
170 : Size 1



► **Flange G3/4"**

1738 1E

<b>Size</b>
1738 : Size 3

<b>Type</b>
1E : Inlet flange
2E : Output flange

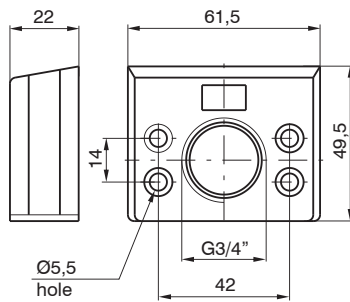

Size 3

2 AIR TREATMENT