

**VALVOLE A SFERA THOR SPLIT BODY
BALL VALVES THOR SPLIT BODY
THOR SPLIT BODY KUGELHÄHNE
VÁLVULAS ESFÉRICAS THOR SPLIT BODY**

T1 **PN16-40
ANSI150-300**



Valvole a sfera/balls valves/kugelhähne			CATEGORIA DI RISCHIO/RISK CATEGORY/KATEGORIE			
SERIE/SERIES/SERIE	ANSI	PN	I°		II°	III°
T1	150	16-40	≤ DN 25	DN 32 ÷ DN 50	DN 32, 40, 50, 80	
		16		DN 65 ÷ DN 200		
	25-40	DN 32 ÷ DN 50		DN 65 ÷ DN 150	DN 250	
	300	DN 65 ÷ DN 100		DN 32 ÷ DN 100	DN 125 ÷ DN 250	

OMAL S.p.A.
VIA PONTE NUOVO 11 - 25050 RODENGO SAIANO (BS) I - TEL. +39 030 8900145 r.a. - FAX +39 030 8900423
Web Site: www.omal.it e-mail: info@omal.it
This document can be downloaded from our web site www.omal.com

N°	Description
1	Corpo Body Gehäuse Cuerpo
2	Terminale Connector Anschluss Conector
3	Sfera Ball Kugel Esfera
4	Stelo Stem Spindel Vástago
5*	Seggio Seat Sitz Asiento
6*	Guarnizione corpo-terminale Body-connector gasket Dichtung Gehäuse-Anschluss Junta cuerpo-conector
7*	Tenuta inferiore stelo Stem lower sealing untere Spindeldichtung Retén inferior vástago
8*	Pacco a V Chevron rings Chevron-Dichtungen Conjunto a V
9*	O-ring stelo Stem o-ring Spindel O-Ring O-ring vástago
10	Anello premiguarnizione Packing gland ring Stoffbuchse Ring Anillo compresión guarniciones
11	Piastra blocca dado Stop nut plate Mutterbefestigungsscheibe Placa bloqueo tuerca
12	Dado stelo Stem nut Spindelmutter Tuerca vástago
13	Molle a tazza Springs washer Tellerfedern Muelle cóncavo
14	Dispositivo antistatico Antistatic device Antistatische Vorrichtung Dispositivo antiestático
15	Tiranti Stud bolt Zugstange Espárragos
16	Dadi Nut Muttern Tuercas
17	Controdado Lock nut Gegenmutter Contratuerca
18	Vite di fermo Holder screw Befestigungsschraube Tornillo de tope
19	Fermo di posizione Holder screw Feststellvorrichtung Tope de posición
20	Leva Lever Handhebel Manija
21	Riduttore Gear box Getriebe Reductor
22	Volantino Handweel Handhebel Volante

* Componenti del kit di guarnizioni Components of seals kit
Ersatz (in Ersatzkit inbegriffen) Componentes de kit de sellos

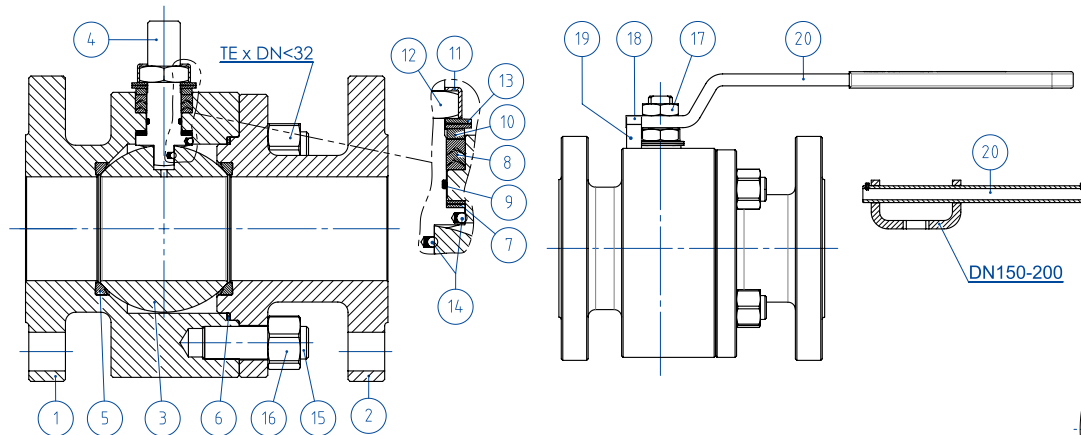

**Coppia di chiusura dado (12)
Nut assembling torque (12)
Mutter-Drehmoment (12)
Torque de cierre tuerca (12)**

DN	Nm
15-20	5
25-32	8
40-50	15
65-80	30
100-125	50
150	90
200	120



Diagramma pressione/temperatura per valvole con corpo in acciaio carbonio
Temperature/pressure diagram for carbon steel valve



Diagramma pressione/temperatura per valvole con corpo in acciaio inox
Temperature/pressure diagram for stainless steel valve

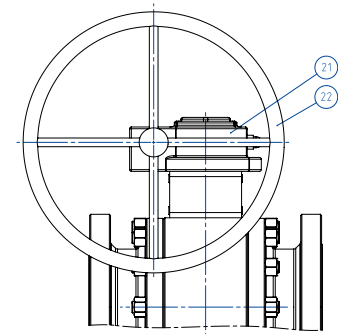
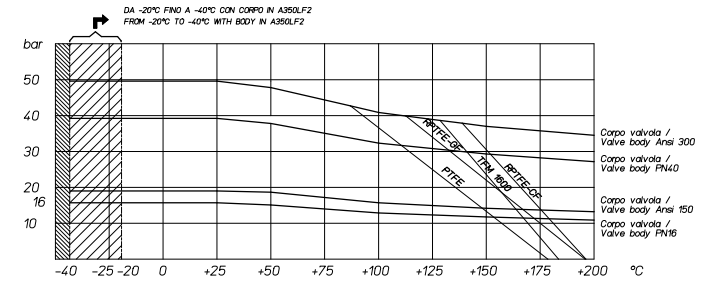