



Know-how makes the difference



ELECTRICAL ACTUATOR

TYPE 5630-006

Installation, Operation, Maintenance Manual



With Dansk Ventil Center A/S as your business partner, you are always guaranteed a wide and well sorted product range and a unique technical know-how

Product development is a key factor for DVC, ensuring you the best products at any time



INDEX

1 INTRODUCTION	1
2 PRODUCT IDENTIFICATION.....	1-2
3 GENERAL INFORMATION AND FEATURES.....	2-4
4 INSTALLATION	4-11
5 OPERATION.....	11-12
6 MAINTENANCE.....	12-13
7 TROUBLE SHOOTING	13
8 DIMENSIONS.....	14

1. INTRODUCTION

1.1 Purpose

The purpose of this manual is to introduce and explain the installation, operation and maintenance of 5630-006 electric actuators.

1.2 Safety notices

Safety notices in this manual outline precautions the user must take to reduce the risk of personal injury and damage to the equipment. The user(s) must read these instructions before the installation, operation or maintenance of 5630-006 electric actuators.

 **DANGER:** Refers to personal safety. Alerts the user to danger or harm. The hazard or unsafe practice will result in severe injury or death.

 **WARNING :** Refers to personal safety. Alerts the user to potential danger. Failure to follow warning notices could result in personal injury or death.

 **CAUTION** Directs the user's attention to general precautions that, if not followed, could result in personal injury and/or equipment damage.

2. PRODUCT IDENTIFICATION

2.1 Product identification

The actuator name plate is located on the opposite side of the conduit entry. The name plate contains the following:

2.1.1 Marking

A) General

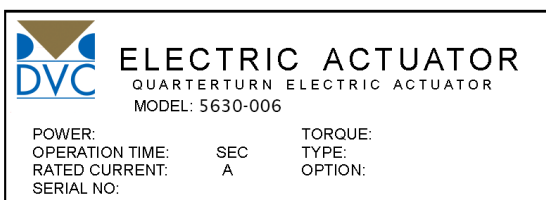

DVC logo (trade mark)

Model

Electrical Power Supply

Torque

Operating time (Seconds)

Type

Rated current

Option

Serial No.

NOTE: NAME OF MANUFACTURER AND COUNTRY SHALL NOT BE PRINTED BASED ON OEM.

2.2 Initial inspection

Upon receipt of the actuator, the user should inspect the condition of the product and ensure that product specification stated in the name plate matches with the order sheet.

- Remove the packing wrap or wooden box carefully. Inspect the product for any visible damage that may have occurred during shipment.
- Check the product specification with product ordered. If a wrong product has been shipped, immediately report to your supplier.

2.3 Storage

Actuators must be stored in a clean, cool and dry area. The unit should be stored with the cover installed and the conduit openings sealed. Storage must be off the floor, covered with a dust protector. When actuators are stored outdoor, they must be stored off the ground, high enough to prevent from being immersed in water or buried in snow.

3. GENERAL INFORMATION AND FEATURES

3.1 General information

5630-006 electric actuators are designed to provide reliable and efficient operation of 90 degree quarter turn valves, such as damper valves, etc.

3.1.1 Performance standard

TYPE	MAX OUTPUT TORQUE Nm	OPERATING TIME SEC. 60/50 Hz 90°	DUTY CYCLE IEC34-1 S4(%)	MOUNTING SIZE ISO 5210	POWER 1 PHASE AC or DC	RATED CURRENT (A) 60/50 Hz 1 PHASE			WEIGHT KG
						110V	230V	24V	
5630-006	60	12/14	50	F03, F05, F07	110V, 230V AC or 24V DC	0.4A / 0.39A	0.2A / 0.19 A	0.2A	3

3.1.2 Technical data

ENCLOSURE RATED	Weatherproof IP67, NEMA 4 & 6
ENCLOSURE	High grade aluminum alloy, corrosion coated
POWER SUPPLY	110 / 230V AC 1 Ph 60/50Hz 24 V DC
DUTY TYPE	S4 50% / S2 30min (IEC 60034)
MOTOR	AC reversible motor
LIMIT SWITCHES	2 x open/close SPDT, 250V AC 5A rating
AUXILIARY LIMIT SWITCHES	2 x open/close SPDT, 250V AC 5A rating
TORQUE SWITCHES	N/A
INDICATOR	Continuous position indicator
MANUAL OVERRIDE	Manual handle
SPACE HEATER	1W
CONDUIT ENTRIES	2 x PG13.5
LUBRICATION	Moly EP Grease
AMBIENT TEMPERATURE	-20°C ~ + 80°C
EXTERNAL COATING	Powder coated polyester

3.1.3 Optional technical data

WTA	Watertight Enclosure (IP68 10m / 24hr)
PIU	Potentiometer Unit (0~1KΩ)
PCU	Proportional Control Unit (input, output 0~10V DC, 4~20mA)
CPT	Current Position Transmitter (output 4~20mA)

3.1.4 Duty cycle

Duty cycle rated IEC60034 – S4 50% / S2 30 min

Exceeding the actuator's rated duty cycle may cause thermal overload.

NOTE: ¹TYPE OF DUTY ACCORDING TO VDE 0530 / IEC 60034-1

SHORT – TIME DUTY S2	INTERMITTENT DUTY S4
The operation time at a constant load is short, so that thermal equilibrium is not reached. The pause is long enough for the machine to cool down to ambient temperature. The duration of the short –time operation is limited to 15min (10min, 30min)	The duty is a sequence of identical cycles which consist of starting time, operation time with constant load and rest period. The rest period allows the machine to cool down so that thermal equilibrium is not reached. The relative on-time at S4-25% or S4-50% is limited to 25% and 50% respectively.

3.1.5 Heater

Condensation in the actuator is possible due to wide fluctuation of the ambient temperature. The heater integrated in the control unit prevents this in general.

3.1.6 Manual override

5630-006 actuators are provided with a manual system. The standard 5630-006 actuators come with a manual override hand wheel. This hand wheel is located at the bottom of the unit and can be easily operated with a Hex wrench. Turn the hand wheel until the valve reaches the required position (turn clockwise to fully open and counter-clockwise to fully close).

Caution! here must be no voltage while turning the actuator.

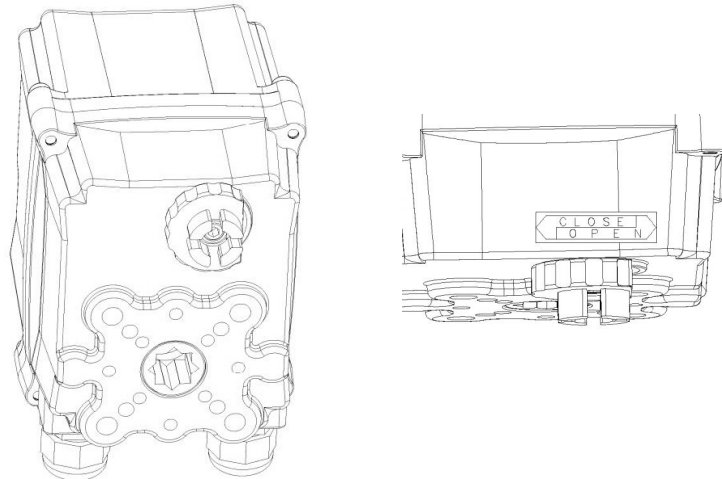

3.1.7 Lubrication

5630-006 electric actuator is a totally enclosed unit with permanent lubricated gear train (Moly EP Grease). Once installed, further lubrication should not be required. However, periodic preventative maintenance will extend the operating life of the actuator.

3.2 External parts for standard models

POS.	EXTERNAL PARTS
1	Top Cover
2	Body
3	Cable Entry (Pg 13.5) X 2
4	Drive Shaft (Star 14mm)
5	Mounting Base (F03, F05, F07)
6	Hand Wheel
7	Name Plate
8	Cover Bolt
9	Indicator

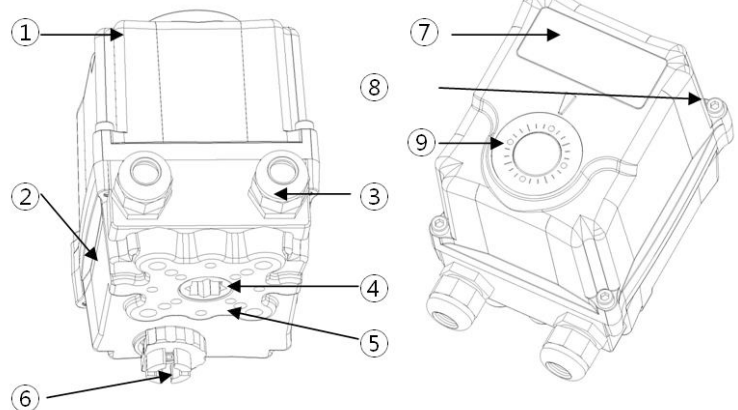

3.3 Internal parts for standard models

POS.	INTERNAL PARTS
1	Motor
2	Indicator
3	Open Limit Switch
4	Close Limit Switch
5	Additional Open Limit Switch
6	Additional Close Limit Switch
7	Potentiometer Unit
8	Terminal
9	Heater
10	Capacitor

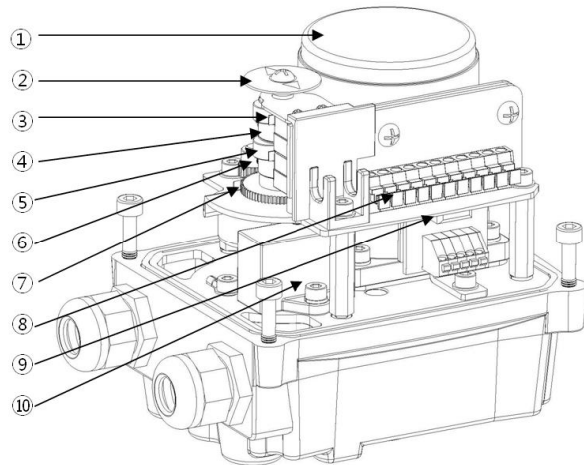

4. INSTALLATION

4.1 Pre-installation for using in general service

Verify the actuator's nameplate to ensure correct model number, torque output, operating speed, voltage and enclosure type before installation or use. It is important to verify that the torque output of the actuator is appropriate for the torque requirements of the valve, and that the duty cycle of the actuator is appropriate for the intended application.



WARNING:

Read this installation, operation and maintenance manual carefully and completely before attempting to install, operate, or troubleshoot the 5630-006 actuator.

4.2 Actuator mounting

NOTE: Prior to mounting, the actuator must be checked for any damage. Damaged parts must be replaced by original spare parts.

Mounting is most easily done with the valve shaft pointing vertically upward. But mounting is also possible in any other position, the actuator may be mounted in any position. The 5630-006 series actuators are supplied with Union joints & nuts, the Union joints are removable for the ease of assembly.



CAUTION:

- Do not attempt to work on your actuator without first shutting off the incoming power
- Do not attach ropes or hooks to the hand wheel for the purpose of lifting by hoist

4.2.1 Actuator mounting base details

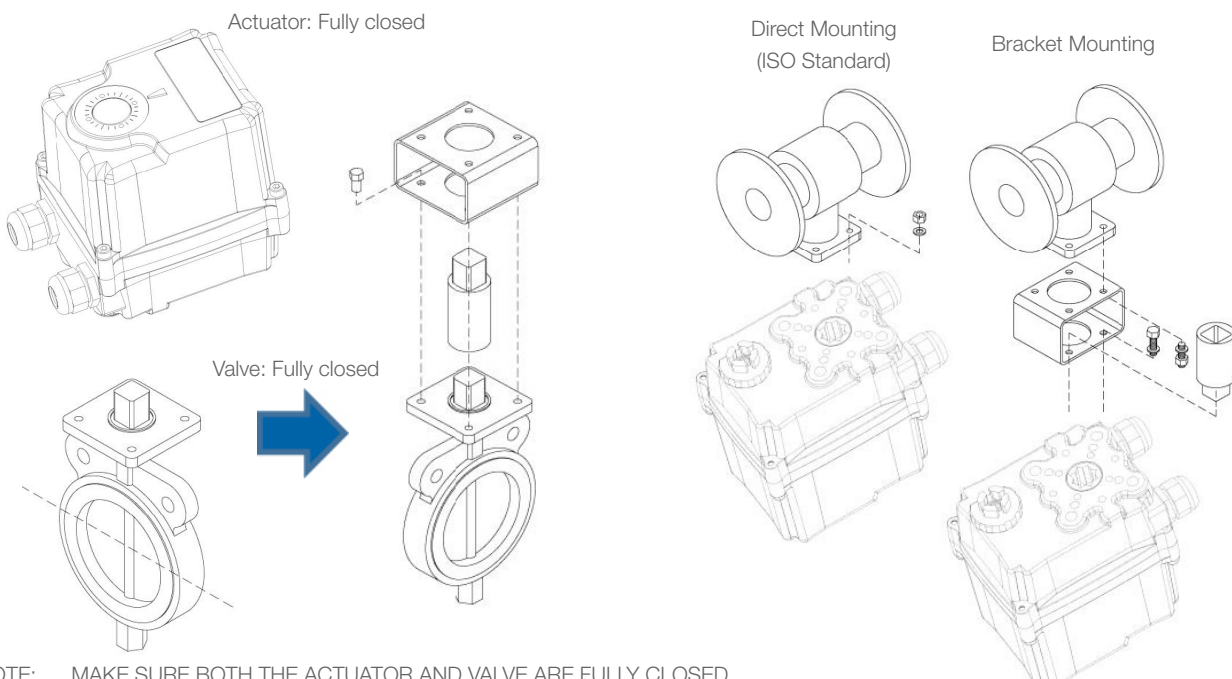

NOTE: MAKE SURE BOTH THE ACTUATOR AND VALVE ARE FULLY CLOSED.

4.2.1 Actuator mounting base details

Actuator Mounting Base: F03/F05 and F07

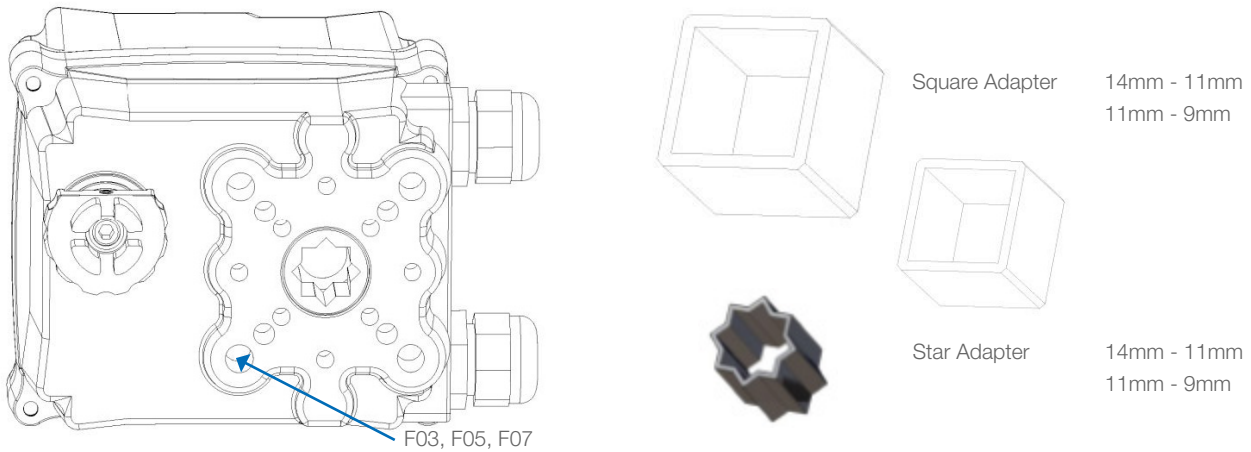

⚠ DANGER:
HAZARDOUS VOLTAGE. Make sure all incoming power is disconnected before performing the mounting.

4.3 Limit switch setting

- Manually rotate the hand wheel of the actuator to fully closed position
- Using a hex wrench, loosen the set screw in the CLOSE limit switch cam
- Rotate the CLOSE cam towards limit switch lever until the switch 'clicks' (see Figure 1 below)
- Tighten the set screw with the hex wrench
- Manually rotate the hand wheel of the actuator to opened position
- Using the hex wrench, loosen the set screw in the OPEN limit switch cam
- Rotate the OPEN cam towards limit switch lever until the switch 'clicks' (see Figure 2 below)
- Tighten the set screw with the hex wrench

⚠ DANGER:
HAZARDOUS VOLTAGE. Make sure all incoming power is disconnected before setting the limit switch.

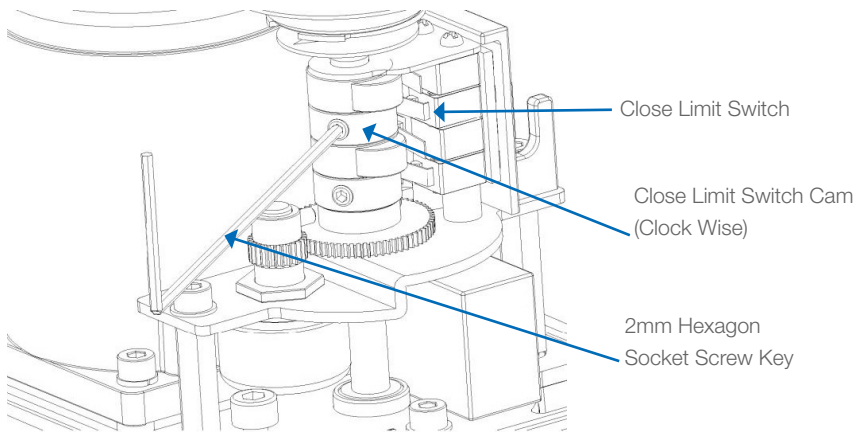

FIGURE 1: CLOSE CAM SETTING

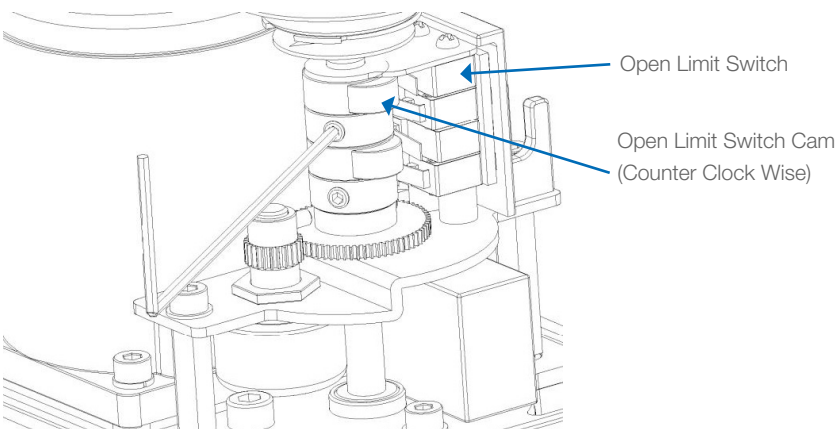

FIGURE 2: OPEN CAM SETTING

4.4 Setting potentiometer (replacement and setting)

The potentiometer has been calibrated at factory. However, if re-calibration is required, proceed as follows:

- Manually rotate the hand wheel of the actuator to fully closed position.
- While measuring the resistance between P1 (orange) and P2 (grey), gently rotate the Potentiometer Gear until it reaches between 80 - 120 Ω (100 Ω preferred).
- Engage the Potentiometer Gear into the Point Shaft Gear and use an Hex wrench to tighten the screw.

⚠ DANGER:
HAZARDOUS VOLTAGE. Make sure all incoming power is disconnected before setting the potentiometer

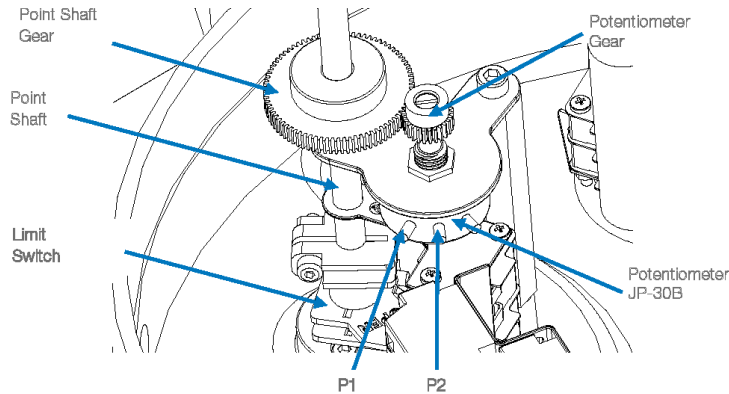

4.5 Current position transmitter – CPT (optional)

The potentiometer is used for the actuator signal feedback. It reads a resistance value corresponds to the current position of the actuator and transfers to CPT card. The CPT indicates the current position of the actuator throughout the stroke by a 4 – 20mA output signal.

4.5.1 Standard features

MODEL	CPT
POWER	110 / 230V AC, 50/60Hz 2VA Max
OUTPUT SIGNAL	4~20mA
OUTPUT IMPEDANCE	750 Ω Max
RESOLUTION	Min 1/1000
POSITION CONVERSION ACCURACY	$\pm 0.5 \sim \pm 1.5\%$
AMBIENT TEMPERATURE	-20°C To +70°C
AMBIENT HUMIDITY	90% RH Max (Non-Condensing)
DIELECTRIC STRENGTH	1500V AC 1 Min (Input To Output To Power Ground)
INSULATION RESISTANCE	ABOVE 500V DC 30M Ω
VIBRATION	10G, 0~34Hz

⚠ DANGER:
HAZARDOUS VOLTAGE. Make sure all incoming power is disconnected before setting the actuator

4.5.2 Calibration of Zero and Span - CPT

The settings of Zero and Span have been calibrated at the factory. However, if re-calibration is required, proceed as follows:

- Use the hand wheel to drive the actuator to a half open position.
- Apply power (or use the manual override) to drive the actuator to its fully closed position (clockwise rotation).
- When the actuator is in the fully closed position, adjust the ZERO dial on the CPT board until a reading of 4mA is achieved.
- Apply power (or use the manual override) to drive the actuator to its fully open position (counter-clockwise rotation).
- When the actuator is in the fully open position, adjust the SPAN dial on the CPT board until a reading of 20mA is achieved.

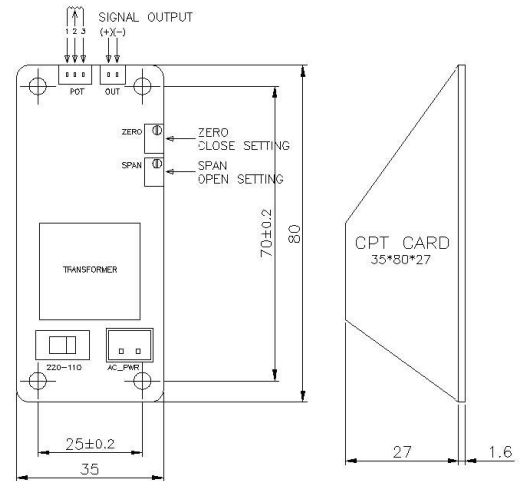

4.6 Proportional Control Unit (PCU-A)

PCU-Rev-4 High Performance Controller, using 10 bit A/D converter and 8bit microprocessor technology.

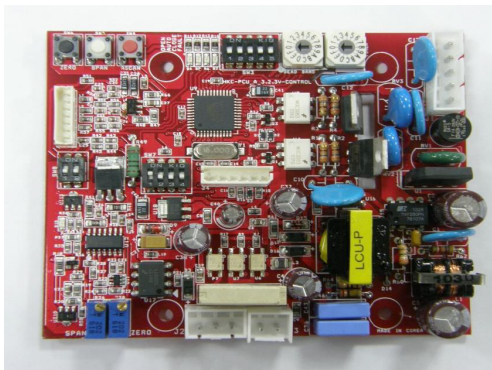

The factory settings of the PCU card are normally set according to the customer requirements at the time of order. However, we strongly recommend that input power, signal input selection and dip switches are to be verified prior to the actuator start up.

PCU-REV-4 FEATURES	
MODEL	PCU-Rev-4
POWER	85 ~ 260 VAC Free Voltage \pm 10%, 50/60Hz 4 VA Max
INPUT SIGNAL	4~20mA, 1~5V DC, 2~10V DC, 0~5V DC, 0~10V DC
INPUT IMPEDANCE	250 Ω
OUTPUT SIGNAL	4~20mA, 1~5V DC, 2~10V DC, 0~5V DC, 0~10V DC
OUTPUT IMPEDANCE	750 Ω Max
OUTPUT CONTACT	1 (Fault monitor)
DELAY TIME ADJUSTMENT	0.05~7.5 seconds
DEADBAND ADJUSTMENT	0.12mA DC Max
RESOLUTION ADJUSTMENT	0.0625~1mA (0.0625mA+step no. x 0.0625mA, 15 steps total)
AMBIENT TEMPERATURE	-10°C to +70°C
AMBIENT HUMIDITY	90% RH Max (non-condensation)
DIELECTRIC STRENGTH	1500V AC 1 Minute (input to output, power to ground)
INSULATION RESISTANCE	Minimum 500V DC 30M Ω

⚠ CAUTION: HAZARDOUS VOLTAGE. TURN OFF ALL POWER BEFORE SETTING YOUR ACTUATOR.

4.7 Proportional Control Unit (PCU-D)

PCU-Rev-D1 High Performance Controller, using 10 bit A/D converter and 8bit microprocessor technology.

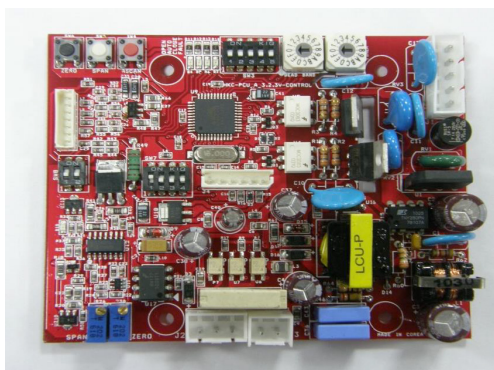

The factory settings of the PCU card are normally set according to the customer requirements at the time of order. However, we strongly recommend that input power, signal input selection and dip switches are to be verified prior to the actuator start up.

PCU-REV-4 FEATURES	
MODEL	PCU-Rev-D1
POWER	24V DC Voltage \pm 15% (36V DC Max)
INPUT SIGNAL	4~20mA, 1~5V DC, 2~10V DC, 0~5V DC, 0~10V DC
INPUT IMPEDANCE	250 Ω
OUTPUT SIGNAL	4~20mA, 1~5V DC, 2~10V DC, 0~5V DC, 0~10V DC
OUTPUT IMPEDANCE	750 Ω Max
OUTPUT CONTACT	1 (Fault monitor)
DELAY TIME ADJUSTMENT	0.05~7.5 seconds
DEADBAND ADJUSTMENT	0.12mA DC Max
RESOLUTION ADJUSTMENT	0.0625~1mA (0.0625mA + step no. x 0.0625mA, 15 steps total)
AMBIENT TEMPERATURE	-25°C to +80°C
AMBIENT HUMIDITY	90% RH Max (non-condensation)
DIELECTRIC STRENGTH	1500V AC 1 Minute (input to output, power to ground)
INSULATION RESISTANCE	Minimum 500V DC 30M Ω

⚠ CAUTION: HAZARDOUS VOLTAGE. TURN OFF ALL POWER BEFORE SETTING YOUR ACTUATOR.

4.7.1 LED Signal indication

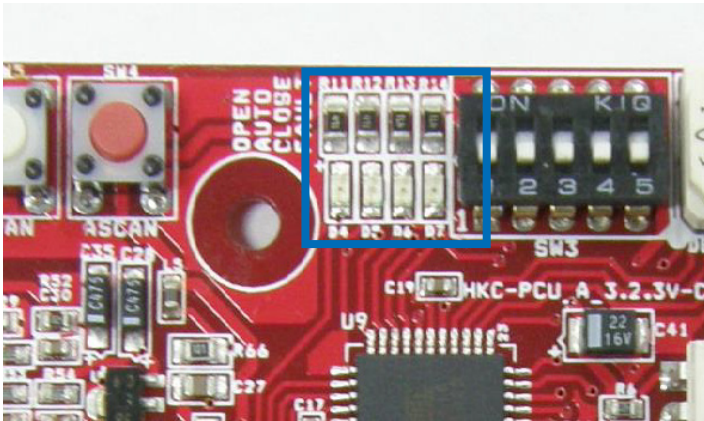

LED	STATE	INDICATION
Blue	On	Power On (Auto)
	Flickering	Auto Calibrating
Green	On	Fully Closed
	Flickering	Closing
Red	On	Fully Open
	Flickering	Opening
Yellow	On	Manual Mode: Fault Indication, Either: - No Input Signal - Wrong Input Wiring - Wrong PCU Setting
	Flickering	

4.7.2 Setting PCU functions

A) Selecting input signal

- User can select different types of input signal by adjusting the DIP switches as follows:

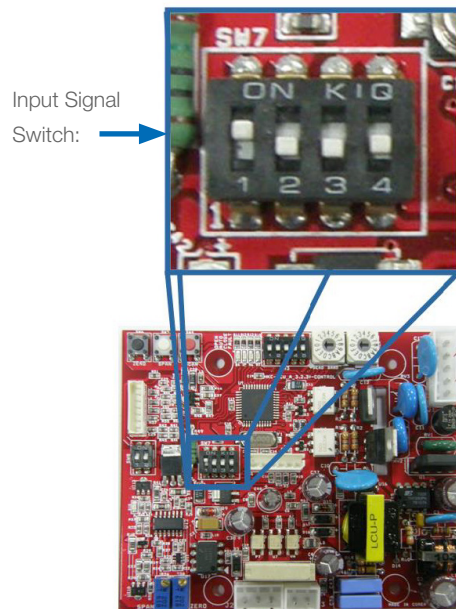
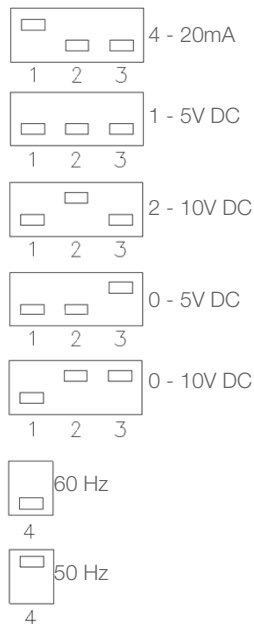

NOTE: IF NOT SPECIFIED, THE FACTORY SETTING OF THE INPUT SIGNAL IS 4 - 20mA.

B) Selecting output signal

- User can select different types of output signal by adjusting the DIP switch as follows:

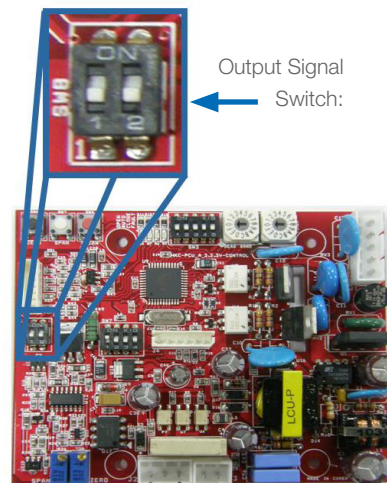
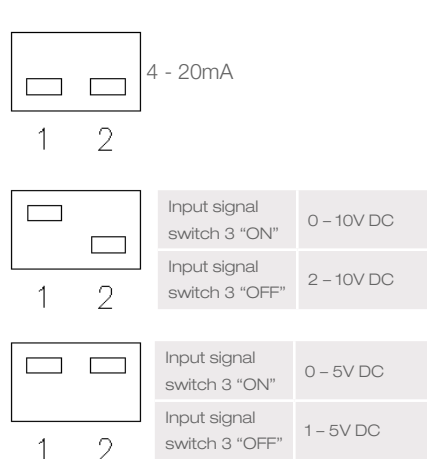

NOTE: IF NOT SPECIFIED, THE FACTORY SETTING OF THE OUTPUT SIGNAL IS 4 - 20mA.

C) Fail position setting

- User can select the fail position of the actuator in case of control signal failure by adjusting the DIP switches as follows:

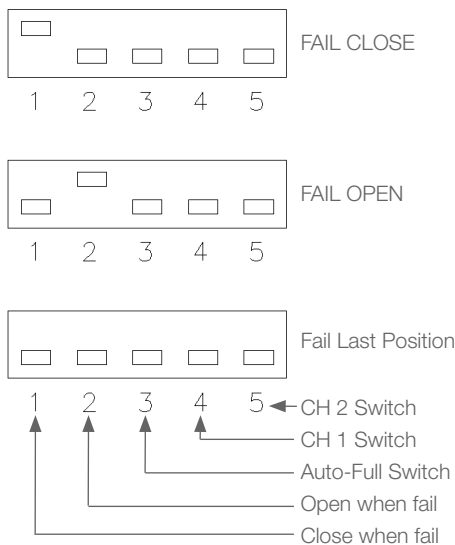

Fail Position Setting Switch

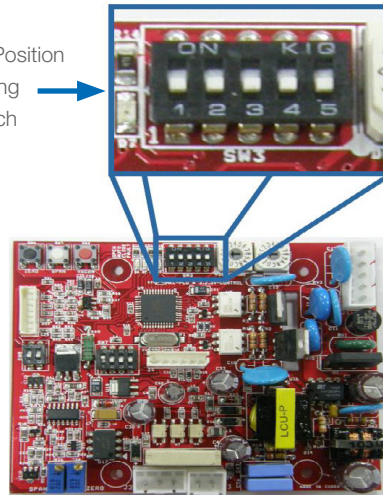

NOTE: If not specified, the factory setting of the output signal is 4 - 20mA.

D) Special signal setting for fully open and fully closed

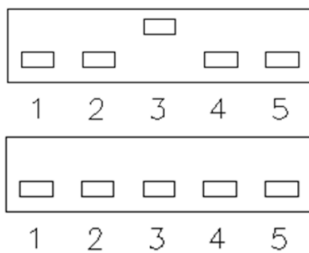

Auto-Full Switch (Switch 3) On (up)	Signal: 4.3mA Signal: 19.7mA	Fully Closed Fully open
--	---------------------------------	----------------------------

Auto-Full Switch (Switch 3) Off (down)	Signal: 4.0mA Signal: 20.0mA	Fully Closed Fully open
---	---------------------------------	----------------------------

E) Auto setting

- This function is used for automatic setting of the PCU card to the predefined limits.
 - While the actuator is corrected mounted on the valve, check input power, input and output signal connections.
- Press ASCAN button once, regardless of the position of the actuator, then the actuator will perform the Auto Setting motion:

- 1) The blue LED flicker
- 2) Opening (the red LED flickering) for 5 seconds
- 3) Pause for 2 seconds
- 4) Fully closing (the green LED flickering)
- 5) Pause (the green LED on) for 3 seconds
- 6) Fully opening (the red LED flickering)
- 7) Pause (the red LED on) for 3 seconds
- 8) Moving back to the previous position

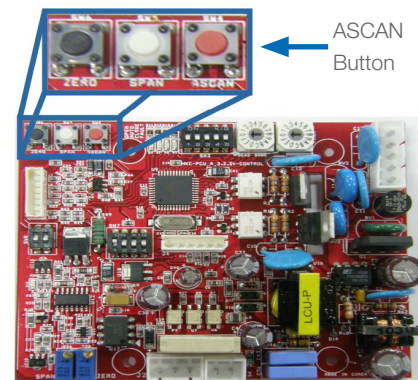

NOTE: Since the unit is already set at the factory, no further setting is required unless the user has adjusted the mounting state of Limit Switch or the Potentiometer.

F) Manual operation

- This function allows the user to manually operate the actuator.
- To access this function, press the ZERO (black) and SPAN (white) buttons simultaneously for 2 seconds and the yellow LED will be lit to indicate that the actuator is in Manual Operation mode
- Pressing the ZERO button will move the actuator to close and pressing the SPAN button will move the actuator to open
- If no operation occurs within 5 seconds, the PCU automatically terminates the Manual Operation mode or alternatively press the ZERO and SPAN buttons simultaneously for 2 seconds. In either case, the yellow LED will be lit off to indicate the termination of the Manual Operation Mode.

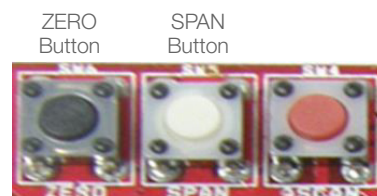

NOTE: During the manual operation mode, the input signal is ignored.

G) Customizing set-points (CH 1 Switch)

- This function is used when the user wants to set different set-points for fully open and fully closed positions.
- For example, if the user wants to assign 5mA as the set-point for fully closed position, first of all switch-on (move up) the CH1 switch (switch 4). Supply a 5mA signal and push the ZERO button once. Hereafter, the actuator will acknowledge 5mA signal as the set-point for fully closed position and transmits 4mA feedback signal. Similarly, for setting the set-point for the fully open position, supply the desired signal (for example, 19mA) and push the SPAN button once. Switch-off (move down) the CH1 switch to complete the setting.

SET-POINTS	ADJUSTABLE RANGE
Fully Closed	3-8 mA DC
Fully Open	16-21 mA DC

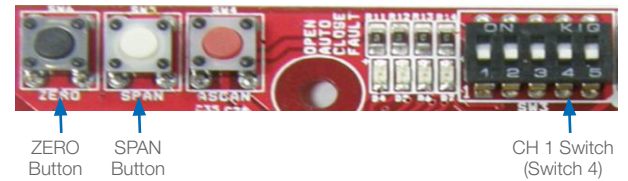

NOTE: During the Manual Operation mode, the input signal is ignored.

H) Reversal acting (CH 2 Switch)

- This function allows the user to reverse the input and output signals for the operation of the actuator.
- For standard operation (CH 2 switch down), the input signal of 4mA operates the actuator to fully close and the actuator transmits the output signal of 4mA. However, when CH 2 switch is on (move up) the input signal of 4mA operates the actuator to fully open and still transmits 4mA output signal.
- Manually move the actuator to half-open position and push ASCAN button once to execute the Auto Setting (see 4.7.2 E). Supply signal and check the operation.

CH 2 Switch	4mA DC Fully open
(Switch 5) On (up)	20mA DC Fully closed
CH 2 Switch	4mA DC Fully open
(Switch 5) Off (down)	20mA DC Fully closed

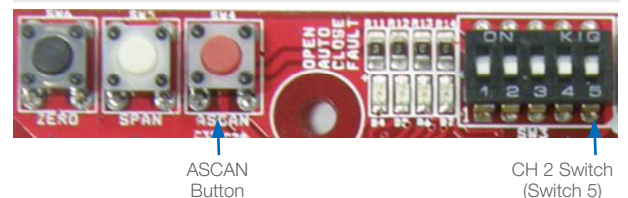

I) Delay time

- The actuator starts to move if and only if the change in the input signal value is greater than the resolution set value (see 4.7.2 J) and when the signal value is maintained for the duration of the delay time.
- This prevents malfunction of the actuator caused by unwanted signals in the input signal such as noise and interferences.
- Turning the Delay Time Dial in clockwise direction will increase the delay time (Range 0.05 to 7.5 seconds).

DIAL	0	1	2	3	4	5	6	7
SEC	0.05	0.2	0.4	0.6	0.8	2.5	3.0	3.5
DIAL	8	9	A	B	C	D	E	F
SEC	4.0	4.5	5.0	5.5	6.0	6.5	7.0	7.5

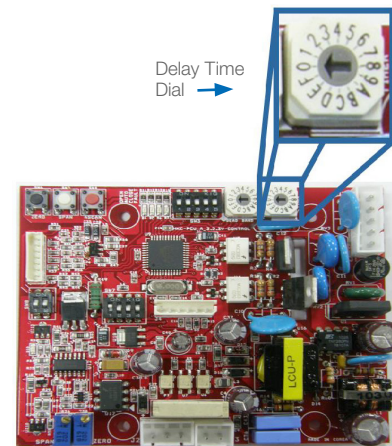

J) Deadband

- The deadband adjusts the limits of the valve's deviation between an actual position and a target position. The deadband is set to 0.12mA DC Max.
- Resolution indicates the extent of the reaction on the input signal.
- Low resolution setting may cause the actuator to seek or to unnecessarily respond to a fluctuating input signal. If so, the resolution must be increased.
- Turning the deadband dial in clockwise direction will increase the resolution (Range 0.0625mA to 1mA).

DIAL	0	1	2	3	4	5	6	7
mA	0.0625	0.125	0.1875	0.25	0.3125	0.375	0.4375	0.5
DIAL	8	9	A	B	C	D	E	F
mA	0.5625	0.625	0.6875	0.75	0.8125	0.875	0.9375	1

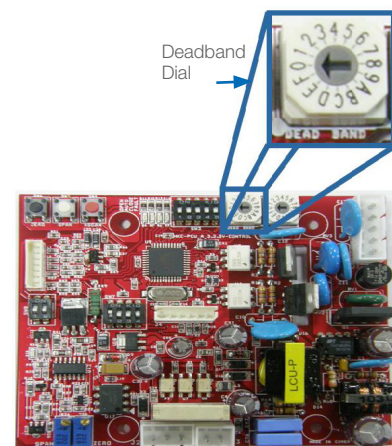

4.8 AC/DC Multi-Board

A) Terminal block

- 2 CLOSE LAMP
- 3 NONE
- 4 OPEN LAMP
- 5 NONE
- 6 LAMP COM
- 7 Power 24V AC/DC (DC + input terminal)
- 8 CLOSE signal
- 9 OPEN signal
- 10 NONE
- 11 NONE
- 12 Power 24V AC/DC (DC - input terminal)

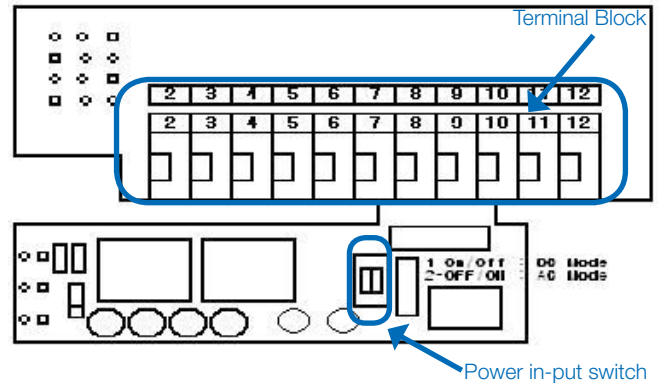

B) Power in-put switch

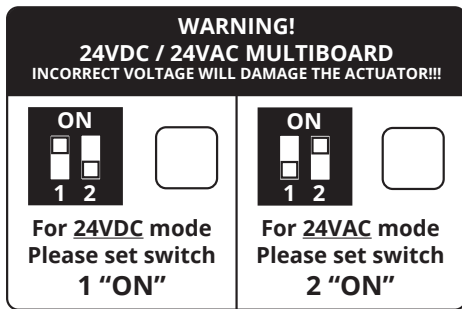

* NOTICE: Don't turn on both switch #1 and #2 at the same time, it can result in, damaged board.

5. OPERATION

5.1 Electrical connections and preliminary test

- For testing purposes, loosen the bolts on the actuator cover and remove the cover.
- Make sure that the power supply voltage is in accordance with the data on the nameplate of the actuator.
- Connect wires according to the enclosed wiring diagram (see Chapter 2)
- Manually move the valve to half-open position. Then electrically operate the actuator to fully open position and check if the motor rotates in correct direction; standards units are counter-clockwise to open.
- Test the actuator and check whether the limit switches work correctly
- After the testing, check that all cable glands are correctly tightened. Applicable cable glands should be selected to meet the application's condition. It is recommended to use the grade of IP67 cable gland or higher in potentially explosive sites.
- Put back the cover and tighten the bolts.



DANGER: HAZARDOUS VOLTAGE. No electrical power should be connected until all wiring and limit switch adjustments have been completed. Once the power is supplied to the unit, caution when the cover is not installed.

5.2 Wiring Diagrams for standard models

5.2.1 5630-006 On/Off type - 230 VAC

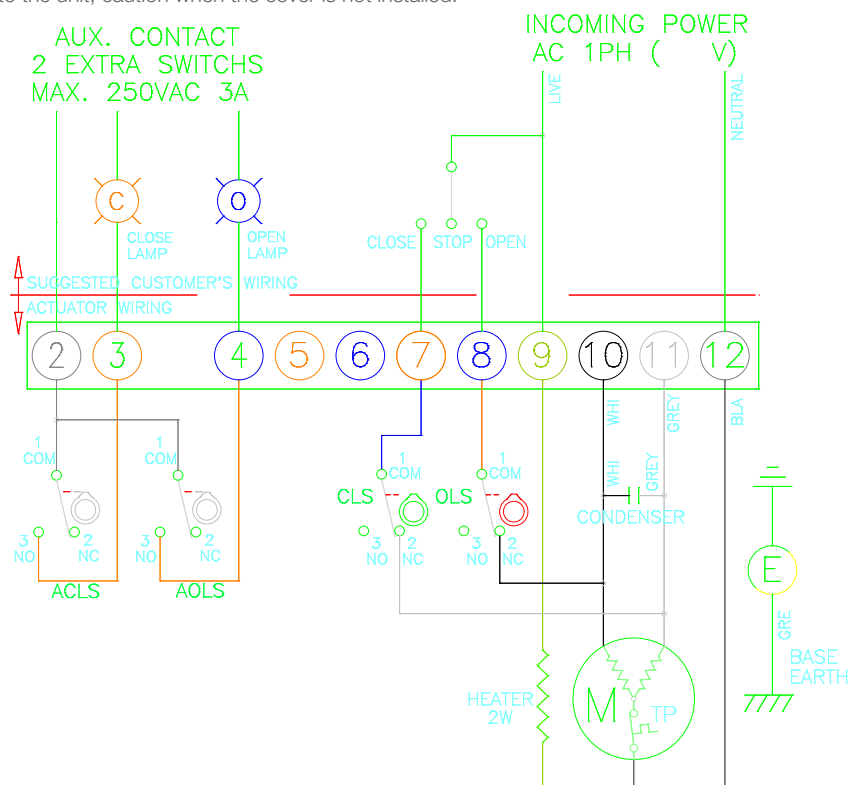

5.2.2 5630-006 PCU type
24 VAC

24 VDC

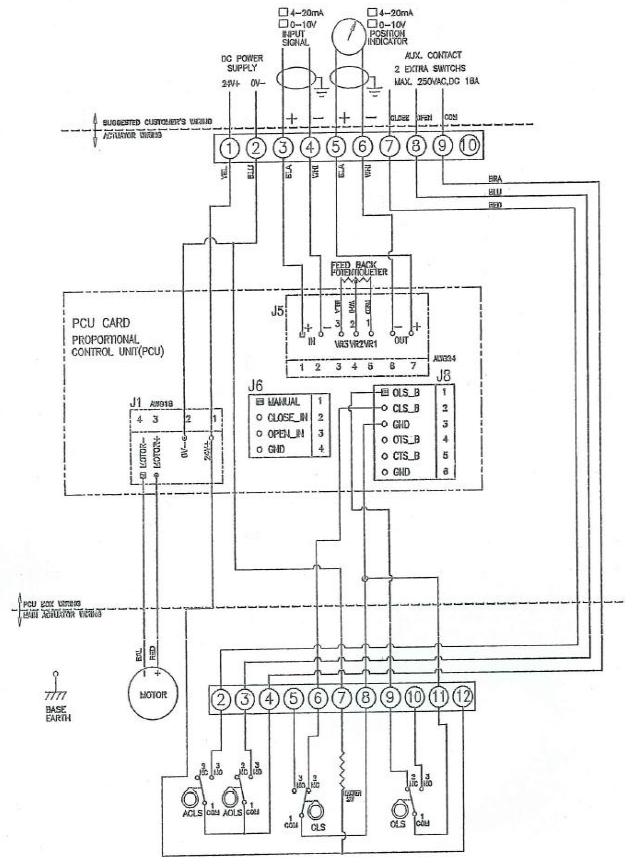
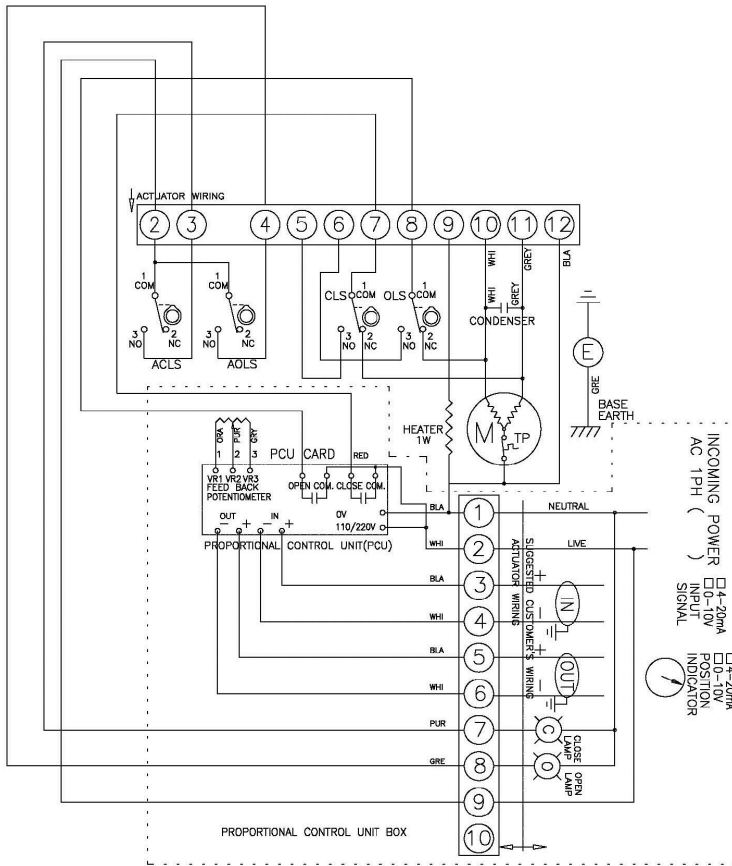

5.2.3 5630-006 On/Off type

24 VAC

24 VDC

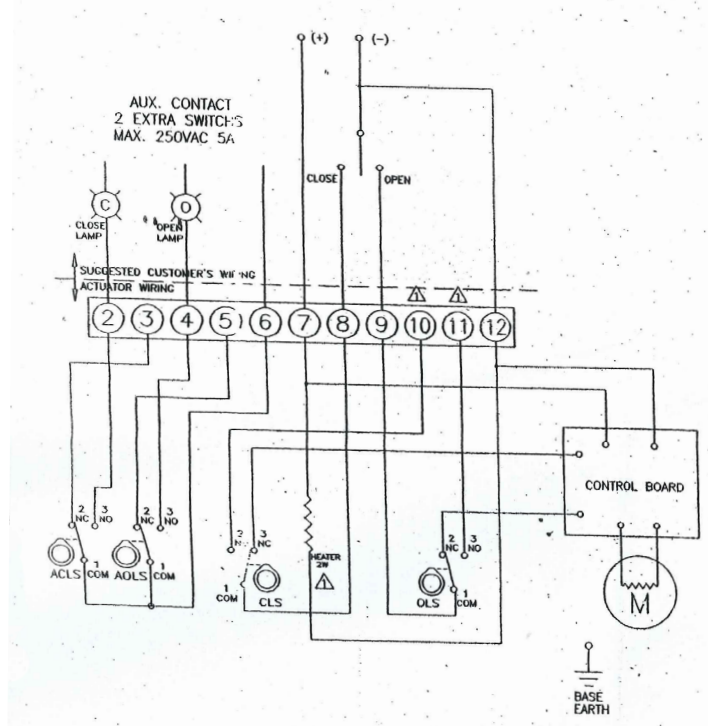
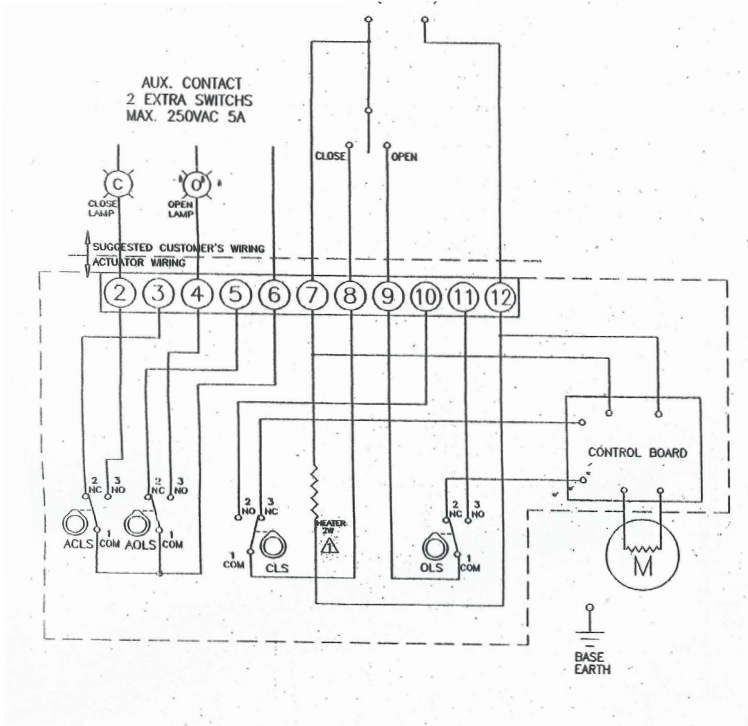

DANGER:

HAZARDOUS VOLTAGE. No electrical power should be connected until all wiring and limit switch adjustments have been completed. Once the power is supplied to the unit, caution when the cover is not installed.

6. MAINTENANCE

6.1 Maintenance



CAUTION:

- Turn off all power before attempting to perform maintenance on the actuator.
- **POTENTIALLY HIGH PRESSURE ITEM.** Before removing or disassembling your actuator, ensure that the valve or other actuated device is isolated and not under pressure.

Under the normal conditions, maintenance should be carried out at six month intervals. But when the conditions are more harsh, more frequent inspections may be advisable.

- Ensure that the actuator is properly aligned with the valve or other actuated device.
- Ensure that all wirings are insulated, connected properly.
- Ensure that all screws are present and tightened.
- Ensure cleanness of internal electrical devices.
- Ensure that conduit connections are properly installed and are dry.
- Check the internal devices for any condensation.
- Check the power to the internal heater.
- Check the enclosure of O-ring seals and verify that the O-rings are not pinched between flange.
- Verify the declutch mechanism.
- Visually inspect the open/close cycle.
- Inspect the identification labels for wear and replace it if necessary.



WARNING: Treat cover with care. Gap surfaces must not be damaged or dirtied in any way. Do not jam the cover during fitting.

6.2 Tools

- Metric Allen Key (Hex Wrench) × 1
- Screw Driver × 1
- Metric Spanner × 1
- Wrench 200mm × 1
- Wrench 300mm × 1
- Wire Stripper Long Nose × 1
- Multi-meter (AC, Dc, Resistance) × 1
- PCU Board Option: DC Signal Generator (4 – 20mA DC) × 1
- PCU & CTU Board Option: 1mA Ammeter (0 – 25mA)

7. TROUBLE SHOOTING

The following instructions are listed in the order of the most common difficulties encountered during the installation and start-up.

SYMPTOM	PROBABLE CAUSE	CORRECTIVE ACTION
Motor will not run	Open in control circuit Insulation resistance breakdown in motor	Refer to appropriate wiring diagram and check for continuity
No power available to actuator	Tripped circuit breaker	Reset circuit breaker
Manual Override hand wheel hard to turn	Valve stem improperly lubricated Actuator lubrication has broken down Valve packing gland too tight Jammed valve	Lubricate with grease Clean out old grease and replace with recommended lubricant Loosen packing gland nuts as necessary Refer to valve maintenance
Valve only opens or closes partially with motor	Limit switch improperly set	Check setting and reset if necessary
Manual Override hand wheel will not operate valve	Stripped gearing Broken hand wheel shaft Broken valve stem	Replace as necessary Replace as necessary Repair or replace as necessary
Motor runs but will not operate valve	Stripped gearing	Replace as necessary

The actuator does not respond

- Visually inspect the actuator to check no shipping or handling damage has occurred
- Verify the line voltage supplied to the actuator; check that the line voltage matches with the rating on the actuator's nameplate
- Check the internal wiring against the supplied wiring diagram of the actuator
- Check the limit switch cams

The actuator is supplied with power but does not operate

- Verify the line voltage supplied to the actuator; check that the line voltage matches with the rating on the actuator's nameplate.
- Check that the actuator torque is greater than the valve torque
- Check the limit switch cams
- Check that the torque switches have not been tripped
- Check the mechanical travel stop adjustment
- Verify that the actuator against the rotation of the valve (standard units are counter-clockwise rotation to open)
- Check for any corrosion and condensation that any of the electrical or mechanical devices have not been contaminated
- Verify that coupler/bracket is correctly installed and is not causing any binding

Actuator runs erratically

- Check the ambient temperature
- Verify that the duty cycle has not been exceeded
- Check the position of manual override lever

Optional edquipment(s)

- 1) Potentiometer Current Position Transmitter
 - Check the resistance value
 - Check potentiometer gear for jamming
 - Check ZERO and SPAN calibration
 - Check the board for any damage
- 2) Current Position Transmitter
 - Verify the input signal
 - Check the configuration of the dip switches
 - Check the board for any damage

8. DIMENSIONS

8.1 5630-006 On/Off Type

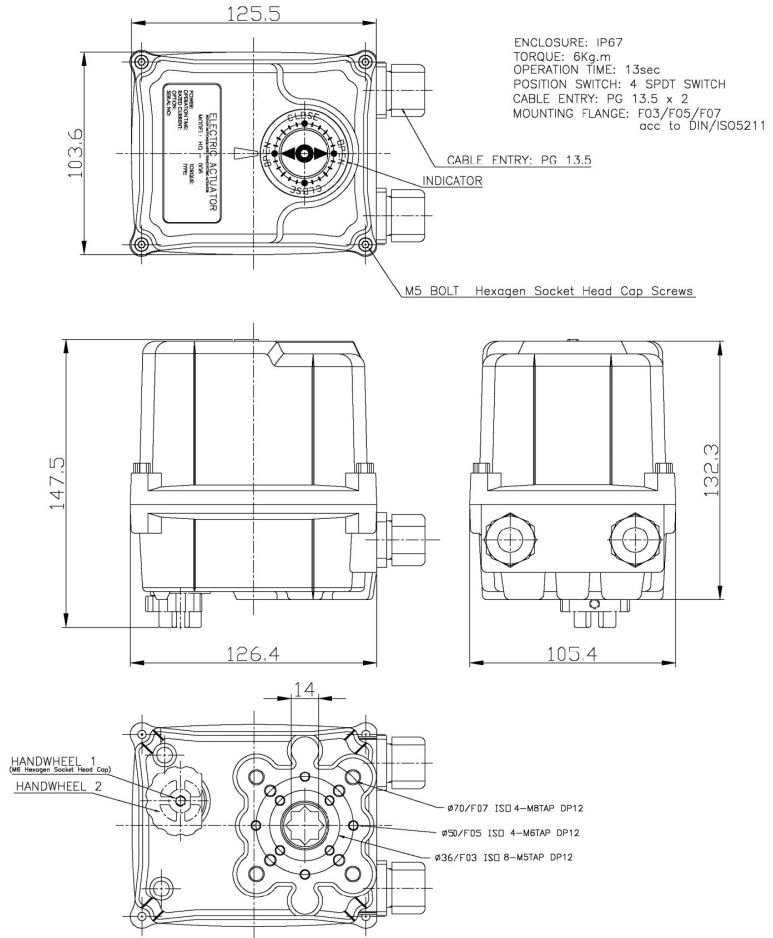

8.2 5630-006 PCU Type

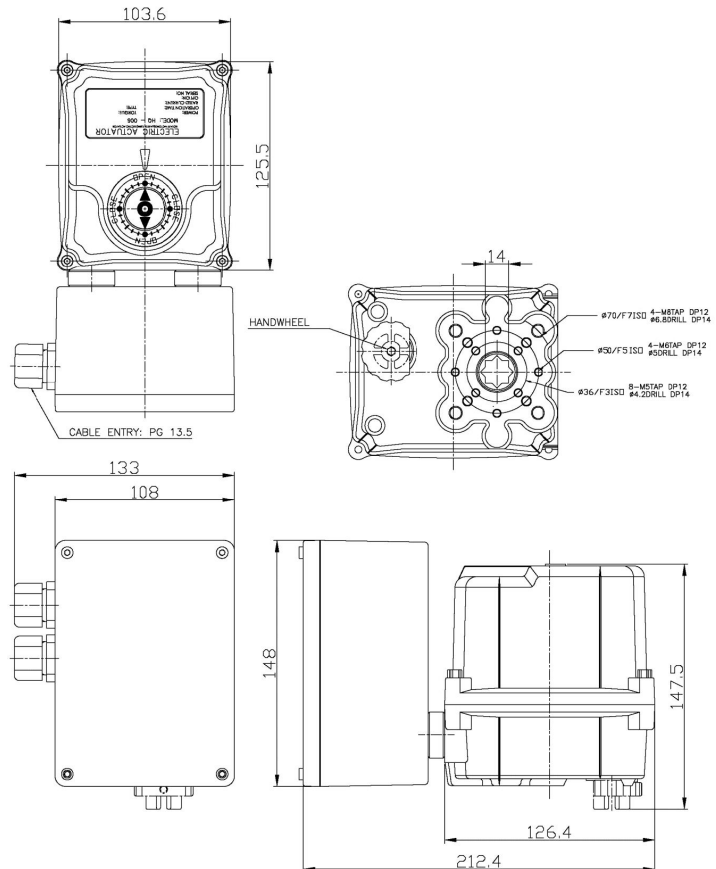

NOTE: FOR MORE INFORMATION REGARDING THIS PRODUCT, PLEASE CONTACT THE MANUFACTURER OR YOUR SUPPLIER..