



Know-how makes the difference



# ELECTRICAL ACTUATOR

## TYPE 5630-008-300

Installation, Operation, Maintenance Manual



With Dansk Ventil Center A/S as your business partner, you are always guaranteed a wide and well sorted product range and a unique technical know-how

Product development is a key factor for DVC A/S, ensuring you the best products at any time



## INDEX

1 INTRODUCTION .....	1
2 PRODUCT IDENTIFICATION.....	1-3
3 GENERAL INFORMATION AND FEATURES.....	3-5
4 INSTALLATION .....	6-14
5 OPERATION.....	14-15
6 MAINTENANCE.....	15
7 TROUBLE SHOOTING .....	16
8 INSTALLATION AND MAINTENANCE TIPS.....	16
APPENDIX I: TYPE 5630-015 CODING SYSTEM (FOR CSA).....	17
APPENDIX II: WIRING DIAGRAM.....	18-20
APPENDIX III: GROUNDING.....	21-22

## 1. INTRODUCTION

### 1.1 Purpose

The purpose of this manual is to introduce and explain the installation, operation and maintenance of 5630-015 electric actuators.

### 1.2 Safety notices

Safety notices in this manual outline precautions the user must take to reduce the risk of personal injury and damage to the equipment. The user(s) must read these instructions before the installation, operation or maintenance of the 5630-Series electric actuators.

 **DANGER:** Refers to personal safety. Alerts the user to danger or harm. The hazard or unsafe practice could result in severe injury or death.

 **WARNING :** Refers to personal safety. Alerts the user to potential danger. Failure to follow warning notices could result in personal injury or death.

 **CAUTION** Directs the user's attention to general precautions that, if not followed, could result in personal injury and/or equipment damage.

NOTE: Highlighted information is critical to the user's understanding of the actuator's installation and operation.

## 2. PRODUCT IDENTIFICATION

### 2.1 Product Identification

The actuator name plate is located on the opposite side of the conduit entry. The name plate contains the following:

#### 2.1.1 Marking

##### A) General

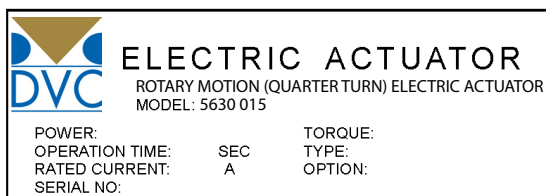

DVC logo (trade mark)

Model

Electrical Power Supply

Torque

Operating time (Seconds)



Type

Rated current

Option

Serial No.

B) Explosion Proof

 ELECTRIC ACTUATOR	MODEL : MOTOR :           W     P POWER :           V     PH ⚠ WARNING : DO NOT OPEN WHEN AN EXPLOSIVE GAS ATMOSPHERE MAY BE PRESENT.	SERIAL No.: YEAR : CABLE ENTRY TEMP : MAX 100°C CABLE ENTRY SIZE : 2xNPT3/4" or 2xM25	  KEMA 06ATEX2085X 0344 II2G Ex d IIB T4 Gb IECEX DEK 11.0098X Ex d IIB T4 Gb -20°C ≤ T <sub>a</sub> ≤ +60°C
--	--	--	--

- |  |  |
|--|--|
| <input type="checkbox"/> DVC logo (trade mark)   | <input type="checkbox"/> CE (ATEX) mark                                |
| <input type="checkbox"/> Model                   | <input type="checkbox"/> Motor specification                           |
| <input type="checkbox"/> Electrical power supply | <input type="checkbox"/> Ambient temp.                                 |
| <input type="checkbox"/> Serial No.              | <input type="checkbox"/> KEMA/DEKRA ATEX & IECEX Certification numbers |
| <input type="checkbox"/> Manufacturer's address  | <input type="checkbox"/> Warning                                       |

2.1.2 Certification

A) KTL (Korea Testing Laboratory)

- 5630-008      Certification No: 1454-051  
IP68  
Applied Standard: KS C IEC 60529(2002) & IEC 60529(2001)
  
- 5630-015/020      Certification No: 1454-165  
IP68  
Applied Standard: KS C IEC 60529(2002) & IEC 60529(2001)
  
- 5630-030/050/060      Certification No: 1454-255  
IP68  
Applied Standard: KS C IEC 60529(2002) & IEC 60529(2001)
  
- 5630-080/120      Certification No: 1471-272  
IP68  
Applied Standard: KS C IEC 60529(2002) & IEC 60529(2001)

B) KOSHA (Korea Occupational Safety & Health Agency) TYPE 5630-008

- 5630-008      Certification No: 2002-1034-Q1  
EX d IIB T4 IP67  
Applied Standard: Industrial Safety & Health Law Article 33
  
- 5630-015/020      Certification No: 2002-1035-Q1  
EX d IIB T4 IP67  
Applied Standard: Industrial Safety & Health Law Article 33
  
- 5630-030/050/060      Certification No: 2002-1036-Q1  
EX d IIB T4 IP67  
Applied Standard: Industrial Safety & Health Law Article 33
  
- 5630-080/120      Certification No: 2002-1037-Q1  
EX d IIB T4 IP67  
Applied Standard: Industrial Safety & Health Law Article 33

C) Lloyd (Heat Resistance Test) 5630-020  
 Coat Material: FR coating (intumescent)  
 Temp. / Time: 250±5°C / 2.5hr  
 Test Place: Fire Insurer's Laboratories of Korea (FILK)

D) KEMA 5630-Series: 5630 . . . 3 . 0 . . . 0  
 CE 0344 II2G  
 Ex d IIB T4 Gb IP67  
 KEMA 06 ATEX2085 X  
 Ambient Temperature: -20°C to +60°C

E) IECEX  
 5630-Series: 5630 . . . 3 . 0 . . . 0  
 IECEX DEK 11.0098X  
 Ex d IIB T4 Gb  
 Ambient Temperature: -20°C to +60°C

## 2.2 KEMA/DEKRA Flameproof Certification

5630-Series: 5630 . . . 3 . 0 . . . 0 1)

IECEX DEK 11.0098X

Ex d IIB T4 Gb IP67

Ambient Temperature: -20°C to +60°C

Cable entry: 2xNPT 3/4 Female or 2xM25 Female ATEX: EN 60079-0:2009, EN 60079-1:2007 IECEx: IEC60079-0:2007, IEC 60079-1:2007

NOTE:  Refer to Appendix I: 5630-Series Coding System

- Sealing devices must be used and shall be fitted directly at the enclosure wall when using conduit.
- Cable glands shall be suitable for the environment and shall be certified as flameproof if used in Zone 1 application.
- Cable glands and conduit to be installed shall be a minimum of 6 full threads and the length of the thread shall be a minimum of 8mm.
- The maximum temperature of cable entry is 100°C. Heat resistance wire is recommended when you install.
- EX d certified cable glands suitable for 100°C must be used.
- Users should confirm all information about dimensions of flamepath with the manufacturer.
- Information about the materials and the allowance of LCU fasteners:
  - Fasteners with yield stress  $\geq$  210MPa (stainless steel)
  - Bolts type: M5\*0.8, M6\*1, M8\*1.25, M10\*1.5, M12\*1.75 (Tolerance fit 6g)
- Cable connection: refer to Appendix II (Wiring Diagram).
- For cable entries or conduit entries that are not used, the user or installer shall close them by using certified blanking elements (stopping plugs) so that the flameproof properties of the enclosure are maintained.
- Always ground the enclosure in accordance with local electric codes. The most effective enclosure grounding method is a direct connection to earth ground with minimal impedance. Methods for grounding the enclosure include:
  - Internal ground connection: The internal ground is located in the terminal block
  - External ground connection: The ground lug is located on the center of cable entries
  - For more information, refer to Appendix III (Grounding)

## 2.3 Initial Inspection

Upon receipt of the actuator, the user should inspect the condition of the product and ensure that product specification stated in the name plate matches with the order sheet.

- Remove the packing wrap or wooden box carefully. Inspect the product for any visual damage that may have occurred during shipment.
- Check the product specification with product ordered. If a wrong product has been shipped, immediately report to your supplier.

## 2.4 Storage

Actuators must be stored in a clean, cool and dry area. The unit should be stored with the cover installed and the conduit openings sealed. Storage must be off the floor, covered with a dust protector. When actuators are stored outdoor, they must be stored off the ground, high enough to prevent from being immersed in water or buried in snow.

## 3. GENERAL INFORMATION

TYPE 5630-series electric actuators are designed for the operation of quarter turn industrial valves, such as butterfly valves and ball valves. The actuator torque outputs range from 80 Nm to 3,000 Nm (690 In-Lbs to 25,900 in-Lbs). Currently eleven models are available.

### 3.1.1 Explosion Proof (CSA Approval)

5630-SERIES TYPE	A-T CONTROLS TYPE	MAX OUTPUT TORQUE KG.M	OPERATING TIME (SEC.) 90°	MAX. BORE SIZE MM	MOTOR FRAME SIZE W*F	RATED CURRENT (A) 50/60Hz				NUMBER OF HANDLE TURN N	WEIGHT KG
						AC (1 PHASE)		DC			
						110 V	220 V	12 V	24 V		
5630-008	XE-690	8	13/16	Ø20	15*70	0.96/0.97	0.47/0.46	6.4	2.5	10	7.4
5630-010	XE-860	10	17/20	Ø20	15*70	0.96/0.97	0.47/0.46	6.4	2.5	10	7.4
5630-015	XE-1350	15	21/25	Ø22	40*80	1.51/1.62	0.72/0.84	N/A	8.8	11	16.6
5630-020	XE-1700	20	21/25	Ø22	40*80	1.51/1.62	0.72/0.84	N/A	9.8	11	16.6
5630-030	XE-2640	30	26/31	Ø35	40*90	1.37/1.67	0.68/0.81	N/A	10.6	13.5	22.0
5630-050	XE-4400	50	26/31	Ø35	90*90	4.27/3.56	1.37/1.27	N/A	N/A	13.5	23.0
5630-060	XE-5200	60	26/31	Ø35	90*90	4.27/3.56	1.37/1.27	N/A	N/A	13.5	23.0
5630-080	XE-6900	80	31/37	Ø45	180*90	3.47/4.45	1.81/2.32	N/A	N/A	16.5	29.0
5630-120	XE-10500	120	31/37	Ø45	180*90	3.47/4.45	1.81/2.32	N/A	N/A	16.5	29.0
5630-200	XE-17500	200	93/112	Ø65	180*90	3.47/4.45	1.81/2.32	N/A	N/A	49.5	75.0
5630-300	XE-25900	300	93/112	Ø65	180*90	3.47/4.45	1.81/2.32	N/A	N/A	49.5	75.0

### 3.1.2 EXPLOSION PROOF TECHNICAL DATA (OPTIONAL)

Enclosure Rated	Weatherproof IP67, NEMA 4 & 6
Enclosure	High grade aluminum alloy, corrosion coated
Power Supply	110 / 230V AC 1 Ph 60/50Hz 12/24V DC 50/60 Hz
Duty Type	S4 70% / S2 30min (IEC 60034)
Motor	Squirrel caged induction motor
Limit Switches	2 x open/close SPDT, 250V AC 16A rating
Auxiliary Limit Switches	2 x open/close SPDT, 250V AC 16A rating (except 5630-008)
Torque Switches	Open/Close SPDT, 250VAC 10A rating (except 5630-008)
Stall Protection	Built-in thermal protection.
Travel Angle	90 degree +/- 10%
Indicator	Continuous position indicator
Manual Override	Declutchable manual override
Self Locking	By means of worm gear
Mechanical Travel Stops	2 x external adjustable mechanical travel stops
Space Heater	10w ceramic housed
Conduit Entries	2 x PF3/4", 2xM25 or 2xNPT 3/4 for EXA (user selection)
Lubrication	Moly EP Grease
Ambient Temp.	-20°C ~ + 60°C (except on CPT & PCU board)
External Coating	Powder coated polyester, thickness Max. of 2mm

### 3.1.3 OPTION TECHNICAL DATA (OPTIONAL)

EXA	Explosion proof enclosure (Ex d II B T4 Gb IP67)
WTA	Watertight Enclosure (IP68 10m / 72hr)
PIU	Potentiometer Unit (0~1KΩ)
PCU	Proportional Control Unit (input, output 0~10V DC, 4~20mA)
CPT	Current Position Transmitter (output 4~20mA)

### 3.1.4 Duty Cycle<sup>2)</sup>

Duty cycle rated IEC60034 – S4 70% / S2 30 min. Exceeding the actuator's rated duty cycle may cause thermal overload.

NOTE: <sup>1)</sup>TYPE OF DUTY ACCORDING TO VDE 0530 / IEC 60034-1

SHORT – TIME DUTY S2	INTERMITTENT DUTY S4
The operation time at a constant load is short, so that thermal equilibrium is not reached. The pause is long enough for the machine to cool down to ambient temperature. The duration of the short –time operation is limited to 15min (10min, 30min)	The duty is a sequence of identical cycles which consist of starting time, operation time with constant load and rest period. The rest period allows the machine to cool down so that thermal equilibrium is not reached. The relative on-time at S4-25% or S4-50% is limited to 25% and 50% respectively.

### 3.1.5 Heater

Condensation in the actuator is possible due to wide fluctuation of the ambient temperature. The heater integrated in the control unit prevents this in general.

- 2W, Ceramic housing with thermostat to prevent over heating with 60°C set temperature.

Heating Element	Self-regulating	
Voltage Range (5630-008~010) (based on the control power)	110 V AC	5W 4.5VKΩJ
	230 V AC	5W 18VKΩJ
	24V DC	5W 4.200ΩJ
	12V DC	5W 47ΩJ
Voltage Range (5630-015~300) (based on the control power)	110 V AC	10W 2KΩJ
	230 V AC	10W 8KΩJ
	24V DC	10W 100ΩJ
	12V DC	10W 27ΩJ



### 3.1.6 Hand Wheel and Declutching

5630-Series actuators are provided with a declutchable manual override system.

- In order to manually operate the actuator, pull the manual override engagement lever towards the hand-wheel until it remains in position.
- Turn the hand-wheel until the valve reaches the required position.
- Turn clockwise to close and counter-clockwise to open.

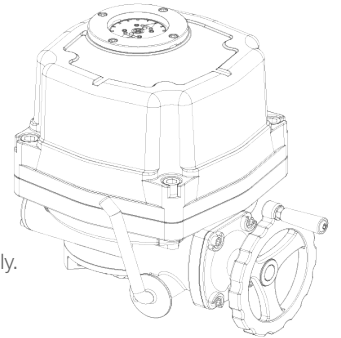

NOTE: The override engagement level returns automatically to auto-position when the actuator is operated electrically.

### 3.1.7 LUBRICATION

5630-series are totally enclosed units with permanent lubricated gear train (Moly EP Grease). Once installed, lubrication should not be required. However, periodic preventative maintenance will extend the operating life of the actuator.

## 3.2 External Parts for Standard Models

### 3.2.1 5630-008 ~ 5630-120

EXTERNAL PARTS 008-120
Top Cover
Body
Lever
Hand Wheel
Mechanical Travel Stops
Window & Indicator
Conduit Entries (Pg 3/4")
Base

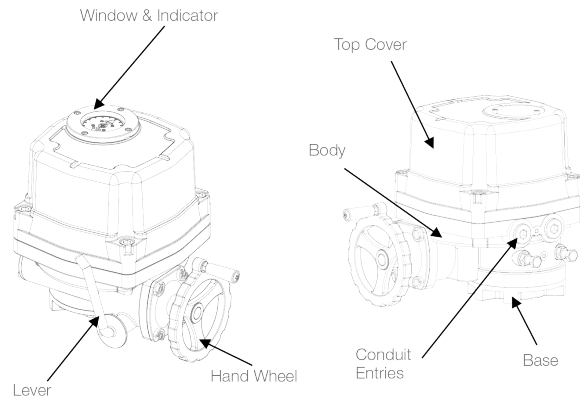

### 3.2.2 5630-200 ~ 5630-300

EXTERNAL PARTS 200-300
Top Cover
Body
Lever
Hand Wheel
Mechanical Travel Stops
Window & Indicator
Conduit Entries (Pg 3/4")
Base
Driving Bushing
Gear Box

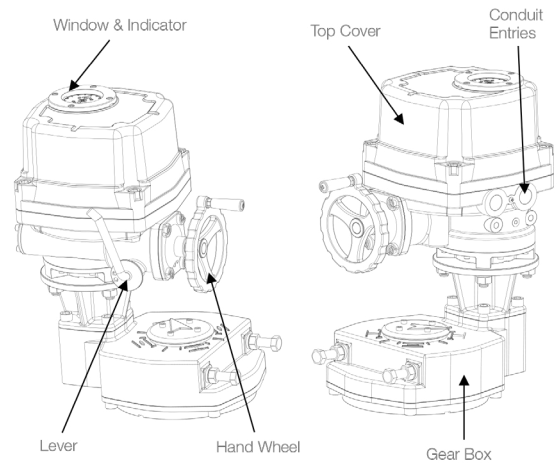

## 3.3 Internal Parts for standard Models

### 3.3.1 5630-008 ~5630-300

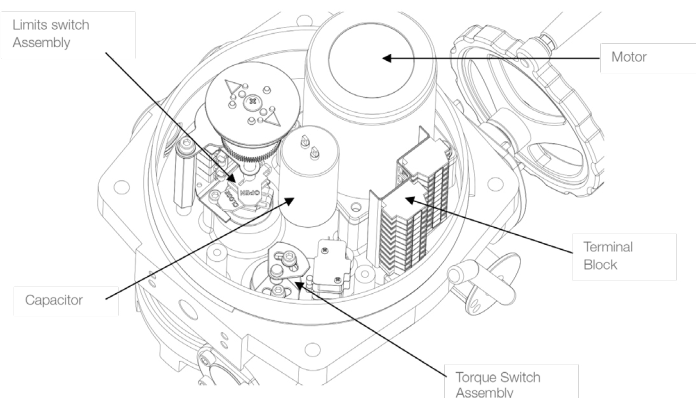

NOTE: 5630-008 ~5630-010 does not contain Torque Switch Assembly.

## 4. INSTALLATION

### 4.1 PRE-INSTALLATION

#### 4.1.1 USE IN GENERAL SERVICE

Verify the actuator's nameplate to ensure correct model number, torque output, operating speed, voltage and enclosure type before installation or use. It is important to verify that the torque output of the actuator is appropriate for the torque requirements of the valve and that the duty cycle of the actuator is appropriate for the intended application.

#### 4.1.2 Use in potentially explosive atmosphere

Model	5630-...3.0...0 <sup>3)</sup>
Type Of Enclosure	II 2G EEx d IIB T4
Ambient Temperature	-20°C ~+60°C

Installation, commissioning, maintenance, repairs and modification work must only be performed by qualified personnel with extensive knowledge on how to work on explosion-proof electrical equipment.

NOTE: <sup>3)</sup>Further information can be found from the 5630-Series electric actuator catalogue. Refer to the Cl.2.2 in this manual.

**WARNING:** Read this installation, operation and maintenance manual carefully and completely before attempting to install, operate, or trouble shoot the 5630 actuator.

### 4.2 ACTUATOR MOUNTING

NOTE: Prior to mounting, the actuator must be checked for any damage. Damaged parts must be replaced by original spare parts.

Mounting is most easily done with the valve shaft pointing vertically upward. But mounting is also possible in any other position, the actuator may be mounted in any position. The 5630-series electric actuators are supplied with a female drive output. The ISO 5211 bolt patterns are provided for actuator mounting. The actuator drive bush is removable for easy assembly.

It is mandatory for the actuator to be firmly secured to a sturdy mounting bracket or directly mounted to the valves' ISO mounting pad. High tensile bolts or studs with spring locking washers must be used.

The valve output shaft must be in line with the actuator output drive to avoid side-loading the shaft. To avoid backlash, flexibility in the mounting bracket or mounting should not be allowed.

**CAUTION:**

- Do not attempt to work on your 5630-series actuator without first shutting off the incoming power
- Do not attach ropes or hooks to the hand wheel for the purpose of lifting by hoist

#### 4.2.1 Actuator Mounting Base Details (ISO 5211)

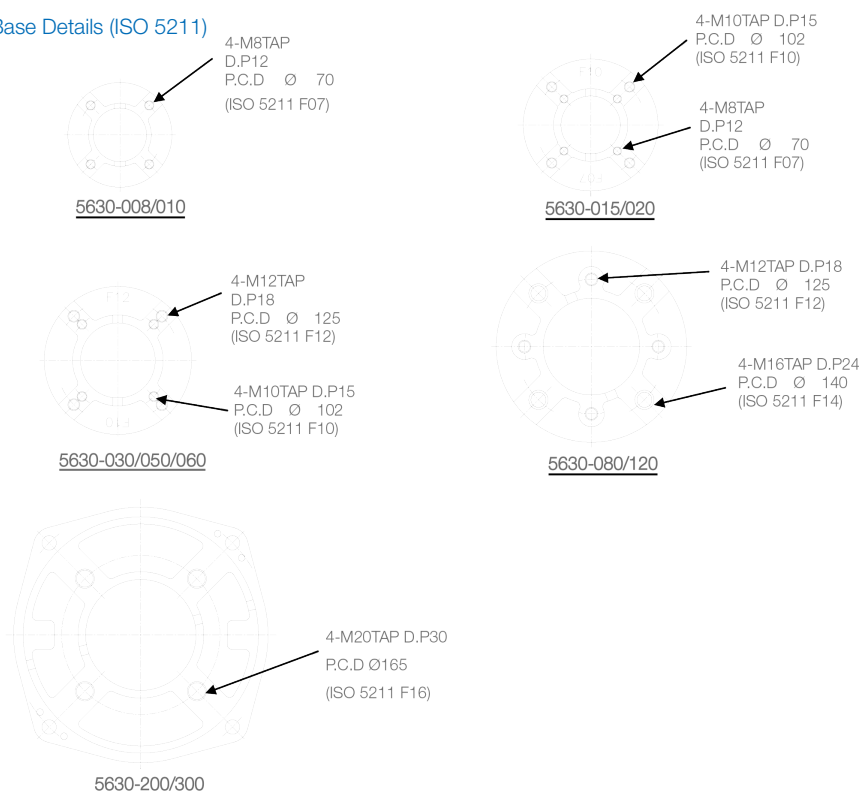

#### 4.2.2 Actuator Drive Bushing

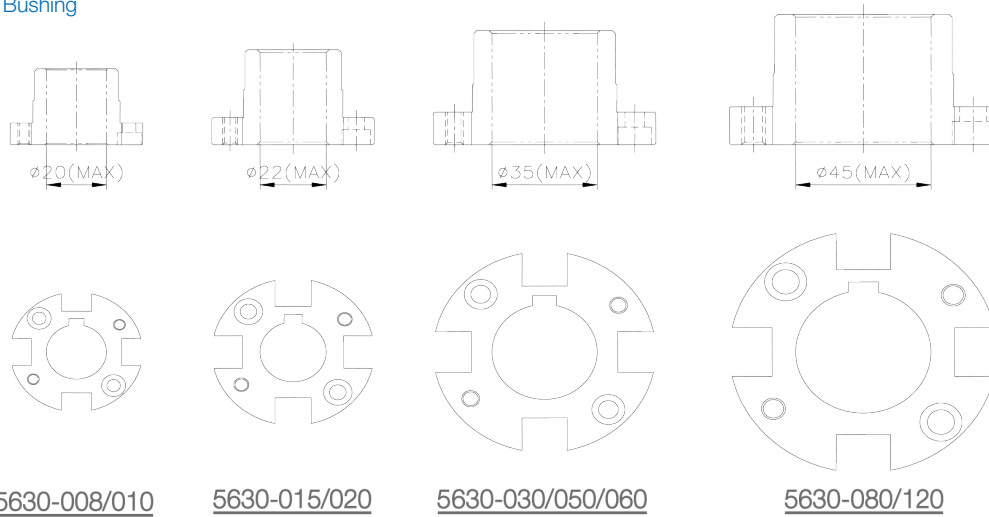

#### 4.3 LIMIT SWITCH SETTING

- Manually rotate the hand wheel of the actuator to fully closed position
- Using a hex wrench, loosen the set screw in the CLOSE limit switch cam
- Rotate the CLOSE cam towards CW limit switch level until the switch 'clicks' (see Figure 1)
- Tighten the set screw with the hex wrench
- Manually rotate the hand wheel of the actuator to opened position
- Using the hex wrench, loosen the set screw in the OPEN limit switch cam
- Rotate the OPEN cam towards CCW limit switch level until the switch 'clicks' (see Figure 2)
- Tighten the set screw with the hex wrench

**⚠ DANGER: HAZARDOUS VOLTAGE.** Make sure all incoming power is disconnected before setting the limit switch

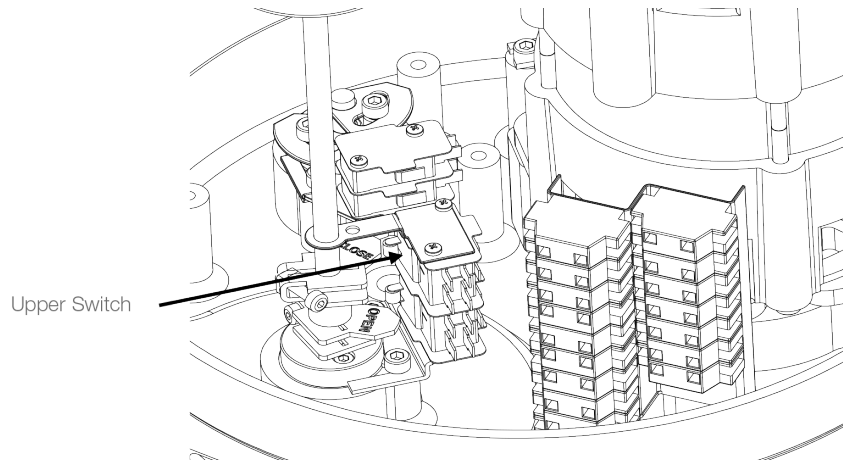

Figure 1: Close Cam Setting

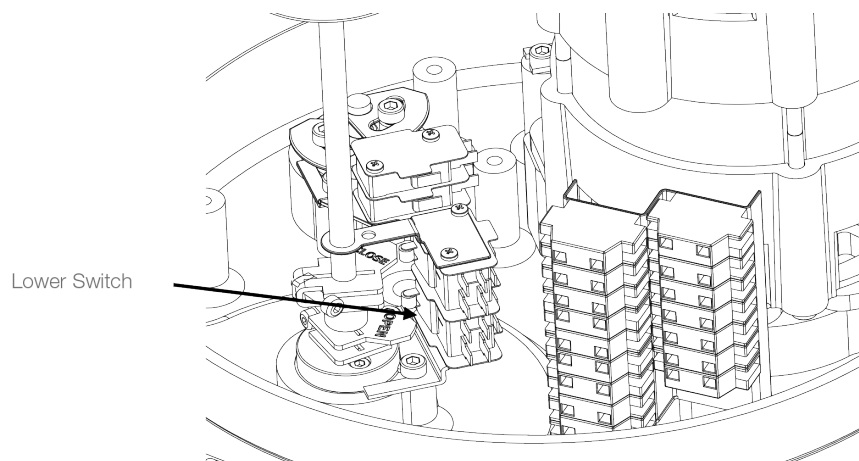

Figure 2: Open Cam Setting



#### 4.4 TORQUE SWITCH SETTING

Torque spring, which detects the variation of torque during the operation, is installed to prevent damaging the valve and actuator under overload condition. Once the actuator is overloaded, the torque switch trips, and the actuator stops immediately.

The torque switches are set by manufacturer on the production site. If re-setting is necessary, Please contact the 5630-series service representative before setting the torque switch.

**⚠ CAUTION:** Do not reset torque switch to a setting higher than the maximum setting stated by the manufacturer.

#### 4.5 COUNTER-CLOCKWISE TO CLOSE SETTING

Standard actuators are normally set to clockwise rotation to close. However, the rotation can be reversed to counter-clockwise to close by simply reconfiguring the wiring as follows:

- Reverse wiring in the main terminal block: 9 & 10 as well as 11 & 12.
- Adjust the visual indicator to suit the counter-clockwise rotation.

If a PCU card is installed:

- Reverse P1 (orange) and P3 (grey) on the PCU board.
- Move the actuator manually to half-open position and push the auto-reset button once.

#### 4.6 MECHANICAL TRAVEL STOP ADJUSTMENT

- Loosen both (open and close) travel stopper bolt nuts by 3-4 threads.
- By the turning the hand wheel, manually operate the actuator so that it is in closed position until it makes a contact with the closed limit switch.
- Tighten the close travel stopper bolt until it contacts the 2nd worm wheel (in this position the close travel stopper bolt should not be able to travel any further).
- Loosen back the close travel stopper bolt by one turn and tighten the close travel stopper bolt nut.
- Repeat the same operation for setting of the open travel stopper bolt.

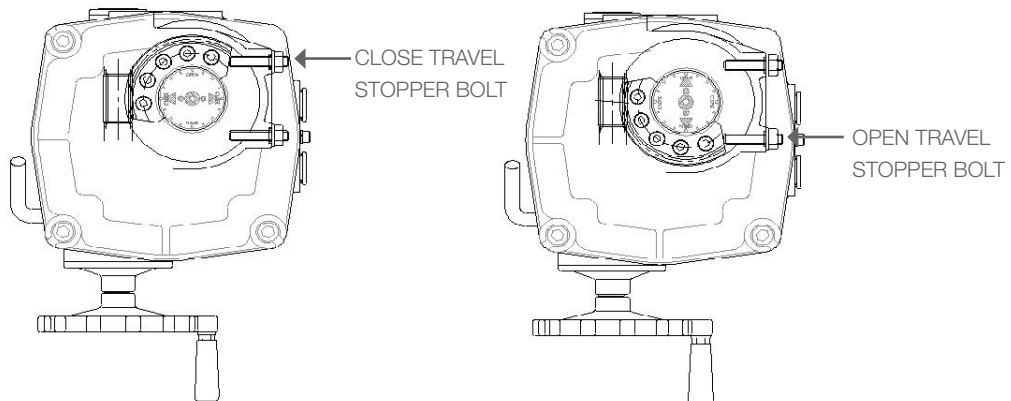

#### 4.7 SETTING POTENTIOMETER (REPLACEMENT AND SETTING)

The potentiometer has been calibrated at factory. However, if re-calibration is required, proceed as follows:

- Manually rotate the hand wheel of the actuator to fully closed position.
- While measuring the resistance between P1 (orange) and P2 (grey), gently rotate the Potentiometer Gear until it reaches between 80 - 120  $\Omega$  (100  $\Omega$  preferred).
- Engage the Potentiometer Gear into the Point Shaft Gear and use an hex-wrench to tighten the screw.

**⚠ DANGER: HAZARDOUS VOLTAGE.** Make sure all incoming power is disconnected before setting the potentiometer

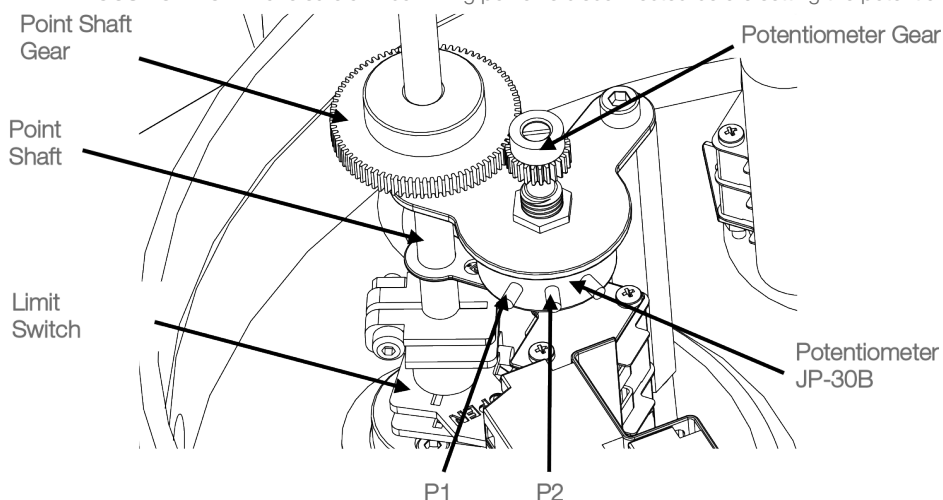

#### 4.8 CURRENT POSITION TRANSMITTER - CPT (OPTIONAL)

The potentiometer is used for the actuator signal feedback. It reads a resistance value corresponds to the current position of the actuator and transfers to CPT card. The CPT indicates the current position of the actuator throughout the stroke by a 4 – 20mA output signal.

##### 4.8.1 Standard Features

Model	CPT
Power	230(110)V AC, 50/60HZ 2VA MAX
Output Signal	4~20mA
Output Impedance	750Ω MAX
Resolution	MIN 1/1000
Position Conversion Accuracy	±0.5 ~ ±1.5%
Ambient Temperature	-20°C TO +70°C
Ambient Humidity	90% RH MAX (NON-CONDENSING)
Dielectric Strength	1500V AC 1 MIN (INPUT TO OUTPUT TO POWER GROUND)
Insulation Resistance	Above 500V DC 30MΩ
Vibration	10g, 0~34Hz



DANGER:

HAZARDOUS VOLTAGE. Make sure all incoming power is disconnected before setting the actuator

##### 4.8.2 Calibration of Zero and Span - CPT

The settings of Zero and Span have been calibrated at the factory. However, if re-calibration is required, proceed as follows:

- Use the manual override to drive the actuator to a half open position.
- Apply power (or use the manual override) to drive the actuator to its fully closed position (clockwise rotation).
- When the actuator is in the fully closed position, adjust the ZERO dial on the CPT board until a reading of 4mA is achieved.
- Apply power (or use the manual override) to drive the actuator to its fully open position (counter-clockwise rotation).
- When the actuator is in the fully open position, adjust the SPAN dial on the CPT board until a reading of 20mA is achieved.

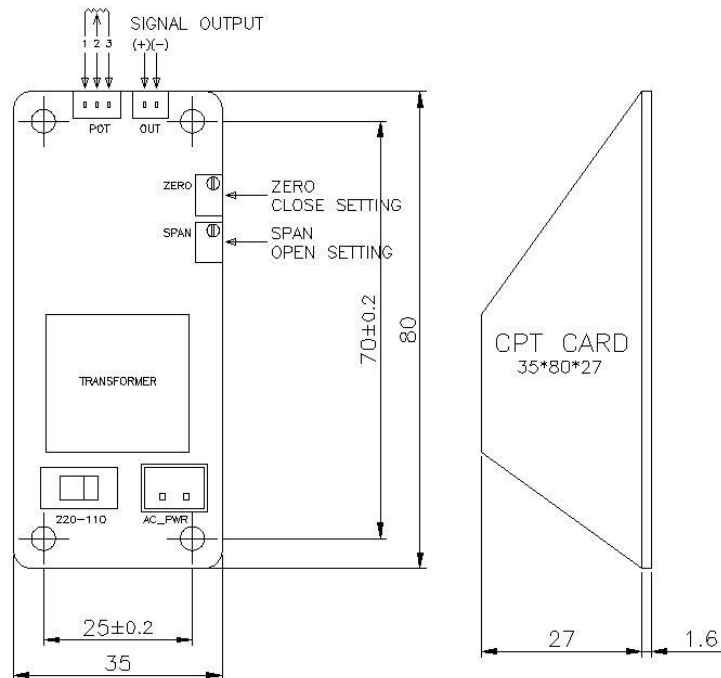

#### 4.9 PROPORTIONAL CONTROL UNIT (PCU-A)

PCU-Rev-4 High Performance Controller, using 10 bit A/D converter and 8bit microprocessor technology

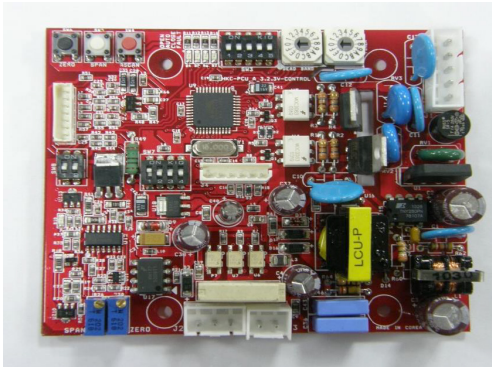

The factory settings of the PCU card are normally set according to the customer requirements at the time of order. However, we strongly recommend that input power, signal input selection and DIP switches are to be verified prior to the actuator start up.

**⚠ CAUTION: HAZARDOUS VOLTAGE. TURN OFF ALL POWER BEFORE SETTING YOUR ACTUATOR.**

PCU-REV-4 FEATURES	
Model	PCU-Rev-4
Power	85 ~ 260 VAC Free Voltage $\pm$ 10%, 50/60Hz 4 VA Max
Input Signal	4~20mA DC, 1~5V DC, 2~10V DC, 0~5V DC, 0~10V DC
Input Impedance	250 $\Omega$
Output Signal	4~20mA DC, 1~5V DC, 2~10V DC, 0~5V DC, 0~10V DC
Output Impedance	750 $\Omega$ Max
Output Contact	1 (Fault monitor)
Delay Time Adjustment	0.05~7.5 seconds
Deadband Adjustment	0.12mA DC Max
Resolution Adjustment	0.0625~1mA (0.0625mA + step no. x 0.0625mA, 15 steps total)
Ambient Temperature	-10°C to +70°C
Ambient Humidity	90% RH Max (non-condensation)
Dielectric Strength	1500V AC 1 Minute (input to output, power to ground)
Insulation Resistance	Minimum 500V DC 30M $\Omega$

#### 4.10 PROPORTIONAL CONTROL UNIT (PCU-D)

PCU-Rev-D1 High Performance Controller, using 10 bit A/D converter and 8bit microprocessor technology

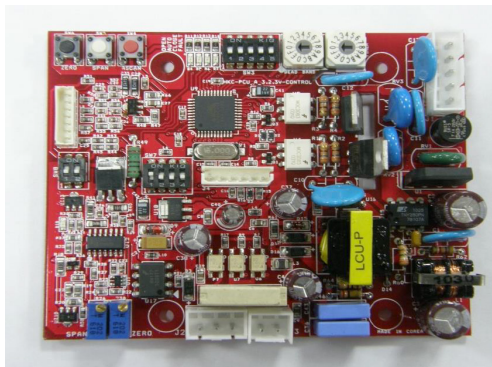

The factory settings of the PCU card are normally set according to the customer requirements at the time of order. However, we strongly recommend that input power, signal input selection and DIP switches are to be verified prior to the actuator start up.

**⚠ CAUTION: HAZARDOUS VOLTAGE. TURN OFF ALL POWER BEFORE SETTING YOUR ACTUATOR.**

PCU-REV-4 FEATURES	
Model	PCU-Rev-D1
Power	24V DC Voltage $\pm$ 15% (36V DC Max)
Input Signal	4~20mA DC, 1~5V DC, 2~10V DC, 0~5V DC, 0~10V DC
Input Impedance	250 $\Omega$
Output Signal	4~20mA DC, 1~5V DC, 2~10V DC, 0~5V DC, 0~10V DC
Output Impedance	750 $\Omega$ Max
Output Contact	1 (Fault monitor)
Delay Time Adjustment	0.05~7.5 seconds
Deadband Adjustment	0.12mA DC Max
Resolution Adjustment	0.0625~1mA (0.0625mA + step no. x 0.0625mA, 15 steps total)
Ambient Temperature	-25°C to +80°C
Ambient Humidity	90% RH Max (non-condensation)
Dielectric Strength	1500V AC 1 Minute (input to output, power to ground)
Insulation Resistance	Minimum 500V DC 30M $\Omega$

##### 4.10.1 LED Signal Indication

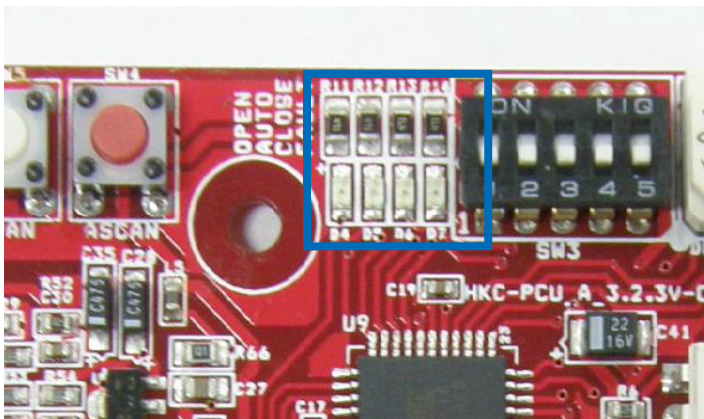

LED	STATE	INDICATION
Blue	On	Power On (Auto)
	Flickering	Auto Calibrating
Green	On	Fully Closed
	Flickering	Closing
Red	On	Fully Open
	Flickering	Opening
Yellow	On Flickering	Manual Mode:
		Fault Indication, Either:
		- No Input Signal - Wrong Input Wiring - Wrong Piu Setting

## 4.10.2 Setting PCU Functions

### A) Selecting Input Signal

- User can select different types of input signal by adjusting the DIP switches as follows:

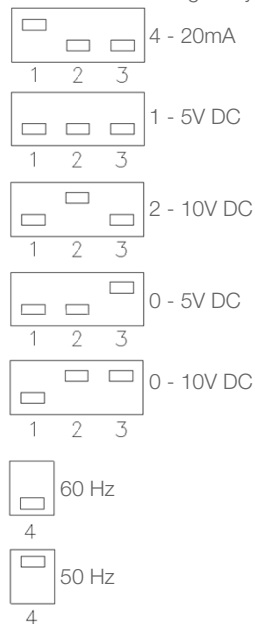

Input Signal Switch: →

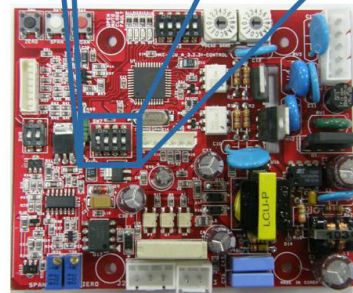
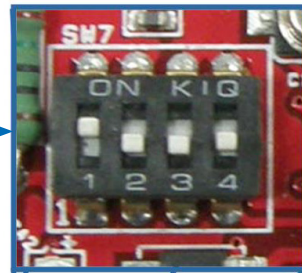

NOTE: IF NOT SPECIFIED, THE FACTORY SETTING OF THE INPUT SIGNAL IS 4 - 20mA.

### B) Selecting Output Signal

- User can select different types of output signal by adjusting the DIP switch as follows:

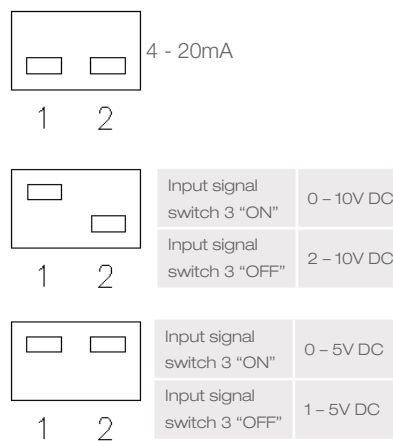

Output Signal Switch: ←

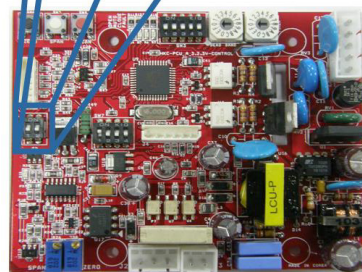
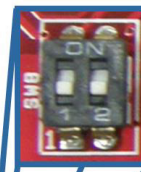

NOTE: IF NOT SPECIFIED, THE FACTORY SETTING OF THE OUTPUT SIGNAL IS 4 - 20mA.

### C) Fail Position Setting

- User can select the fail position of the actuator in case of control signal failure by adjusting the DIP switches as follows:

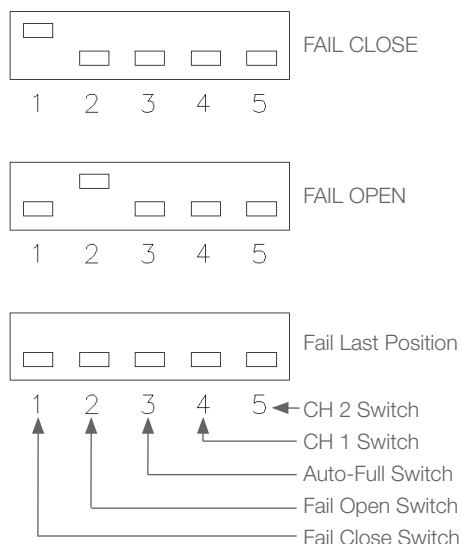

Fail Position Setting Switch →

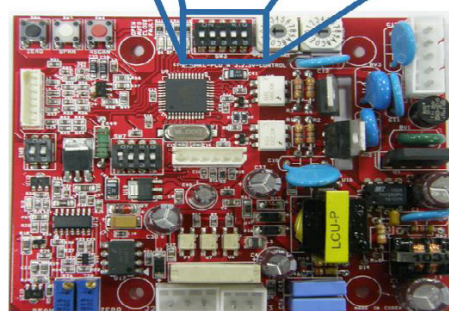
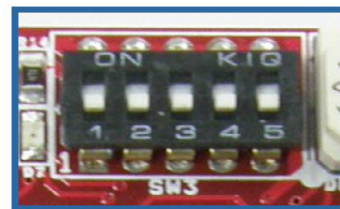



#### D) Special Signal Setting for Fully Open and Fully Closed

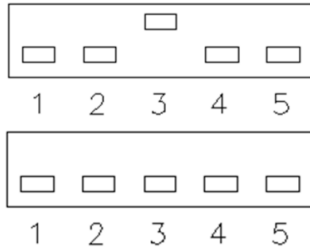

Auto-Full Switch (Switch 3) On (up)	Signal: 4.3mA Signal: 19.7mA	Fully Closed Fully open
--	---------------------------------	----------------------------

Auto-Full Switch (Switch 3) Off (down)	Signal: 4.0mA Signal: 20.0mA	Fully Closed Fully open
--	---------------------------------	----------------------------

#### E) Auto Setting

- This function is used for automatic setting of the PCU card to the predefined limits.
- While the actuator is corrected mounted on the valve, check input power, input and output signal connections.  
Press ASCAN button once, regardless of the position of the actuator, then the actuator will perform the Auto Setting motion:

- 1) The blue LED flicker
- 2) Opening (the red LED flickering) for 5 seconds
- 3) Pause for 2 seconds
- 4) Fully closing (the green LED flickering)
- 5) Pause (the green LED on) for 3 seconds
- 6) Fully opening (the red LED flickering)
- 7) Pause (the red LED on) for 3 seconds
- 8) Moving back to the previous position

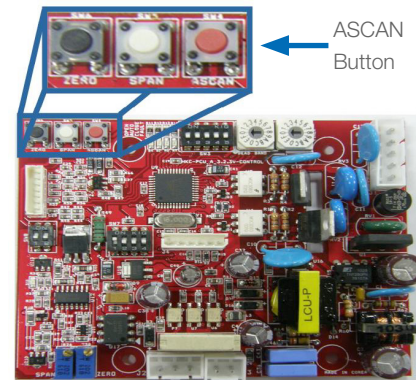

NOTE: Since the unit is already set at the factory, no further setting is required unless the user has adjusted the mounting state of Limit Switch or the Potentiometer.

#### F) Manual Operation

- This function allows the user to manually operate the actuator.
- To access this function, press the ZERO (black) and SPAN (white) buttons simultaneously for 2 seconds and the yellow LED will be lit to indicate that the actuator is in Manual Operation mode
- Pressing the ZERO button will move the actuator to close and pressing the SPAN button will move the actuator to open
- If no operation occurs within 5 seconds, the PCU automatically terminates the Manual Operation mode or alternatively press the ZERO and SPAN buttons simultaneously for 2 seconds. In either case, the yellow LED will be lit off to indicate the termination of the Manual Operation Mode.

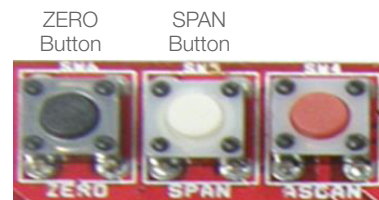

NOTE: During the Manual Operation mode, the input signal is ignored.

#### G) Customizing Set-points (CH 1 Switch)

- This function is used when the user wants to set different set-points for fully open and fully closed positions.

- For example, if the user wants to assign 5mA as the set-point for fully closed position, first of all switch-on (move up) the CH1 switch (switch 4). Supply a 5mA signal and push the ZERO button once. Hereafter, the actuator will acknowledge 5mA signal as the set-point for fully closed position and transmits 4mA feedback signal. Similarly, for setting the set-point for the fully open position, supply the desired signal (for example, 19mA) and push the SPAN button once. Switch-off (move down) the CH 1 switch to complete the setting.

SET-Points	ADJUSTABLE RANGE
Fully Closed	3-8 mA
Fully Open	16-21 mA



### H) Reversal Acting (CH 2 Switch)

- This function allows the user to reverse the input and output signals for the operation of the actuator.
- For standard operation (CH 2 switch down), the input signal of 4mA operates the actuator to fully close and the actuator transmits the output signal of 4mA. However, when CH 2 switch is on (move up) the input signal of 4mA operates the actuator to fully open and still transmits 4mA output signal. Manually move the actuator to half-open position and push ASCAN button once to execute the Auto Setting (see 4.10.2 E). Supply signal and check the operation.

CH 2 Switch (Switch 5) On (up)	4mA Fully open 20mA Fully closed
CH 2 Switch (Switch 5) Off (down)	4mA Fully open 20mA Fully closed

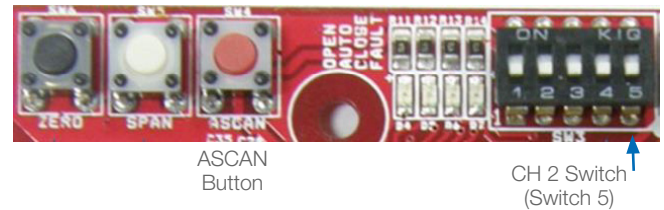

### I) Delay Time

- The actuator starts to move if and only if the change in the input signal value is greater than the resolution set value (see 4.10.2 J) and when the signal value is maintained for the duration of the delay time.
- This prevents malfunction of the actuator caused by unwanted signals in the input signal such as noise and interferences.
- Turning the Delay Time Dial in clockwise direction will increase the delay time (Range 0.05 to 7.5 seconds).

Dial	0	1	2	3	4	5	6	7
Sec	0.05	0.2	0.4	0.6	0.8	2.5	3.0	3.5
Dial	8	9	A	B	C	D	E	F
Sec	4.0	4.5	5.0	5.5	6.0	6.5	7.0	7.5

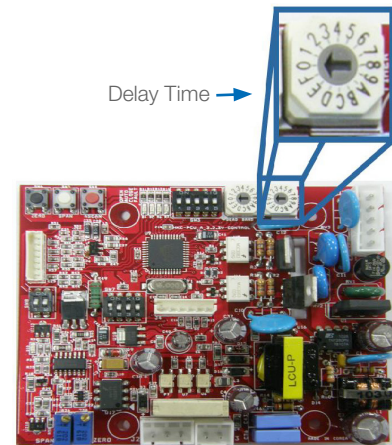

### J) Deadband

- The deadband adjusts the limits of the valve's deviation between an actual position and a target position. The deadband is set to 0.12mA DC Max.
- Deadband indicates the extent of the reaction on the input signal.
- Low resolution setting may cause the actuator to seek or to unnecessarily respond to a fluctuating input signal. If so, the deadband must be increased.
- Turning the Deadband Dial in clockwise direction will increase the deadband (Range 0.0625mA to 1mA).

Dial	0	1	2	3	4	5	6	7
mA	0.0625	0.125	0.1875	0.25	0.3125	0.375	0.4375	0.5

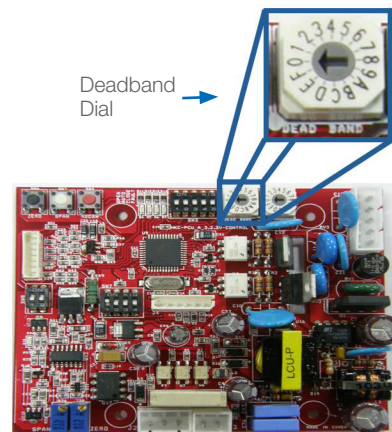

Dial	8	9	A	B	C	D	E	F
mA	0.5625	0.625	0.6875	0.75	0.8125	0.875	0.9375	1

## 4.11 AC/DC Multi-Board

### A) POWER OPEN AND CLOSE TERMINAL

- 1 POWER 24V AC/DC (DC + SIGNAL BLOCK)
- 2 NONE
- 3 NONE
- 4 OPEN SIGNAL
- 5 CLOSE SIGNAL
- 6 POWER 24V AC/DC (DC + SIGNAL BLOCK)

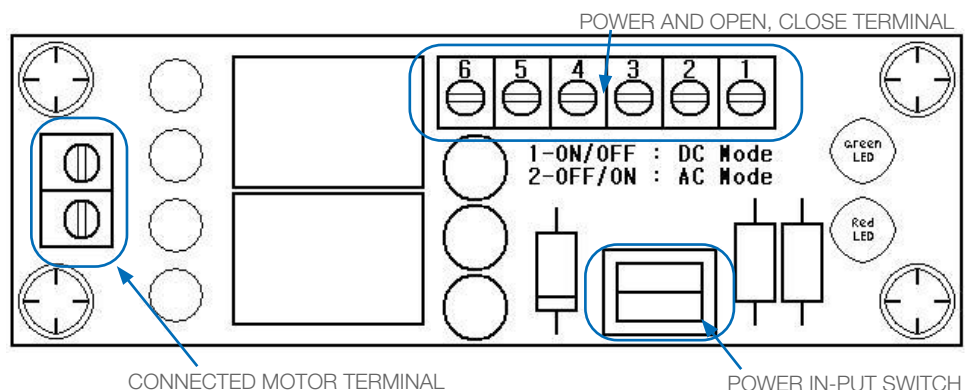



## B) Chooses switch for power signal

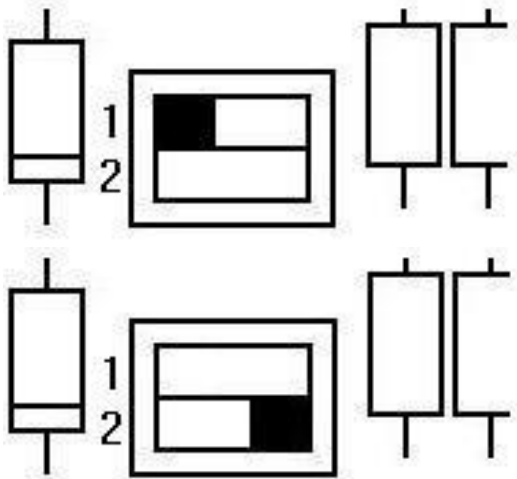

As using for AC Mode, switch 1 turn on "ON" and switch 2 turn off "OFF".

As using for DC Mode, switch 1 turn off, and switch 2 turn on.

\*NOTICE: Don't turn on both switch #1 and #2 at the same time it can result in damaged board.

## C) Motor connect Block

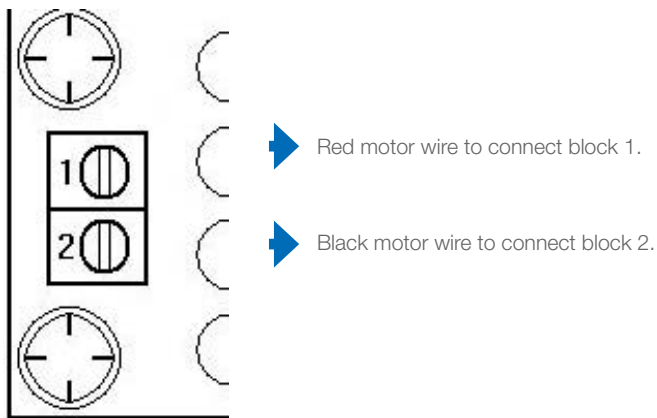

Red motor wire to connect block 1.

Black motor wire to connect block 2.

## 5.0 OPERATION

### 5.1 ELECTRICAL CONNECTIONS AND PRELIMINARY TEST



#### WARNING:

- When working in potentially explosive areas, observe the European Standards EN 60079-14 "Electrical Installation in Hazardous Areas" and EN 60079-17 "Inspection and Maintenance of Electrical Installations in Hazardous Areas". Work on the electrical system or equipment must only be carried out by a skilled electrician himself or by specially instructed personnel under the control and supervision of such an electrician and in accordance with the applicable electrical engineering rules.
- For cable gland or conduit entries that are not used, user or installer shall close by certified blanking elements so that the flameproof properties of the enclosure are maintained.
- Flameproof enclosure, treat cover with care. Gap surfaces must not be damaged in any way. Do not jam cover during fitting.
- For testing purposes, loosen the bolts on the actuator cover and remove the cover.
- Make sure that the power supply voltage is in accordance with the data on the nameplate of the actuator.
- Pass cables through the cable glands: PF ¾", M20 or G¾" (EEX "d").
- Connect wires according to the enclosed wiring diagram (see Chapter 5.2)
- Manually move the valve to half-open position. Then electrically operate the actuator to fully open position and check if the motor rotates in correct direction, standard are counter-clockwise to open.
- Test the actuator and check whether the limit switches work correctly
- After the testing, check that all cable glands are correctly tightened. Applicable cable glands should be selected to meet the application's condition. It is recommended to use the grade of IP67 cable gland or higher in potentially explosive sites.
- Put back the cover and tighten the bolts.

## 5.2 WIRING DIAGRAMS FOR STANDARD MODELS

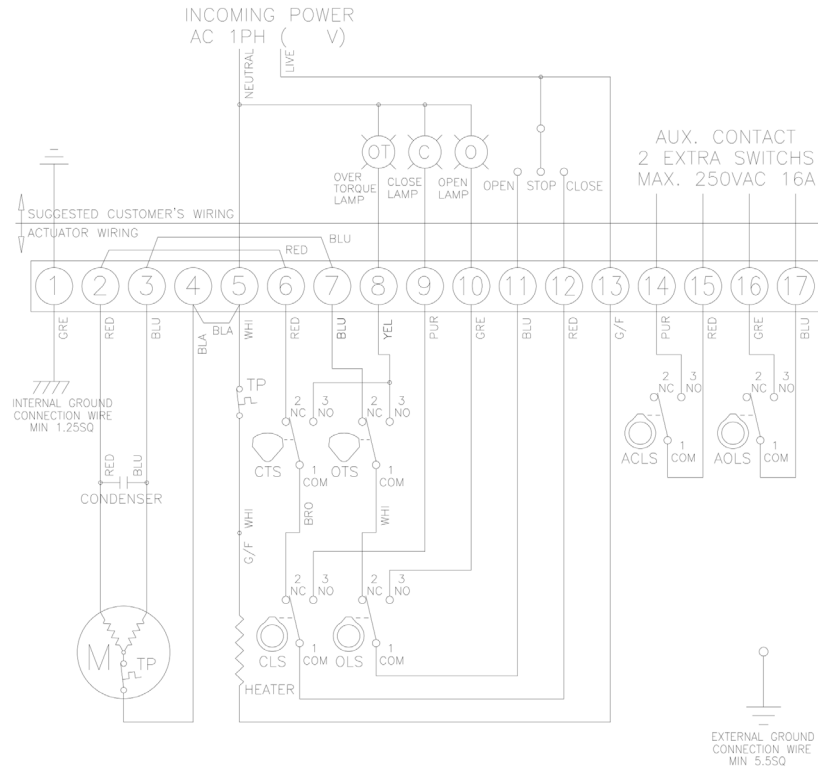

**⚠ DANGER: HAZARDOUS VOLTAGE.** No electrical power should be connected until all wiring and limit switch adjustments have been completed. Once the power is supplied to the unit, exercise caution when the cover is not installed.

NOTE: For more information, refer to Appendix II.

## 6.0 MAINTENANCE

### 6.1 MAINTENANCE

**⚠ CAUTION:** Turn off all power before attempting to perform maintenance on the actuator. **POTENTIALLY HIGH PRESSURE ITEM.** Before removing or disassembling your actuator, ensure that the valve or other actuated device is isolated and not under pressure.

Under the normal conditions, maintenance should be carried out at six month intervals. But when the conditions are more harsh, more frequent inspections may be advisable.

- Ensure that the actuator is properly aligned with the valve or other actuated device.
- Ensure that all wirings are insulated, connected properly.
- Ensure that all screws are present and tighten.
- Ensure cleanliness of internal electrical devices
- Ensure that conduit connections are properly installed and are dry.
- Check the internal devices for any condensation.
- Check the power to the internal heater.
- Check the enclosure of O-ring seals and verify that the O-rings are not pinched between flange.
- Verify the declutch mechanism.
- Visually inspect the open/close cycle.
- Inspect the identification labels for wear and replace it if necessary.

**⚠ WARNING:**

- Flameproof Enclosure! Before opening, ensure the absence of any gas and voltage
- Treat cover with care. Gap surfaces must not be damaged or dirtied in any way. Do not jam the cover during fitting.

### 6.2 TOOLS

- Metric Allen Key (Hex Wrench) × 1
- Screw Driver × 1
- Metric Spanner × 1
- Wrench 20mm × 1
- Wrench 30mm × 1
- Wire Stripper Long Nose × 1
- Multi-meter (AC, Dc, Resistance) × 1
- PCU Board Option: DC Signal Generator (4 – 20mA) × 1

## 7.0 TROUBLE SHOOTING

The following instructions are listed in the order of the most common difficulties encountered during the installation and start-up.

### The actuator does not respond

- Visually inspect the actuator to check no shipping or handling damage has occurred
- Verify the line voltage supplied to the actuator; check that the line voltage matches with the rating on the actuator's nameplate
- Check the internal wiring against the supplied wiring diagram of the actuator
- Check the limit switch cams

### The actuator is supplied with power but does not operate

- Verify the line voltage supplied to the actuator, check that the line voltage matches with the rating on the actuator's nameplate.
- Check that the actuator torque is greater than the valve torque
- Check the limit switch cams
- Check that the torque switches have not been tripped
- Check the mechanical travel stop adjustment
- Verify that the actuator against the rotation of the valve (standard are counter-clockwise rotation to open)
- Check for any corrosion and condensation that any of the electrical or mechanical devices have not been contaminated
- Verify that coupler/bracket is correctly installed and is not causing any binding

### Actuator runs erratically

- Check the ambient temperature
- Verify that the duty cycle has not been exceeded
- Check the position of manual override lever

### Optional Equipment(s)

#### 1) Potentiometer Current Position Transmitter

- Check the resistance value
- Check potentiometer gear for jamming
- Check ZERO and SPAN calibration
- Check the board for any damage

#### 2) Current Position Transmitter

- Verify the input signal
- Check the configuration of the DIP switches
- Check the board for any damage

## 8.0 INSTALLATION AND MAINTENANCE TIPS



CAUTION:

- 1) A regular inspection and maintenance should be performed by qualified and trained personnel
- 2) When working in potentially explosive areas, be sure to comply with the standard EN 60079-14 "Electrical Installations in hazardous Areas".
- 3) Working on the actuator that is in open position and under voltage must only be performed if it is assured that there is no danger of explosion for the duration of the work.
- 4) Pay attention to national regulations.

For any installation and maintenance work, the following should be noted:

- Check the quarter turn actuators visually. Ensure that no external damage or changes are visible. The electrical cables must not be damaged and wired correctly.
- Cable entries, cable glands, plugs, etc. have to be checked whether they are correctly tightened and sealed.
- Check that the Ex-connections are correctly fastened.
- Check for the possible discoloration of the terminals and wires as this may indicate an increased temperature.
- Check the flame path gaps of the flameproof enclosures for any dirt and corrosion. Since the dimensions of all Ex gaps are strictly defined and inspected, no mechanical work shall be performed on them.
- All cables and motor protection elements have to be checked.
- During the maintenance if any defects are detected that may affect the safety, repair measures have to be taken immediately.
- Any kind of surface coating for the gap surface is not permitted.
- When replacing parts, seals, etc., only original spare ones must be used.



WARNING:

- Flameproof Enclosure! Before opening, ensure the absence of any gas and voltage
- Treat cover with care. Gap surfaces must not be damaged or dirtied in any way. Do not jam the cover during fitting.

## APPENDIX I: 5630-Series Coding System (FOR CSA)

### ELECTRIC ACTUATOR ORDER CODING SYSTEM (Explosion Proof)

A	5630	
	SIZE	TORQUE
	008	80Nm
	010	100Nm
	015	150Nm
	020	200Nm
B	030	300Nm
	050	500Nm
	060	600Nm
	080	800Nm
	120	1200Nm
	200	2000Nm
	300	3000Nm
		ENCLOSURE
C	1	Weather proof (IP67)
	2	Submersible (IP68)
	3	Explosion Proof (Ex d IIB T4)
	VOLTAGE	
D	0	230V AC/1PH
	1	110V AC/1PH
	2	24V DC <sup>4)</sup>
	3	12V DC <sup>4)</sup>
	OPTION 1	
E	0	N/A
	1	PCU <sup>5)</sup>

A	B	C	D	E
5630	XXX	X	X	X

- NOTE:  <sup>4)</sup>5630-050 through 5630-300 actuators shall not be applied to the above condition.  
 <sup>5)</sup>5630-008 through 5630-010 actuators shall not be applied to the above condition.  
 More details should be advised to the manufacturer

## APPENDIX II: Wiring Diagram

5630-008/010 Standard 1Ph.

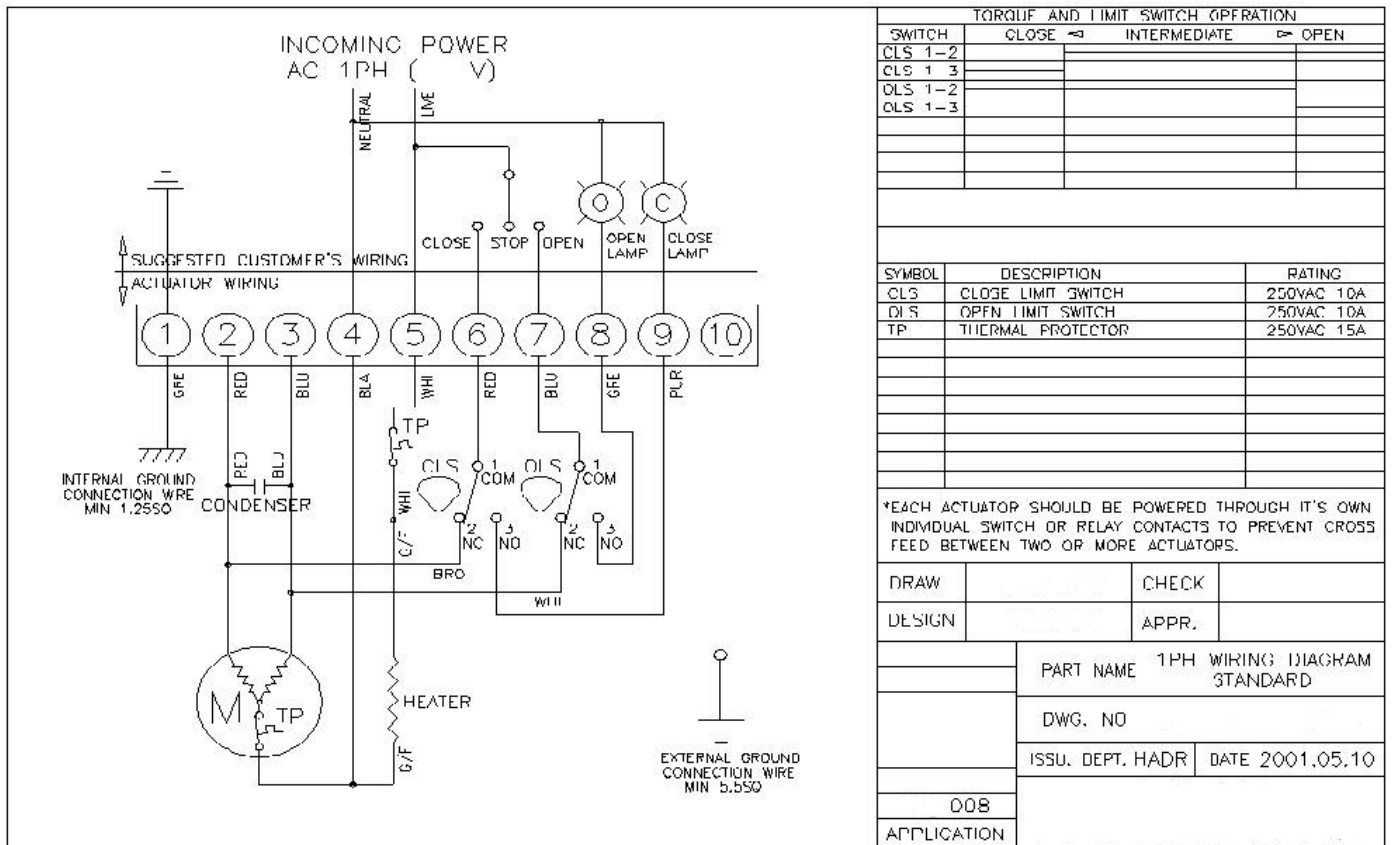

5630-008/010 Standard DC

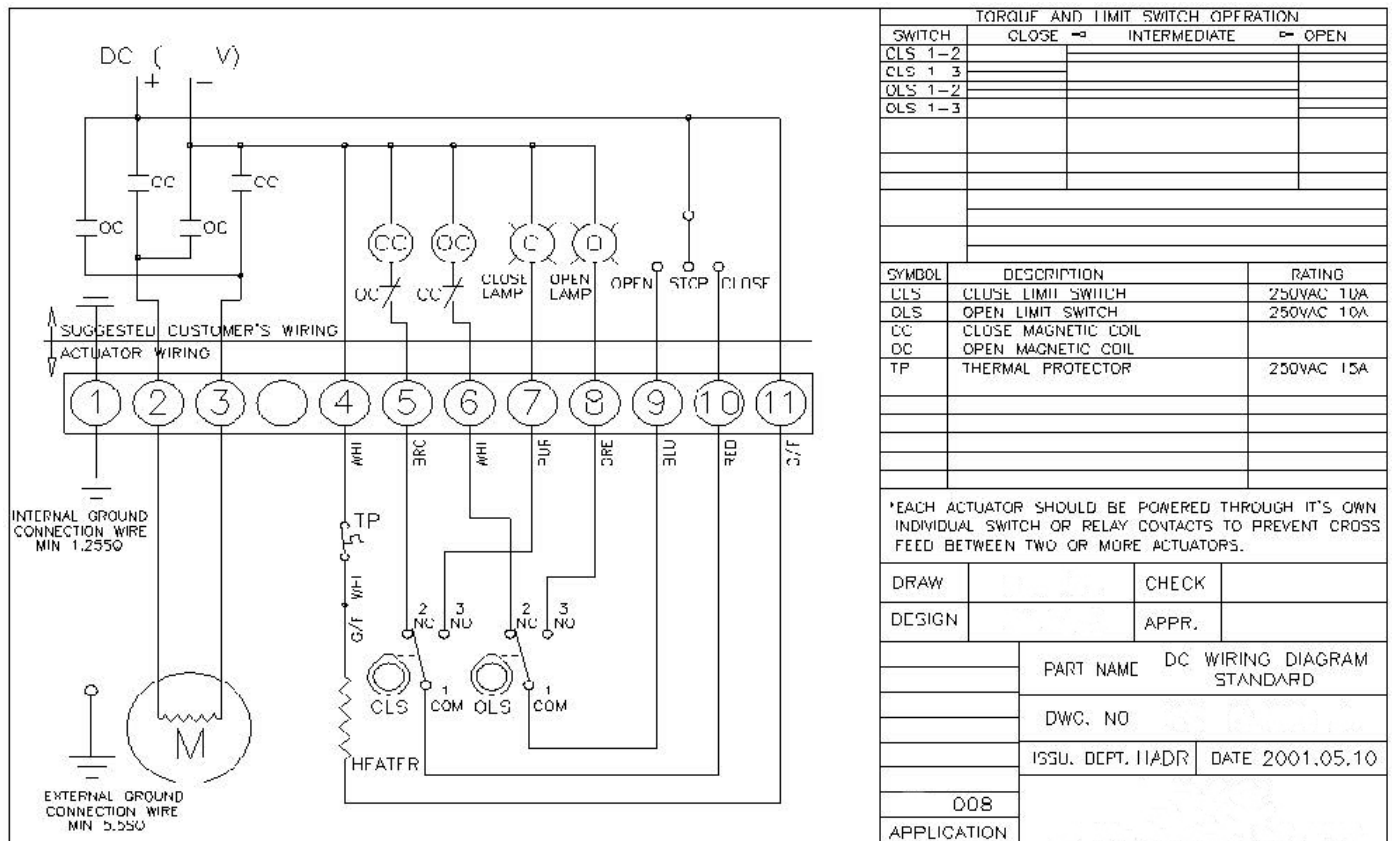

**DANGER: HAZARDOUS VOLTAGE.** No electrical power should be connected until all wiring and limit switch adjustments have been completed.

## APPENDIX II: Wiring Diagram

5630-015 ~ 300 Standard 1Ph.

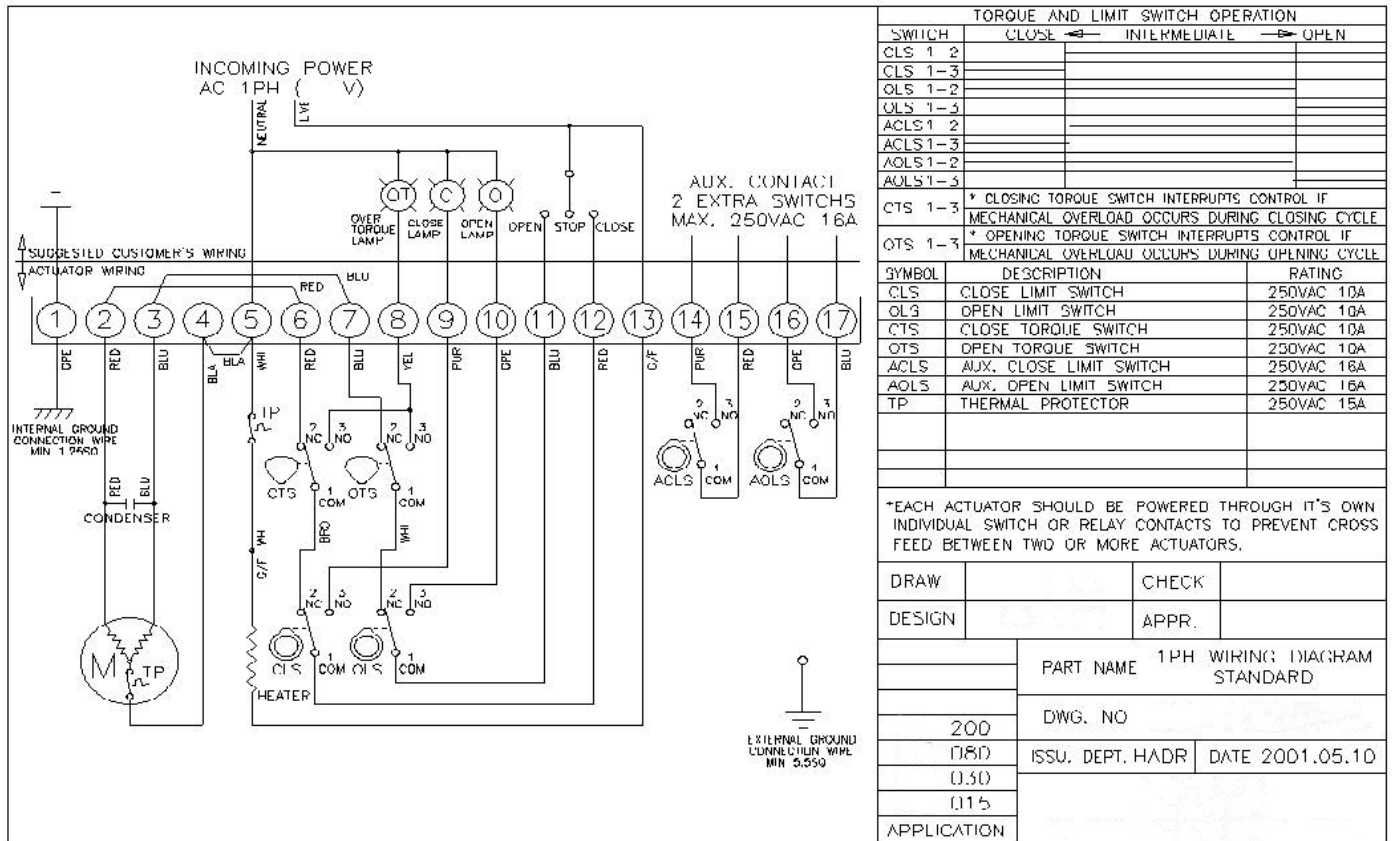

5630-015 ~ 300 Standard 1Ph. PCU

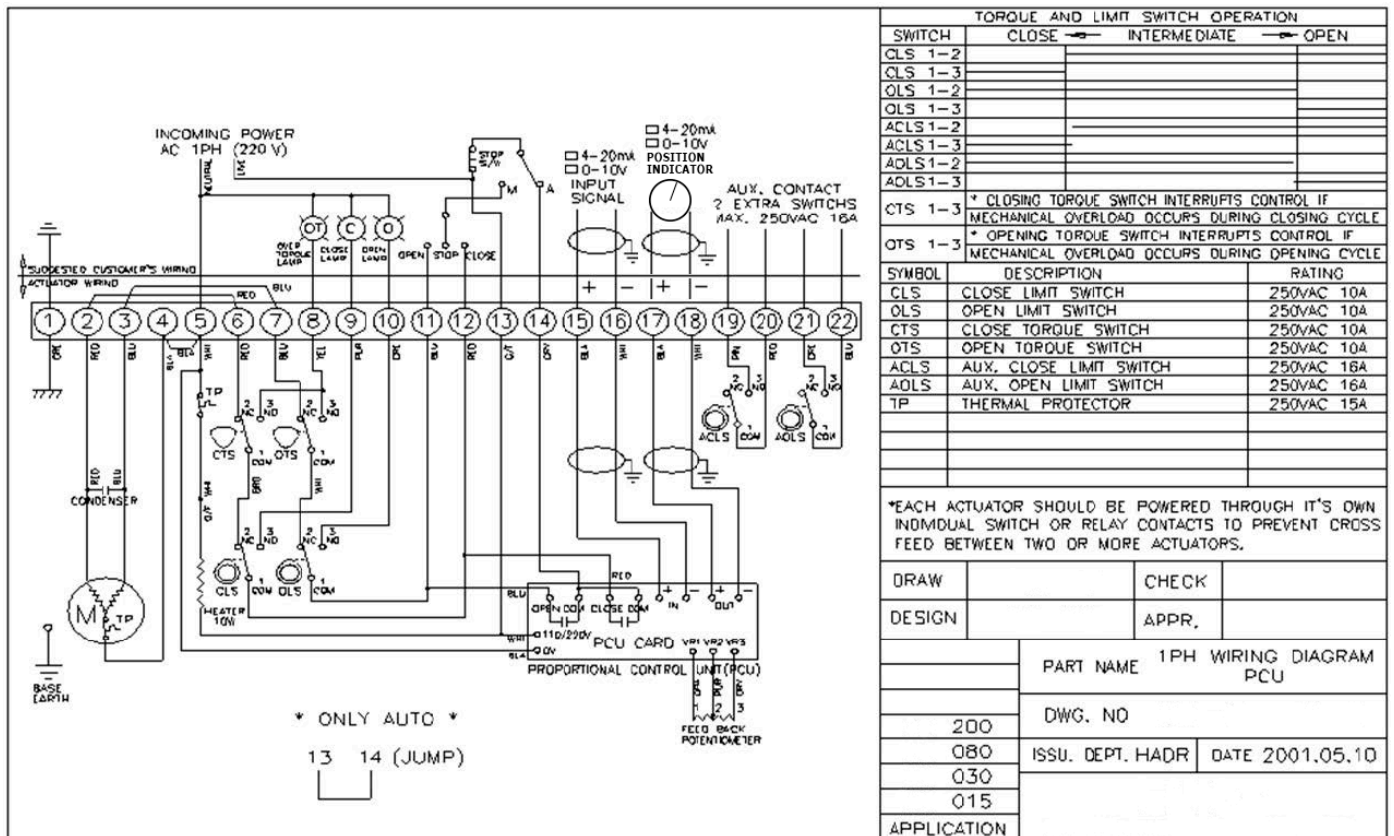

**⚠ DANGER: HAZARDOUS VOLTAGE.** No electrical power should be connected until all wiring and limit switch adjustments have been completed.



## APPENDIX II: Wiring Diagram

5630-015 ~ 300 Standard DC

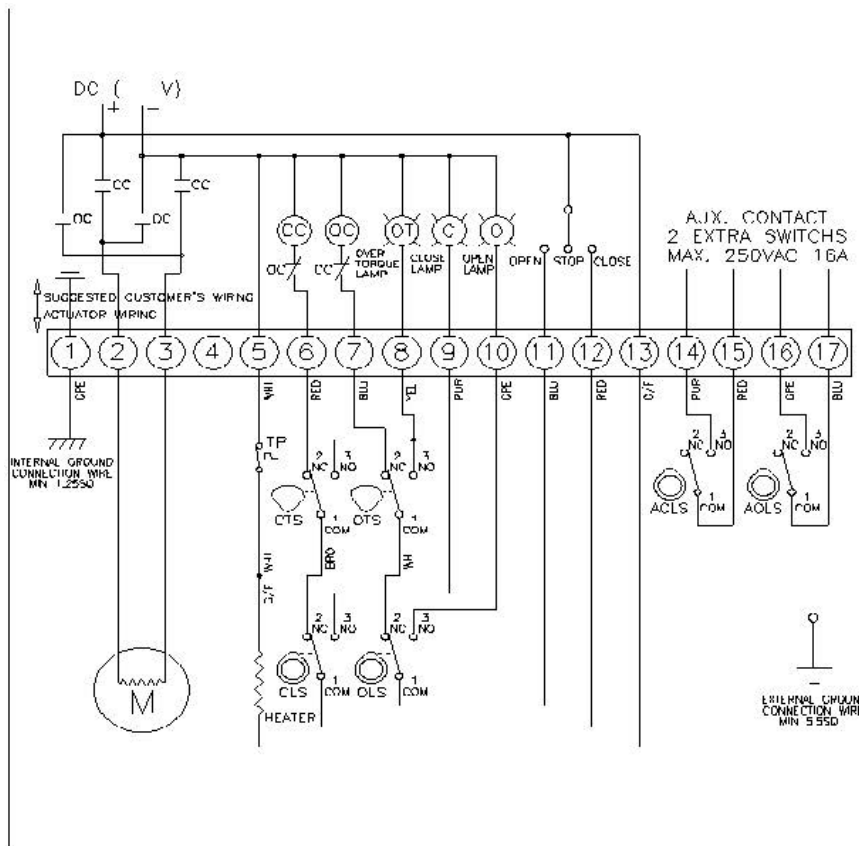

TORQUE AND LIMIT SWITCH OPERATION			
SWITCH	CLOSE ←	INTERMEDIATE	→ OPEN
CLS 1-2			
CLS 1-3			
OLS 1-2			
OLS 1-3			
ACLS1-2			
ACLS1-3			
AOLS1-2			
AOLS1-3			
CTS 1-3	* CLOSING TORQUE SWITCH INTERRUPTS CONTROL IF MECHANICAL OVERLOAD OCCURS DURING CLOSING CYCLE		
OTS 1-3	* OPENING TORQUE SWITCH INTERRUPTS CONTROL IF MECHANICAL OVERLOAD OCCURS DURING OPENING CYCLE		
SYMBOL	DESCRIPTION	RATING	
CLS	CLOSE LIMIT SWITCH	250VAC	10A
OLS	OPEN LIMIT SWITCH	250VAC	10A
CTS	CLOSE TORQUE SWITCH	250VAC	10A
OTS	OPEN TORQUE SWITCH	250VAC	10A
ACLS	AUX. CLOSE LIMIT SWITCH	250VAC	16A
AOLS	AUX. OPEN LIMIT SWITCH	250VAC	16A
CC	CLOSE MAGNETIC COIL		
OC	OPEN MAGNETIC COIL		
TP	THERMAL PROTECTOR	250VAC	15A

\*EACH ACTUATOR SHOULD BE POWERED THROUGH ITS OWN INDIVIDUAL SWITCH OR RELAY CONTACTS TO PREVENT CROSS FEED BETWEEN TWO OR MORE ACTUATORS.

DRAW		CHECK	
DESIGN		APPR.	
		PART NAME DC WIRING DIAGRAM STANDARD	
		DWG. NO	
D.30		ISSU. DEPT. HADR	
D.15		DATE 2001.05.10	
APPLICATION			

5630-015 ~ 300 Standard DC PCU

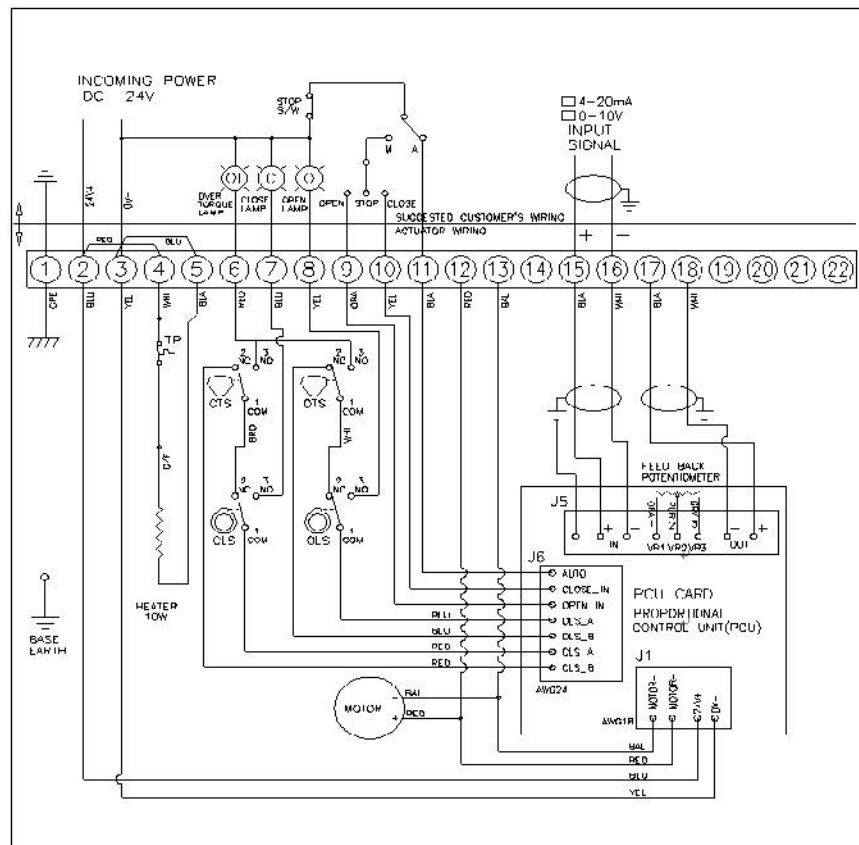

TORQUE AND LIMIT SWITCH OPERATION			
SWITCH	CLOSE ←	INTERMEDIATE	→ OPEN
CLS 1-2			
CLS 1-3			
OLS 1-2			
OLS 1-3			
ACLS1-2			
ACLS1-3			
AOLS1-2			
AOLS1-3			
CTS 1-3	* CLOSING TORQUE SWITCH INTERRUPTS CONTROL IF MECHANICAL OVERLOAD OCCURS DURING CLOSING CYCLE		
OTS 1-3	* OPENING TORQUE SWITCH INTERRUPTS CONTROL IF MECHANICAL OVERLOAD OCCURS DURING OPENING CYCLE		
SYMBOL	DESCRIPTION	RATING	
CLS	CLOSE LIMIT SWITCH	250VAC	10A
OLS	OPEN LIMIT SWITCH	250VAC	10A
CTS	CLOSE TORQUE SWITCH	250VAC	10A
OTS	OPEN TORQUE SWITCH	250VAC	10A
ACLS	AUX. CLOSE LIMIT SWITCH	250VAC	16A
AOLS	AUX. OPEN LIMIT SWITCH	250VAC	16A
TP	THERMAL PROTECTOR	250VAC	15A

\*EACH ACTUATOR SHOULD BE POWERED THROUGH ITS OWN INDIVIDUAL SWITCH OR RELAY CONTACTS TO PREVENT CROSS FEED BETWEEN TWO OR MORE ACTUATORS.

DRAW		CHECK	
DESIGN		APPR.	
		PART NAME DC WIRING DIAGRAM PCU	
		DWG. NO	
D.30		ISSU. DEPT. HADR	
D.20		DATE 2011.01.10	
D.15			
APPLICATION			

DANGER: HAZARDOUS VOLTAGE. No electrical power should be connected until all wiring and limit switch adjustments have been completed.

## APPENDIX III: Grounding

5630-008/010 Grounding

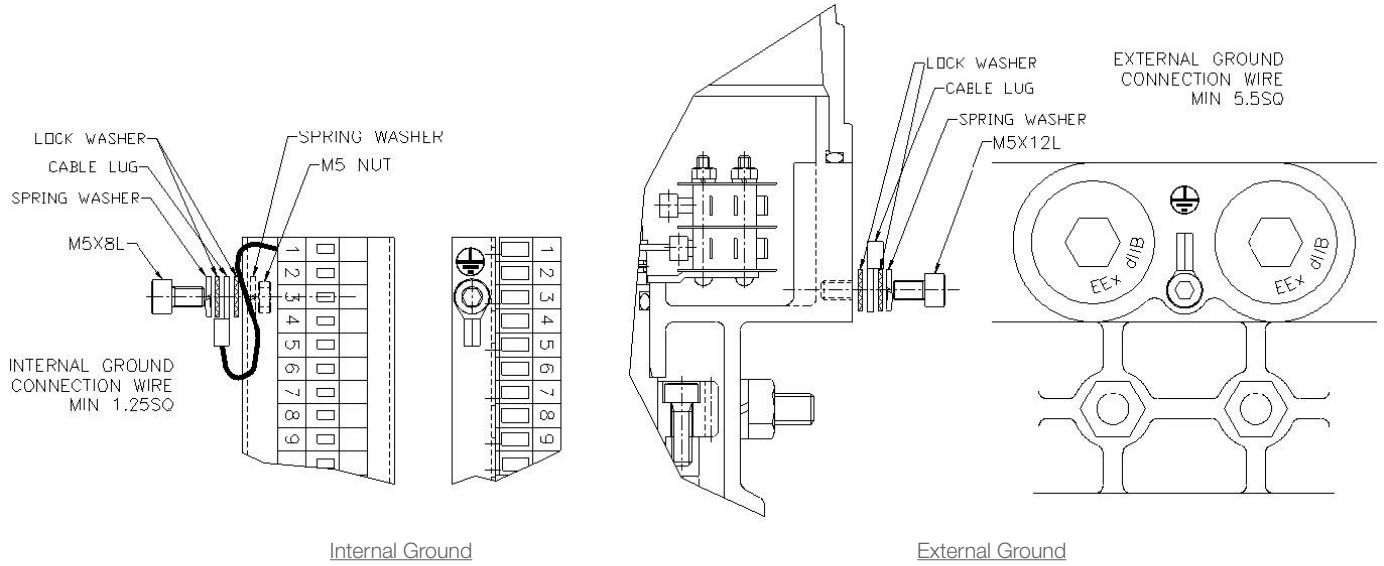

Terminal Block 1, should be used for internal grond.

**DANGER:** Flameproof Enclosure! Before opening, ensure that there is no explosive gas or voltage..

## APPENDIX III: Grounding

HQ-015 ~ 300 Grounding

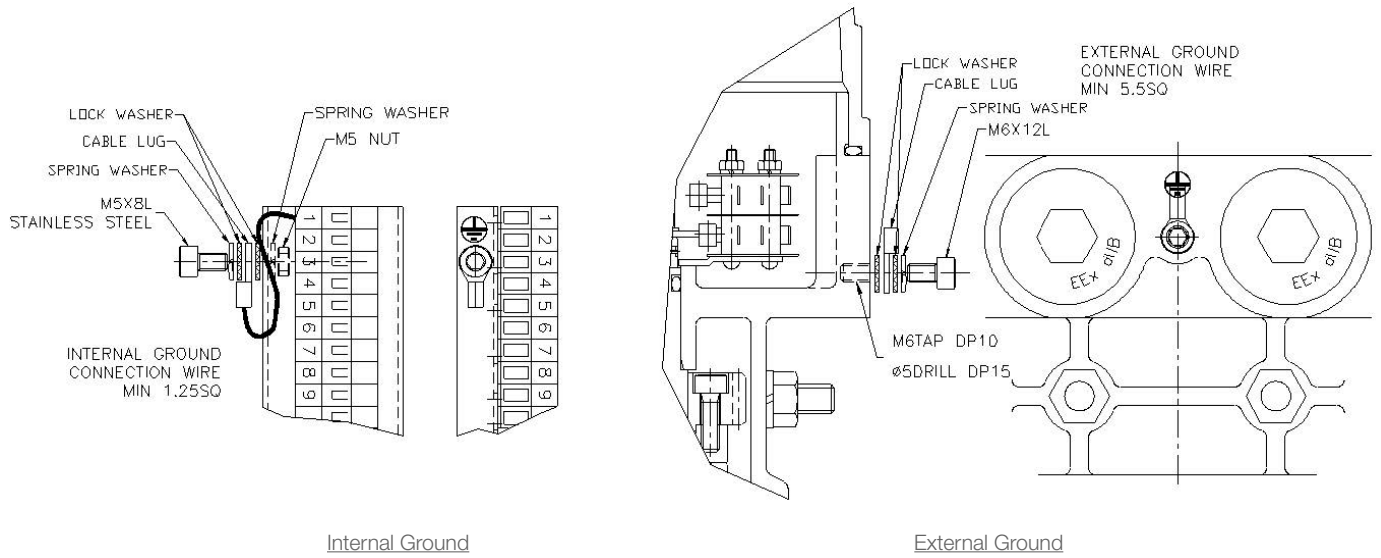

Terminal Block 1, should be used for internal grond.

**DANGER:** Flameproof Enclosure! Before opening, ensure that there is no explosive gas or voltage.



## Know-how makes the difference

Dansk Ventil Center A/S

### Product Range

- ❑ Ball valves
- ❑ Butterfly valves - Soft seated
- ❑ Butterfly valves - Metal seated
- ❑ Angle seat valves
- ❑ Thin wafer check valves
- ❑ Safety valves
- ❑ Knife gate valves
- ❑ Pneumatic actuators
- ❑ Electrical actuators
- ❑ Brackets for actuators
- ❑ Limit switches
- ❑ Level gauges - Reflex & transparent
- ❑ Control valves
- ❑ Pressure reducing valves

Dansk Ventil Center is committed to meeting the needs of customers in an environmentally sound and sustainable manner, through continuous improvements in environmental performance in all our activities.

Dansk Ventil Center is located in the northern part of Europe, in the heart of Denmark.

Visit us at [www.dvc.nu](http://www.dvc.nu) and learn more about Dansk Ventil Center and our products.



Dansk Ventil Center A/S  
Ferrarivej 14  
DK-7100 Vejle  
Denmark

Tel.: +45 75 72 33 00  
Fax: +45 75 72 75 15  
E-mail: [mail@dvcas.dk](mailto:mail@dvcas.dk)  
Web: [www.dvc.nu](http://www.dvc.nu)

