



TYPE 6140/-1

Thin Wafer Check Valve





APPLICATION AND OPERATIONS

The **DVC type 6140/6141 Thin Wafer Check Valve** is a self-operating check valve designed to prevent the backflow of gas or liquid media. Initial opening of the **DVC type 6140/6141 Thin Wafer Check Valve** disc begins when the upstream pressure exceeds the downstream pressure and the effective torque of the spring. This pressure is called the "cracking" pressure. Once the **DVC type 6140/6141 Thin Wafer Check Valve** disc open, flow velocity determines the position and stability of the discs.

If the flow velocity upstream of the **DVC type 6140/6141 Thin Wafer Check Valve** decreases and/or stops, the gravity and/or spring force the discs to a closed position. Ideally, the disc will be fully closed just prior to flow reversal, thus alleviating the potential for water hammer.

Warning: Non-return swing check valves cannot be used as on/off valves nor as safety valves
Warning: **DVC type 6140/6141 Thin Wafer Check Valve** cannot be used for application with unstable fluids.

HANDLING AND LIFTING INSTRUCTIONS

WARNING! DO NOT LIFT THE VALVE BY THE DISC STOP, HINGE SHAFT, DISC, OR BY ANY OTHER MEANS NOT UTILIZING THE LIFTING EYE BOLT.

This can damage the valve and become very dangerous, when handling. Care should be taken such as not to drop the valve or cause damage to the valve flange or any exterior special coating. Large and heavy valves are furnished with lifting eye bolts for easy handling and lifting. For safe handling and lifting it is suggested that the item be lifted only by the eye bolt, when either being installed or removed.

RECEIVING INSTRUCTIONS

Unloading should be carried out in a careful manner. Upon receipt the **DVC type 6140/6141 Thin Wafer Check Valve** should be inspected prior to installation. Valve flange faces should be inspected for possible damage during shipment and any special coatings should be checked for nicks, scrapes, scratches or other types of damage they may have occurred during shipment.

DVC type 6140/6141 Thin Wafer Check Valve is furnished with nameplates which identify general information about the particular valve. Nameplate information can be documented at time of receipt at the discretion of the customer.

STORAGE INSTRUCTIONS

To minimize damage or deterioration of the **DVC type 6140/6141 Thin Wafer Check Valve** supplied, it is suggested that the **DVC type 6140/6141 Thin Wafer Check Valve** be stored indoors. If the **DVC type 6140/6141 Thin Wafer Check Valve** is stored in a dry indoor location it will not be necessary to cover the valve. A thin coat of easily removable rust preventative should be applied to all machined areas, including metal seating surfaces of the valve body and disc. Should outside storage be required, it is suggested that the **DVC type 6140/6141 Thin Wafer Check Valve** be packaged (similar to packaging for export shipment) so as to prevent environmental damage to the valve. Note that valve body and disc seating surfaces should receive the most attention.



INSTALLATION INSTRUCTIONS

Installation must be done only between flanges.

Check that the flow's direction is the same as the one indicated by an arrow on the valve's label. (see Fig. 1)

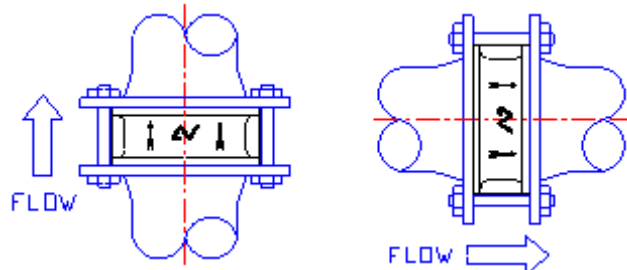

Fig. 1

In the horizontal piping, please install the valve vertically according to Fig. 2.

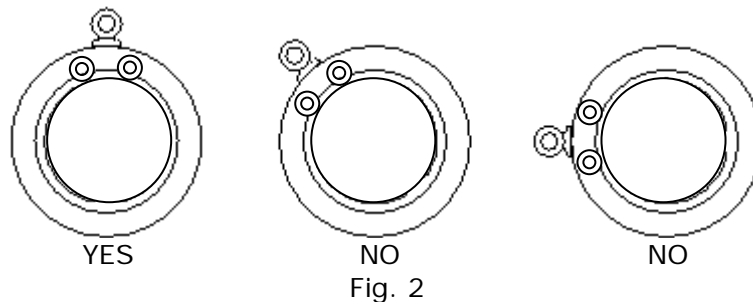

Fig. 2

MAINTENANCE INSTRUCTIONS

The **DVC type 6140/6141 Thin Wafer Check Valve** is maintenance free, meaning it needs no periodic lubrication, packing adjustment or seat adjustment. The valve should be inspected every (one) year in order to check for wear of the discs, spring, shafts and body.

The torque on the flange studs nuts should be checked periodically to insure no loosening has occurred due to pipe vibration, thermal cycling and stretching of the stud.

Routine maintenance of all types consists of the following operations:

- 1) Replacement of the o-rings. This operation is recommended at least once every year.
- 2) Replacement of the discs, of the screws and the washers. This operation must be done every 36 months at least.

Warning: The above mentioned terms are highly reduced in case of high aggressiveness of the fluid or in case of turbulence.

LIMITATIONS AND PRECAUTIONS



DVC type 6140/6141 Thin Wafer Check Valve valves are not recommended for the following service conditions.

- Pulsating Flows
- Installation directly to a Butterfly valve or other piping accessory that may interfere with the opening or closing of **DVC type 6140/6141 Thin Wafer Check Valve** discs.
- Vertical Flow DOWN without prior Factory Approval

The following precautions should be taken to insure long service life of **DVC type 6140/6141 Thin Wafer Check Valve** valves.

- Accurate sizing of **DVC type 6140/6141 Thin Wafer Check Valve** is crucial to ensure an acceptable pressure drop and long service life.
- Flow velocities should be in the recommended range.
- A minimum of 5 (five) pipe diameters should be maintained between the **DVC type 6140/6141 Thin Wafer Check Valve** and likely causes of turbulence. (i.e. pump discharge, reducers, elbows and tees, etc.)

FAILURE TO CLOSE

DVC type 6140/6141 Thin Wafer Check Valve is a general purpose swing check valve designed to prevent back flow. This design has been installed and operates successfully in both liquid and gas applications.

It is important to understand that the **DVC type 6140/6141 Thin Wafer Check Valve** is a swing check valve that has a modified and improved design. The cause of swing check valve failure, excluding warranted defects in material and workmanship, is usually, too low or high liquid velocities and turbulence or corrosion.

The discs position and movement is determined by the flow. Therefore, it is very important to size the valve correctly. Should the flow velocity be too low, less than 6 ft/sec the discs will not be in a stable position and will "flutter". Disc flutter causes the discs to wear excessively and also causes the spring (if spring version) to cycle excessively and fail prematurely. Excessive velocities (11 t/sec, liquid; f 250 ft/sec gas) will also cause the discs to flutter and wear out the spring.

Turbulent flows caused by pump discharges, elbows or similar upstream of a check valve will also cause the discs to flutter excessively. It is recommended that all check valves be installed a minimum 5 pipe diameters downstream from sources of turbulence.