

3-PCS CRYOGENIC BALL VALVE

TYPE 1380



GENERAL

DIMENSION/PRESSURE:	DN10 - DN40: PN130 DN50: PN100
MATERIAL:	ACID-PROOF STAINLESS STEEL
CONNECTION:	BUTT WELD SCH. 40
FACE-TO-FACE:	DIN3202 M3 S13
MOUNTING FLANGES:	ISO 5211
TEMPERATURE RANGE:	-196° C TO +150° C
OPERATION:	HANDLE

OPTIONS

DIMENSION:	DN8
CONNECTION:	FLANGED, SOCKET WELD, THREAD "BSP"
OPERATION:	PNEUMATIC ACTUATOR OR ELECTRICAL ACTUATOR

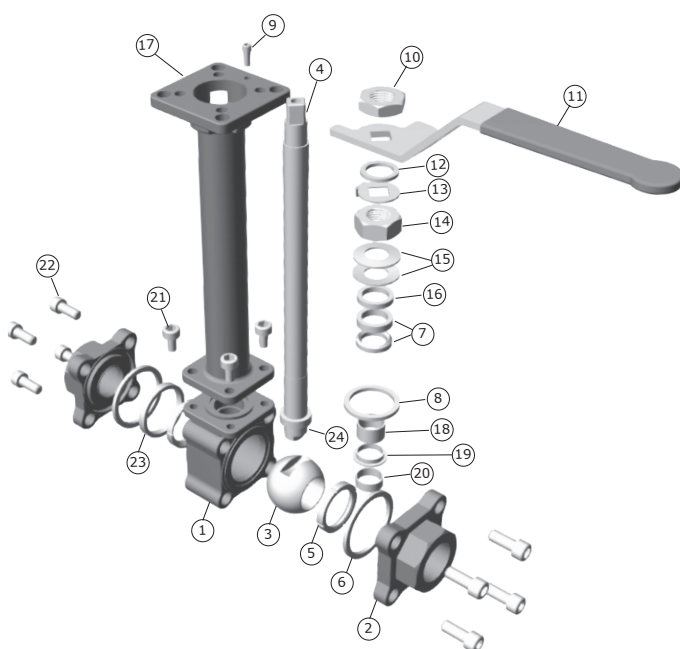

POS	DESCRIPTION	MATERIAL
1	BODY	CF8M
2	END CAP	CF3M / CF8M (THREAD)
3	BALL	CF8M
4	STEM	17- 4 PH SS
5	SEAT	PCTFE (KEL-F)
6	BODY SEAL	GRAFOIL
7	PACKING	TFM4215
8	EXTENSION GASKET	GRAFOIL
9	HANDLE NUT	AISI 304
10	HANDLE	AISI 304
11	HANDLE	AISI 304
12	GLAND 1	AISI 304
13	LOCK WASHER	AISI 304
14	GLAND NUT	AISI 304
15	BELLEVILLE WASHER	AISI 301
16	GLAND 2	AISI 316
17	EXTENSION BONNET	CF8M
18	LINER 1	50% STAINLESS STEEL + 50% PTFE
19	L-LINER	50% STAINLESS STEEL + 50% PTFE
20	LINER 2	50% STAINLESS STEEL + 50% PTFE
21	EXTENSION BOLT	AISI 316
22	BOLT	AISI 316
23	SEAT RETAINER	AISI 316
24	ANTI STATIC DEVICE	AISI 304

DESCRIPTION

- **3-pcs cryo ball valve with temperature span from -196°C to +150°C.** Suitable for nitrogen, CO₂, oxygen, etc. All valves are degreased for oxygen.
- **Long neck prevents freezing of the stem packing** as this is located at the top of the stem extension. This minimizes the risk of leakage.
- **All balls are drilled with a relief hole** to prevent thermal expansion.
- **Material certifikat EN10204/3.1** is available.

SUITABLE FOR



INDUSTRY



MARINE



COOLING SYSTEM

DIMENSIONS

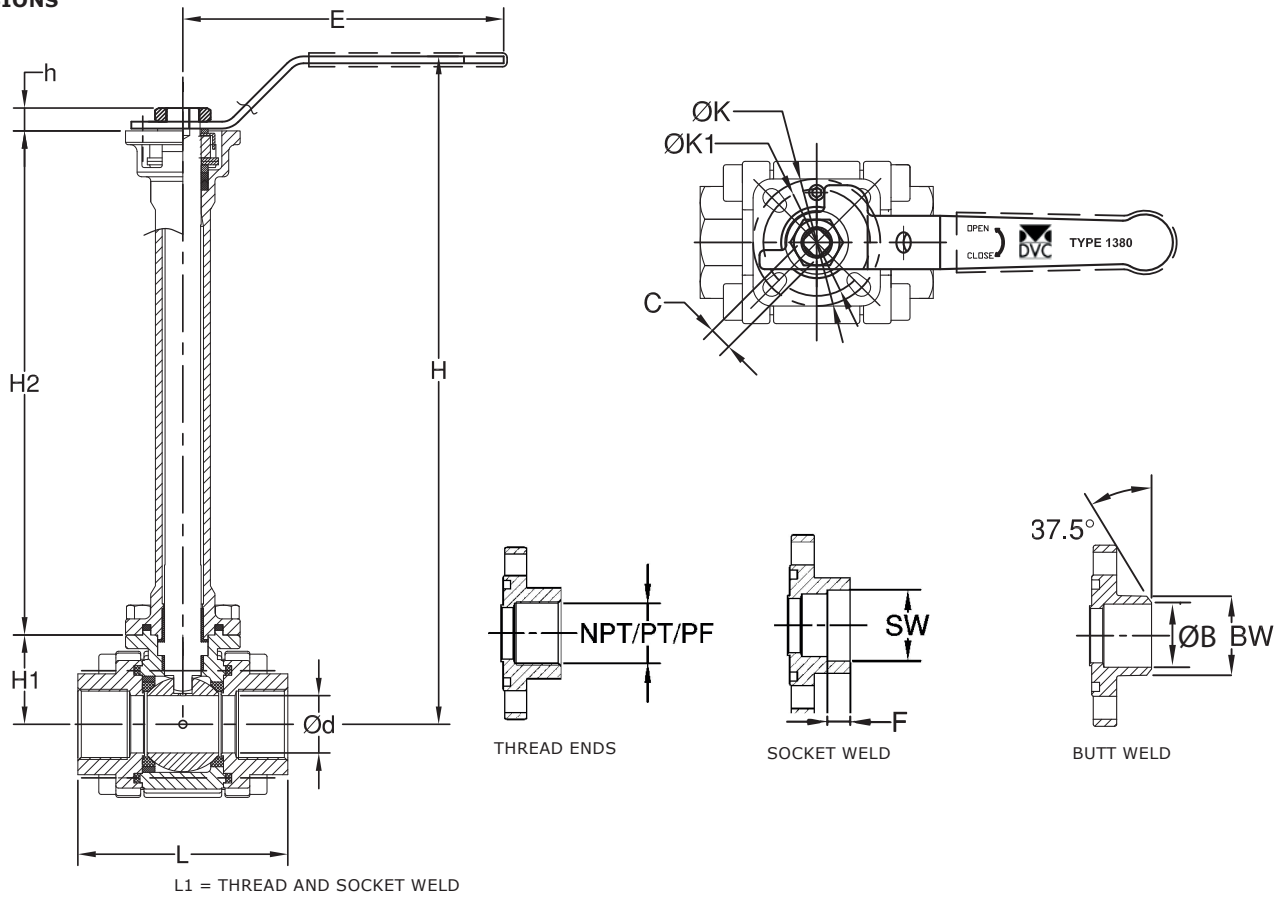

DIM	DIM	ØOD [MM]	L [MM]	L1 [MM]	E [MM]	H [MM]	H1 [MM]	H2 [MM]	h [MM]	C [MM]	ØK [MM]	ØK1 [MM]	SW [MM]	F [MM]	ØB [MM]	BW [MM]	KV [NM ³ /T]	TORQUE [NM]		WEIGHT [KG]
																		20°C	-196°C	
DN10	3/8	9.6	67	67	156	274.0	39.0	200	8.0	9	F05	F04	17.8	-	13.7	17.2	6.9	14.0	31.0	1.7
DN15	1/2	15.0	75	75	156	274.0	39.0	200	8.0	9	F05	F04	21.8	13	15.8	21.4	16.4	22.1	36.8	1.7
DN20	3/4	20.0	90	80	156	276.0	42.6	200	8.0	9	F05	F04	27.2	13	20.9	26.7	30.3	26.4	44.1	2.2
DN25	1	25.0	100	90	181	287.0	47.2	200	10.0	11	F07	F05	33.8	15	26.6	33.4	43.3	29.4	58.8	2.8
DN32	1 1/4	31.0	110	110	181	292.0	51.2	200	10.0	11	F07	F05	42.7	15	35.0	42.2	95.2	41.1	82.3	3.8
DN40	1 1/2	38.0	125	120	395	403.0	58.5	300	13.0	14	F10	F07	48.8	16	40.8	48.3	173.0	51.5	102.8	6.9
DN50	2	50.0	150	140	395	423.0	76.2	300	13.0	14	F10	F07	61.2	17	52.5	60.5	302.8	73.5	235.0	9.5

Torque figures includes 30% safety factor.

PRESSURE/TEMPERATURE

