

DESCRIPTION

Solenoid valve 2 way normally open with servo-assisted diaphragm

CONSTRUCTION

Body and cover	Brass
Armature tube	AISI 303
Plunger and core	AISI 430FR
Springs	AISI 302
Seal material	NBR - FPM - EPDM



FEATURES

- Minimum differential pressure 0.15bar
- Maximum allowable pressure PS 25bar^④
- Maximum fluid viscosity 25cSt (mm²/s)
- Ambient temperature: from -10°C to +80°C according to the coil
- Preferred mounting position with vertical coil above

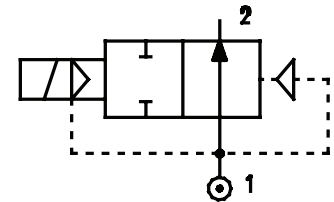

4

- OPTIONS:** Electroless nickel plating
 Series 7 explosion proof coil according to ATEX - EExmII
 us certified coils

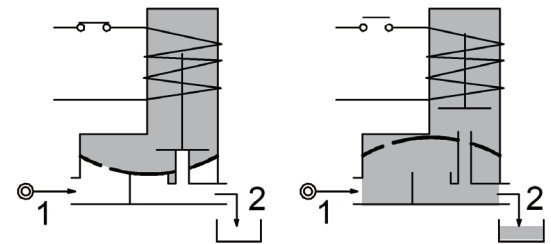

ON REQUEST: Manual override

CODE ① ②	Connection G ISO 228	Orifice mm	Kv m ³ /h	Differential pressure bar			Nominal power			Coil		Seal ①	Temp. range °C
				Min	Max		AC Inrush	VA Holding	DC Watt	Series	Width		
E207B...10///...	1/4"	10	1.5	0.15	15	15	12	8	6.5	3	22	NBR=B EPDM=E FPM=V	-10 +90 -10 +140 -10 +140
E207C...10///...	3/8"	10	1.7	0.15	15	15							
E207C...12///...	3/8"	12	2.2	0.15	15	15							
E207D...12///...	1/2"	12	2.5	0.15	15	15							
E207E...18///...	3/4"	18	5.5	0.15	13	13							
E207F...25///...	1"	25	10.2	0.15	10	10							
E207G...30///...	1" 1/4	30	15	0.15	10	10							
③E207C...12/WI...	3/8"	12	2.2	0.5	15	15	12	8	6.5	3	22	NBR=B	-10 +90
③E207D...12/WI...	1/2"	12	2.5	0.5	15	15							

- ① Seal
 - ② Coil
 - ③ Reinforced diaphragm
 - ④ The maximum allowable pressure PS for steam 2,5bar (gauge pressure)
- Example: E207DB12///301 NBR seal
 Coil 24V DC

COILS ②	Alternating Current 50/60Hz (V)							Direct Current (V)			Electrical connection	Connectors
	12	24	48	110	220 230	240	380	12	24	48		
Series 3 Width 22	30A	30B	30C	30D	30E	30F	30G	300	301	302	DIN 46244	PG9 code 10348000

DESCRIPTION
 Class F insulation
 Voltage tolerance
 AC +15% -10%
 DC ± 10%
 Protection class
 IP65 with connector fitted
 IP00 without connector
 Continuous service ED100%

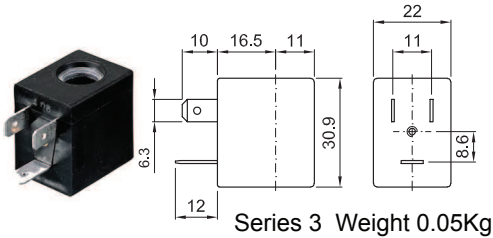

OPTIONS
 Class H insulation
 Cable attached
 Special coil voltage
 Special coil powers
 cULus certified coils

(for coil details see section 8)

SPARE PARTS LIST

1. Coil fixing nut
2. Coil
3. Seal assembly
4. Armature tube with core
5. Diaphragm assembly

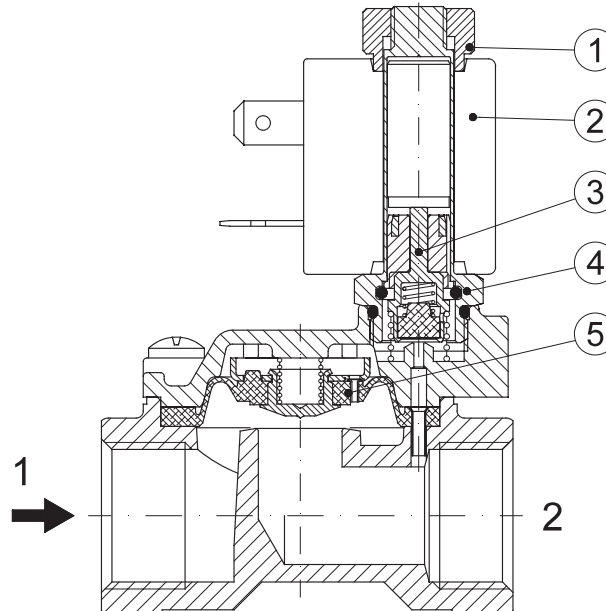

OVERALL DIMENSION

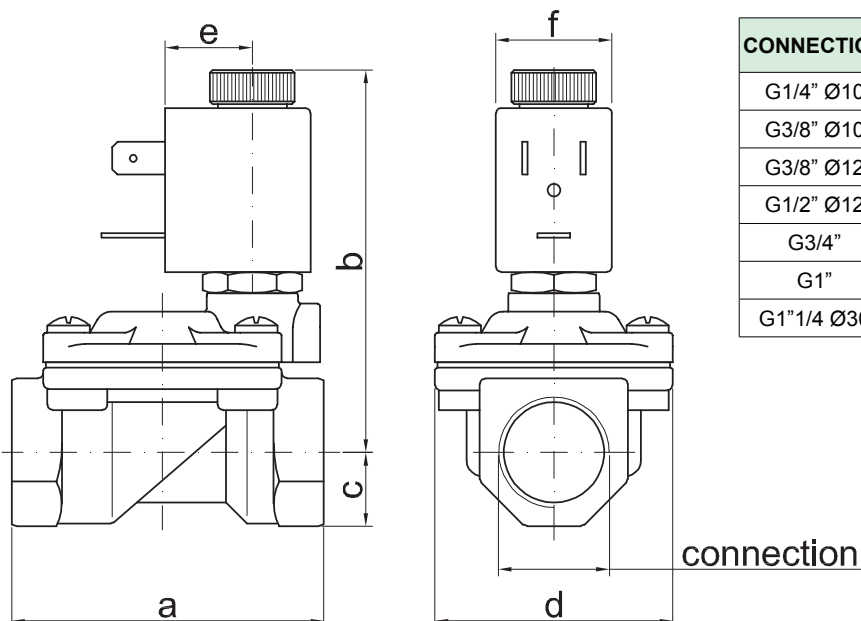

CONNECTION	a	b	c	d	e	f	weight Kg
G1/4" Ø10	49	65	11	32	16	22	0.23
G3/8" Ø10	49	65	11	32	16	22	0.24
G3/8" Ø12	59	73	14	45	16	22	0.42
G1/2" Ø12	59	73	14	45	16	22	0.39
G3/4"	79	76	18	55	16	22	0.65
G1"	96	85	20	72	16	22	1.05
G1"1/4 Ø30	119	96	25	85	16	22	1.70

DESCRIPTION

Solenoid valve 2 way normally open with servo-assisted diaphragm

CONSTRUCTION

Body and cover	Brass
Armature tube	Brass
Plunger and core	AISI 430FR
Springs	AISI 302
Seal material	NBR - FPM - EPDM



FEATURES

Minimum differential pressure 0.15÷3bar
 Maximum allowable pressure PS 20bar^④
 Maximum fluid viscosity 25cSt (mm²/s)
 Ambient temperature: from -10°C to +80°C according to the coil
 Preferred mounting position with vertical coil above

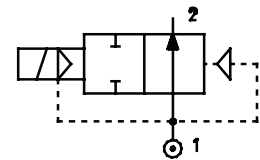

4

OPTIONS: Electroless nickel plating
 c us certified coils

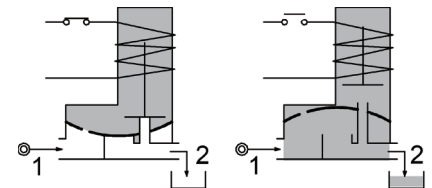

ON REQUEST: Manual override

CODE ① ②	Connection G ISO 228	Orifice mm	Kv m ³ /h	Differential pressure bar			Nominal power			Coil		Seal ①	Temp. range °C
				Min	Max		AC Inrush	VA Holding	DC Watt	Series	Width		
					AC	DC							
E207G...37///...	1"1/4	37	18	0.15	10	10	20	15	10	2	30	NBR=B EPDM=E FPM=V	-10 +90 -10 +140 -10 +140
E207H...37///...	1"1/2	37	21	0.15	10	10							
E207I...50///...	2"	50	36	0.15	10	10							
E207MB75///...	2"1/2	75	75	0.3	5	5	20	15	10	2	30	NBR=B	-10 +90
E207RB75///...	3"	75	84	0.3	5	5							
③E207MB75/W/...	2"1/2	75	75	3	15	15	40	30	27	5	36		
③E207RB75/W/...	3"	75	84	3	15	15							

① Seal
 ② Coil
 ③ Reinforced diaphragm
 Example: E207HB37///201 NBR seal
 Coil 24V DC

④ **REMARK**
 The maximum allowable pressure PS for steam 2,5bar (gauge pressure)

G2"1/2 e G3" SOLENOID VALVES

For applications with fluids listed in chapter 3 / group 1 of the PED Directive 2014/68 / EU (potentially hazardous or explosive fluids / mixtures) consider a PS value reduced to 15 bar max.

COILS ②	Alternating Current 50/60Hz (V)							Direct Current (V)			Electrical connection	Connectors
	12	24	48	110	220 230	240	380	12	24	48		
Series 2 Width 30	20A	20B	20C	20D	20E	20F	20G	200	201	202	DIN 43650A	PG9 code 10349000
Series 5 Width 36	52A	52B	52C	52D	52E	52F	52G	520	521	522	DIN 43650A	PG11 code 10349001

DESCRIPTION
 Insulation class
 Series 2 =F Series 5=H
 Voltage tolerance
 AC +15% -10%
 DC ± 10%
 Protection class
 IP65 with connector fitted
 IP00 without connector

OPTIONS
 Class H insulation (series 2)
 Cable attached
 Special coil voltage
 Special coil powers
 c US certified coils

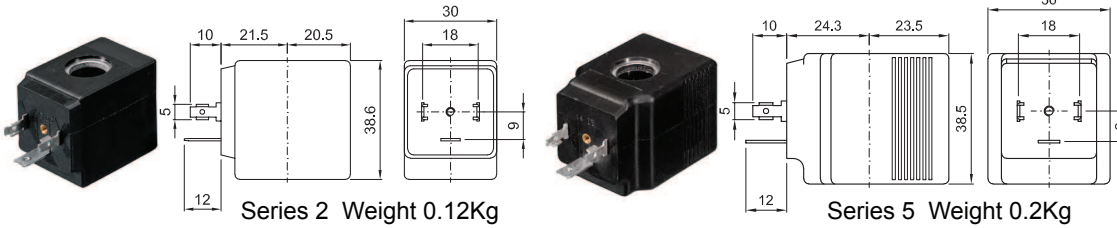

(for coil details see section 8)

SPARE PARTS LIST

1. Coil fixing nut
2. Coil
3. Seal assembly
4. Armature tube with core
5. Diaphragm assembly
6. Speed control valve
7. Water hammering reducer
 $\varnothing 0.8$ - $\varnothing 1.2$ - $\varnothing 1.5$ (G2"1/2-3")

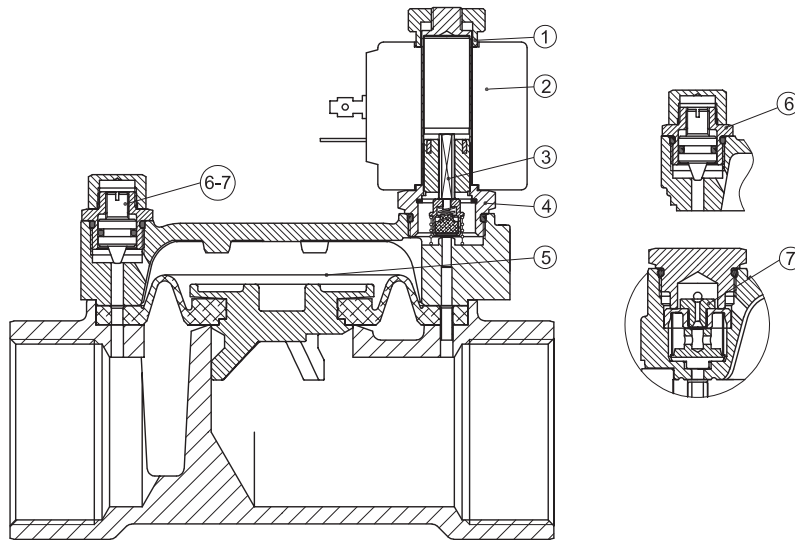

OVERALL DIMENSION

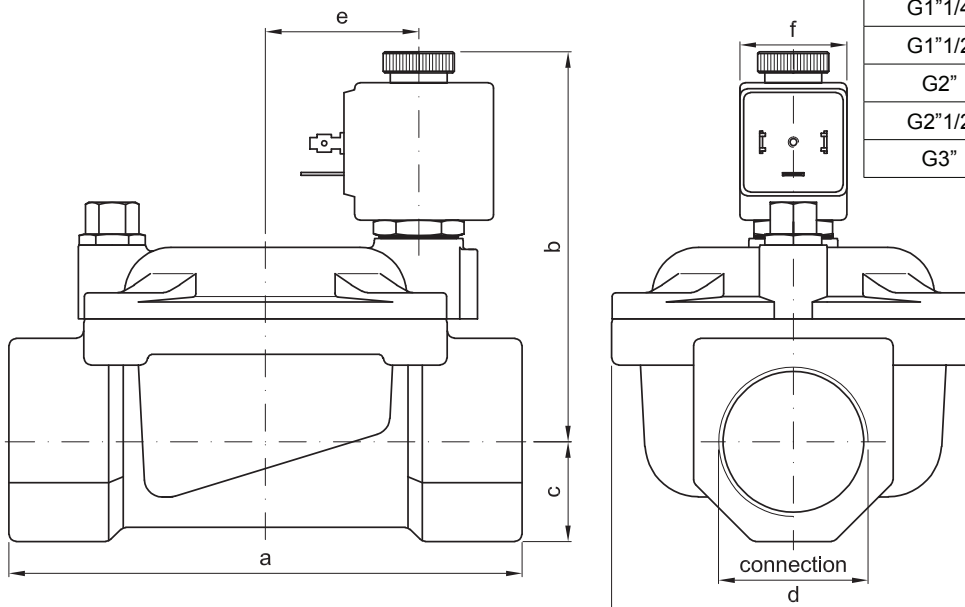

CONNECTION	a	b	c	d	e	f	weight Kg
G1"1/4	142	105	28	102	21	30	3.00
G1"1/2	142	105	28	102	21	30	2.85
G2"	158	119	35	119	21	30	4.30
G2"1/2	226	135	51	169	21	30	11.7
G3"	226	135	51	169	21	30	9.9