

BUTTERFLY VALVE TYPE WAFER

TYPE E6330 - FOOD APPROVED



econ®

GENERAL

DIMENSION/PRESSURE:	DN50 - DN150 = PN16 DN200 - DN600 = PN10
TEMPERATURE:	-10°C TO +140°C (PRESSURE AND TEMPERATURE ARE INTERDEPENDENT)
MATERIAL LINER:	ERIKS EPDM FOOD (EC1935)
SURFACE:	2-LAYER EPOXY, RAL 5015
FACE TO FACE:	EN558-1 SERIES 20
OPERATION:	FREE STEM
COUNTER FLANGES:	DN50 - DN300 = PN6/10/16/ANSI150 DN350 - DN600 = PN10/16/ANSI150
TOP FLANGE:	ISO 5211

OPTION

LINER:	FPM (NOT FOOD APPROVED)
OPERATION:	HANDLE, GEAR, ACTUATOR (PNEUMATIC/ELECTRIC)

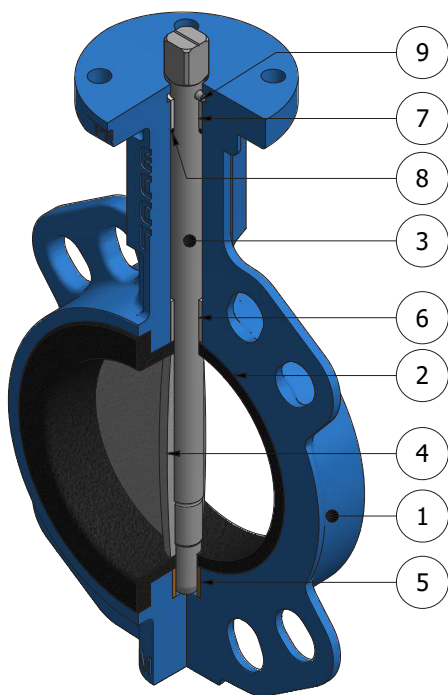

POS	DESCRIPTION	MATERIAL
1	BODY	DUCTILE IRON EN-GJS-400-15
2	LINER	ERIKS EPDM FOOD GRADE
3	STEM	STAINLESS STEEL AISI 410
4	DISC	STAINLESS STEEL 1.4408/CF8M
5	LOWER STEM BEARING	BRONZE
6	UPPER STEM BEARING	RPTFE + STAINLESS STEEL
7	BUSHING	DELTRIN
8	O-RING	NBR
9	PIN	STAINLESS STEEL

DESCRIPTION

- High quality industrial butterfly valve **suitable for contact with food stuff** according to European Directive 1935/2004/EC and American FDA regulation.
- **Peroxide hardened rubber** liner as opposed to the commonly used sulphur hardened rubber, provides a soft liner even at low temperatures. Therefore the valve is ideal for waterworks, as opposed to other valve types which tend to get stuck.
- **Splines** connection between stem and disc for better grip and less play.
- **ISO 5211 top flange** and 90° square stem enables direct mounting of actuator without the use of bracket and coupling.
- **Approvals:** FDA 21 CFR 177.2600, EC1935:2004
- **Self-centering flanges** according to DIN PN6/10/16 and ANSI150.
- Optional mounted with **gear or handle, or pneumatic or electric actuator** for easy operation.

DS-E6330-UK-10-2022-REV. D
We reserve the right for changes.

DIMENSIONS

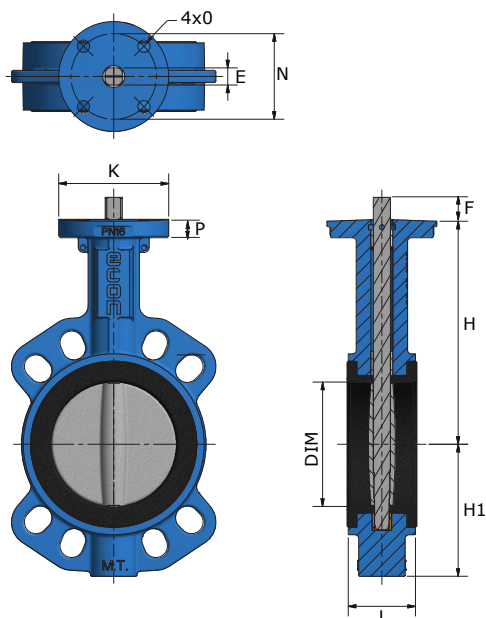

DIM	DIMENSIONS										
	[MM]	H [MM]	H1 [MM]	L [MM]	K [MM]	P [MM]	F [MM]	E [MM]	O [MM]	N [MM]	ISO
DN50	143	80	43	65	13.5	14	11	6.5	50	F05	3.0
DN65	155	90	46	65	13.5	15	14	6.5	50	F05	4.0
DN80	162	115	46	90	13.5	15	14	6.5 / 9.0	50/70	F05/F07	4.0
DN100	181	125	52	90	13.5	19	14	9.0	70	F07	5.5
DN125	197	135	56	90	13.5	19	17	9.0	70	F07	7.3
DN150	210	140	56	125	17.0	19	17	11.0	102	F10	8.2
DN200	240	185	60	125	17.0	28	22	11.0	102	F10	13.5
DN250	286	210	68	150	17.0	28	22	11.0 / 13.0	102/125	F10/F12	21.2
DN300	309	245	78	150	19.5	30	27	13.0	125	F12	32.5
DN350	329	303	78	175	21.0	30	27	14.0 / 18.0	125/140	F12/F14	48.0
DN400	361	335	102	210	21.0	30	27	18.0 / 22.0	140/165	F14/F16	60.0
DN450	393	363	114	210	21.5	38	36	18.0 / 22.0	140/165	F14/F16	80.0
DN500	427	397	127	210	21.5	38	36	18.0 / 22.0	140/165	F14/F16	125.0
DN600	492	459	154	210	22.0	49	46	22.0	165	F16	200.0

VALVE DATA

DIM	MAX. TORQUE	KV-VALUE (M ³ /H 1 BAR ΔP)								
		10°	20°	30°	40°	50°	60°	70°	80°	90°
[MM]	[NM]									
DN50	25	1,1	3,8	10,2	22	38	60	100	132	193
DN65	29	2	7,5	18,2	35	61	95	187	240	315
DN80	45	2,5	9,8	26	48	83	126	214	338	425
DN100	59	3,8	14,6	39	72	119	221	361	606	723
DN125	99	6,5	24	62	118	217	394	599	1038	1243
DN150	182	10	41	95	175	326	542	873	1260	1859
DN200	275	19	64	165	306	573	995	1567	2310	3124
DN250	442	28	101	245	451	836	1462	2253	3256	4757
DN300	661	34	129	312	615	1137	2125	3248	4991	7058
DN350	874	47	163	390	795	1489	2573	3980	5749	8319
DN400	1169	62	231	508	1077	1973	3381	5385	8099	11458
DN450	1464	75	256	621	1208	2315	3925	6331	9474	13612
DN500	1822	103	346	859	1692	3086	5348	8513	13109	18748
DN600	2127	139	494	1153	2389	4466	7561	11945	18088	25217

TORQUE FIGURES INCLUDE 30% SAFETY FACTOR

PRESSURE/TEMPERATURE

SIZE	LINER	TEMPERATURE [°C]	MAX. OPERATION PRESSURE [BAR]
DN50 - DN150	EPDM FOOD	-10°C TO 140°C	16
DN200 - DN600	EPDM FOOD	-10°C TO 140°C	10
DN50 - DN150	FPM	-10°C TO 204°C	16
DN200 - DN600	FPM	-10°C TO 204°C	10

PRESSURE AND TEMPERATURE ARE INTERDEPENDENT.



Temperature/Pressure

Butterfly valves from Dansk Ventil Center A/S is delivered with different pressure levels and with different liner types. Always check the name plate to ensure correct operation. Pressure systems with flanges according to EN1092-1 has some limitations. Be careful not to exceed the allowable pressure/temperature limits, as this may cause damage to personal or equipment.

Rubber seat (NBR, EPDM and FPM):

Rubber will over time lose flexibility and compression set. The higher the temperature rubber is installed in, the shorter the expected lifespan is.

Our values for temperature is given to the best of our knowledge, and we advise that valves are tested for lifespan if installation is running near the given temperature limit. If in doubt, please consult us.