

WAFER BALL VALVE

TYPE E7383



econ®

GENEREL

DIMENSION/PRESSURE: DN15 - DN50 = PN40
DN65 - DN150 = PN16

TEMPERATURE: -30°C TO 200°C
(PRESSURE AND TEMPERATURE ARE INTERDEPENDENT)

FLANGES: EN 1092-1
MATERIAL: ACID-PROOF STAINLESS STEEL
TOP FLANGE: ISO 5211
BALL SURFACE HARDENING: 300HV

OPTION

BALL SURFACE HARDENING: 1200HV +/-100HV

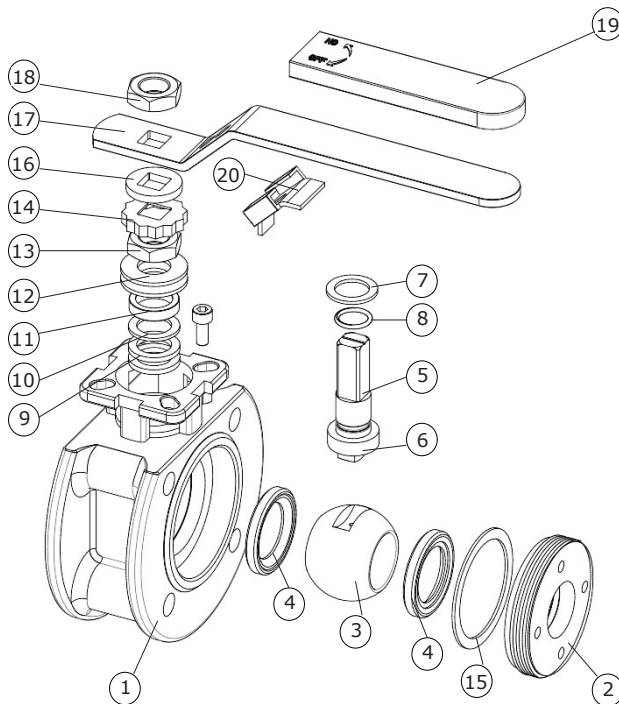

POS	DESCRIPTION	MATERIAL
1	BODY	STAINLESS STEEL CF8M
2	END CAP	STAINLESS STEEL CF8M
3	BALL	STAINLESS STEEL CF8M
4	BALL SEATS	PTFE (TFM 1600)
5	STEM	STAINLESS STEEL AISI 316
6	ANTI-STATIC DEVICE	STAINLESS STEEL AISI 316
7	THRUST WASHER	PTFE
8	O-RING	FPM
9	STEM PACKING	PTFE
10	PACKING	50% STAINLESS STEEL + PTFE
11	GLAND	STAINLESS STEEL AISI 316
12	BELLEVILLE WASHERS	STAINLESS STEEL AISI 301
13	STEM NUT	STAINLESS STEEL AISI 304
14	STOP-LOCK CAP	STAINLESS STEEL AISI 304
15	BODY GASKET	PTFE
16	STEM WASHER	STAINLESS STEEL AISI 304
17	HANDLE	STAINLESS STEEL AISI 304
18	NUT	STAINLESS STEEL AISI 304
19	HANDLE SLEEVE	PVC
20	LOCKING DEVICE	STAINLESS STEEL AISI 304

DESCRIPTION

- **Solid full bore ball valve** with short face-to-face dimension. For mounting between flanges.
- **Inspection window** for control of the open/close function and the seal ring when actuator is installed directly onto the valve.
- **Maintenance free stuffing box** with belleville spring washers, V-rings and O-ring, providing optimum sealing capabilities - even at changing temperatures.
- **Wax cast ball valve** in acid-proof stainless steel. The wax cast provides for an easy cleanable surface structure.
- **Integrated ISO 5211 top flange** and square stem making it quick and easy to install actuators without the use of brackets and couplings. This compact unit is inexpensive and gives fewer transitions = less slack.
- **Full bore** resulting in no pressure loss through the ball valve.
- **Increased surface hardness of the ball** can be opted for extremely abrasive media to be more resistant to wear and thus extend the lifespan of the ball.
- **Material certificate** 3.1/EN10204 on all valves. Fire safe design (not certified), EN 12266 class A, TA-luft, suitable for Atex area (Group II, equipment category 2).
Food approvals: FDA, EC1935

DS-E7383-UK-01-2020-REV. B
We reserve the right for changes.

DIMENSIONS

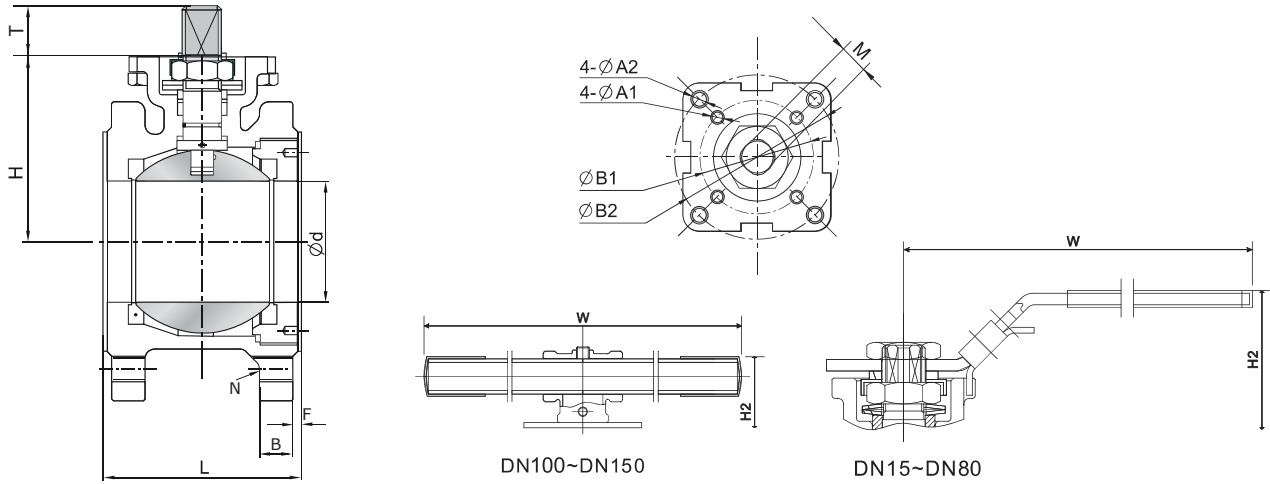

DIM [MM]	VALVE WITH HANDLE								ISO TOP FLANGE				STEM			
	Ød	L	H	H2	W	N	B	F	ØB1	ØB2	ØA1	ØA2	ISO	M	T	
	[MM]														5211	[MM]
DN15	15.0	42	49	77	145	4xM12	9	2	36	42	4x6	4x6	F03/F04	9	9	
DN20	20.0	44	55	82	145	4xM12	9	2	36	42	4x6	4x6	F04/F05	9	9	
DN25	25.0	50	62	94	175	4xM12	9	2	42	50	4x6	4x7	F04/F05	11	11	
DN32	32.0	60	72	104	175	4xM16	12	2	42	50	4x6	4x7	F04/F05	11	11	
DN40	38.0	65	78	114	194	4xM16	13	3	50	70	4x7	4x9	F05/F07	14	14	
DN50	50.0	80	86	120	194	4xM16	20	3	50	70	4x7	4x9	F05/F07	14	14	
DN65	63.5	110	108	158	265	4xM16	18	3	70	102	4x9	4x11	F07/F10	17	17	
DN80	76.0	120	116	165	265	8xM16	20	3	70	102	4x9	4x11	F07/F10	17	17	
DN100	95.0	150	139	182	400	8xM16	20	3	-	102	-	4x11	F10	22	22	
DN125	118.0	180	176	224	600	8xM16	22	3	-	125	-	4x14	F12	27	27	
DN150	142.0	225	192	268	800	8xM20	22	3	-	125	-	4x14	F12	27	27	

DIM [MM]	TORQUE * [NM]		Kv-VALUE [M ³ /H AT 1 BAR]		WEIGHT	
	BREAK AWAY TORQUE		90° FULLY OPEN		[KG]	
DN15	6.5		15		1.4	
DN20	7.8		31		1.8	
DN25	14.3		41		2.4	
DN32	22.1		80		3.9	
DN40	29.9		141		4.9	
DN50	44.2		177		8.6	
DN65	68.9		386		10.1	
DN80	113.1		668		14.5	
DN100	170.3		1165		22.7	
DN125	353.6		1458		50.0	
DN150	715.0		2228		70.0	

* Torque figures include 30% safety factor. (TEST: 0bar diff. pressure, ambient temperature, non-lubricating).

PRESSURE / TEMPERATURE

