

3-PCS BALL VALVE - FULL BORE

TYPE E7424 (THREAD) & E7624 (WELD): STEEL
TYPE E7444 (THREAD) & E7621 (WELD): STAINLESS STEEL



econ[®]

GENERAL

DIMENSION:	1/4" - 2" FB (STEEL) DN15 - DN100 (STAINLESS STEEL)
PRESSURE:	68 BAR / 1000 PSI WOG (E7424, E7624, E7444)
PRESSURE:	25 BAR / 400 PSI WOG (E7621)
TEMPERATUR:	-29°C TO 204°C (STEEL) -34°C TO 204°C (STAINLESS STEEL)
(PRESSURE AND TEMPERATURE ARE INTERDEPENDENT)	
ISO TOP FLANGE:	ISO 5211
THREAD ENDS:	BSPP
BUTT WELD ENDS:	SCH. 40 (STEEL) ISO 1127 (STAINLESS STEEL)

OPTION

SIZE:	2½" - 4" (E7424, E7444)
-------	-------------------------

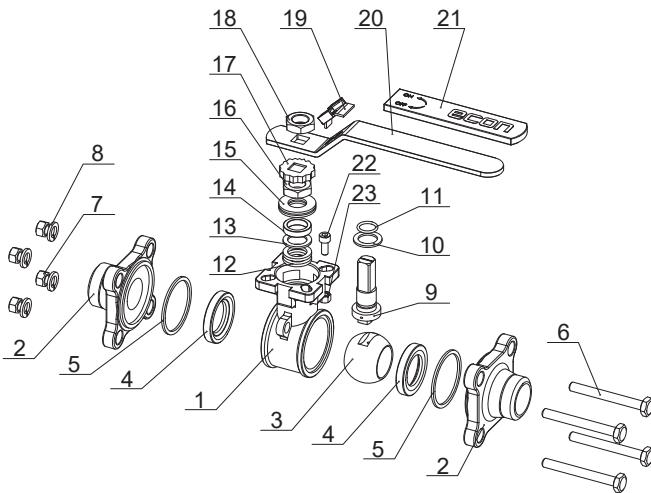

POS	DESCRIPTION	STEEL	STAINLESS
1	BODY	WCB	CF8M
2	CAP	WCB	CF8M
3	BALL		CF8M
4	SEAT		PTFE
5	JOINT GASKET		PTFE
6	BOLT	AISI 304	
7	NUT	AISI 304	
8	BOLT WASHER	AISI 304	
9	STEM	AISI 316	
10	THRUST WASHER		PTFE
11	O-RING		FPM
12	STEM PACKING		PTFE
13	BUSHING	50% SS + 50% PTFE	
14	GLAND	AISI 316	
15	BELLEVILLE WASHER	AISI 301	
16	STEM NUT	AISI 304	
17	STOP LOCK CAP	AISI 304	
18	NUT	AISI 304	
19	LOCKING DEVICE	AISI 304	
20	HANDLE	AISI 304	
21	HANDLE SLEEVE		PVC PLASTIC
22	STOP BOLT	AISI 304	
23	STOP NUT	AISI 304	

DESCRIPTION

- **Solid industrial ball valve** in acid-proof, stainless steel CF8M and steel WCB. The 3-pcs. design with "build-in flanges" makes it easy to remove the valves middle part for maintenance.
- **Maintenance free stuffing box** with spring washers, PTFE V-rings and FPM O-ring provides optimum sealing and longer service life. The stuffing box will self-adjust under changing temperatures and due to wear.
- **The Blow-out proof stem**, has apart from a security function also the benefit of increasing the stem sealing when pressure rises.
- **Electric equalizer connections**, between ball, stem and body makes it possible to install this valve type in ATEX area (Group II, equipment category 2).
- **Traceability on all ball valves**, and delivery of material certificate EN 10204/3.1 on request.
- **ISO 5211 top flange** makes it simple and easy to mount an actuator without bracket and coupling. A compact solution with less connections = less slack.
- **Stainless steel weld ends ISO 1127**, and steel weld ends Sch. 40 are standard. Furthermore thread ends in BSPP.

DS-E7424-E7444-E7624-E7621-UK-02-2022-REV. B
We reserve the right for changes.

DIMENSIONS

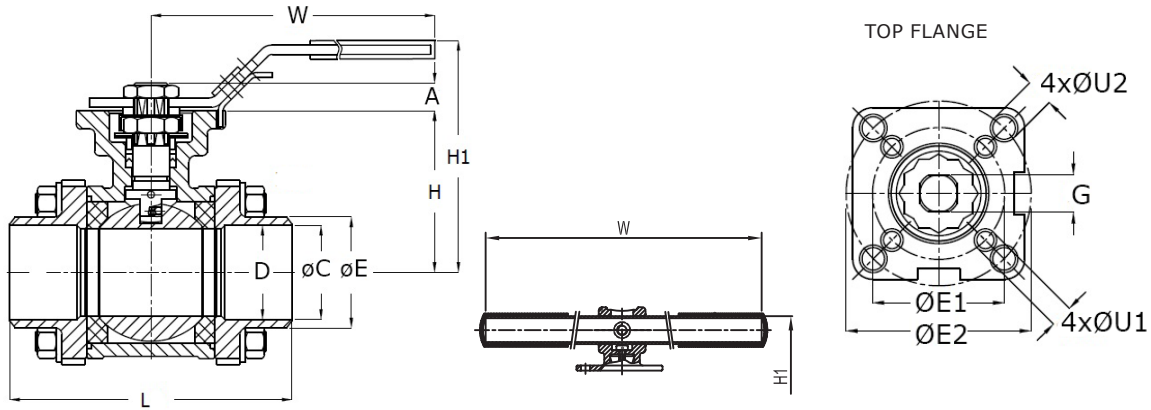

DIMENSION		VALVE WITH HANDLE					ISO TOP FLANGE					STEM	
[MM]	[INCH]	L [MM]		H	H1	W	øE1	øE2	4xøU1	4xøU2	ISO 5211	G	A
		THREAD	BW	[MM]	[MM]	[MM]	[MM]	[MM]	[MM]	[MM]		[MM]	[MM]
DN08	1/4"	75.0	70.0	42.5	72.0	147.0	36	42	6	6	F03/F04	9	9.0
DN10	3/8"	75.0	70.0	42.5	72.0	147.0	36	42	6	6	F03/F04	9	9.0
DN15	1/2"	75.0	75.0	42.5	72.0	147.0	36	42	6	6	F03/F04	9	9.0
DN20	3/4"	80.0	90.0	49.0	80.0	147.0	36	50	6	7	F03/F05	9	9.0
DN25	1"	90.0	100.0	59.0	90.0	177.0	42	50	6	7	F04/F05	11	11.0
DN32	1 1/4"	110.0	110.0	63.0	95.0	177.0	42	70	6	9	F04/F07	11	11.0
DN40	1 1/2"	120.0	125.0	71.3	106.0	197.0	50	70	7	9	F05/F07	14	14.0
DN50	2"	140.0	150.0	78.2	113.0	197.0	50	70	7	9	F05/F07	14	14.0
DN65	2 1/2"	185.5	190.0	100.0	150.0	295.0	70	102	9	11	F07/F10	17	17.0
DN80	3"	205.0	220.0	109.0	159.0	295.0	70	102	9	11	F07/F10	17	17.0
DN100	4"	240.0	270.0	140.0	212.0	400.0	-	102	-	11	F10	22	22.0

VALVE DATA

DIM		TORQUE*	WEIGHT	KV-VALUE	BUTT WELD ENDS	
[MM]	[INCH]	[NM]	[KG]	90° [m³/h]	TYPE E7624	TYPE E7621
					SCH. 40	ISO 1127
					øC/øE (MM)	øC/øE (MM)
DN08	1/4"	5.9	0.7	7	18.0/9.3 (4.35)	-
DN10	3/8"	5.9	0.7	7	18.0/12.5 (2.75)	-
DN15	1/2"	6.5	0.7	15	22.0/15.8 (3.10)	21.3/17.3 (2.0)
DN20	3/4"	7.8	0.9	31	28.0/20.9 (3.55)	26.9/22.9 (2.0)
DN25	1"	12.4	1.4	41	34.0/26.7 (3.65)	33.7/29.7 (2.0)
DN32	1 1/4"	24.7	2.1	80	43.0/35.1 (3.95)	42.4/38.4 (2.0)
DN40	1 1/2"	33.8	3.0	141	50.0/40.9 (4.55)	48.3/44.3 (2.0)
DN50	2"	49.4	4.3	177	61.0/52.5 (4.25)	60.3/56.3 (2.0)
DN65	2 1/2"	76.7	8.3	386	76.0/62.7 (6.65)	76.1/72.1 (2.0)
DN80	3"	131.3	11.9	668	92.0/78.0 (7.00)	88.9/84.9 (2.0)
DN100	4"	192.4	22.7	1165	115.0/102.4 (6.30)	114.3/110.3 (2.0)

* Torque figures include 30% safety factor. (TEST: 63bar diff. pressure, ambient temperature, non-lubricating).

PRESSURE/TEMPERATURE

