

# REMOTE PILOT FOR DIAPHRAGM VALVES- LD SERIES

## LONG-DISTANCE ACTIVATION



### FEATURES

Fluids	Non-lubricated filtered air
Operating pressure	between 0.5 and 7.5 bar
Operating temperature	-20°C; +80°C
Body	Brass
Pilot core	Stainless steel
Coil insulation	Class H
Connector	PG9 / IP 65
Standard voltage	230 -110 - 24V/50-60 Hz (19 VA) 24VDC (15W)
Maximum Valve Distance	10 Metres

### LDC

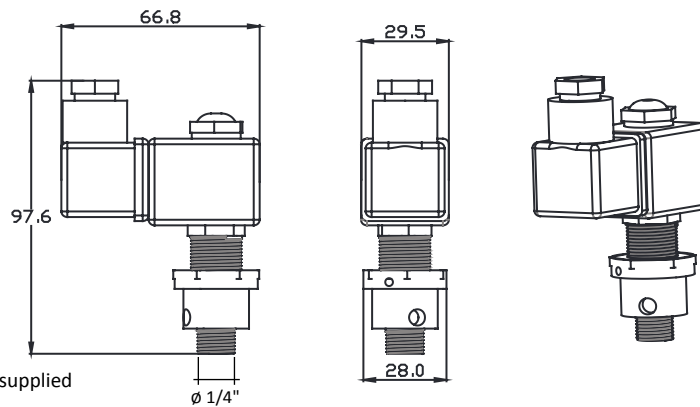

### LDM

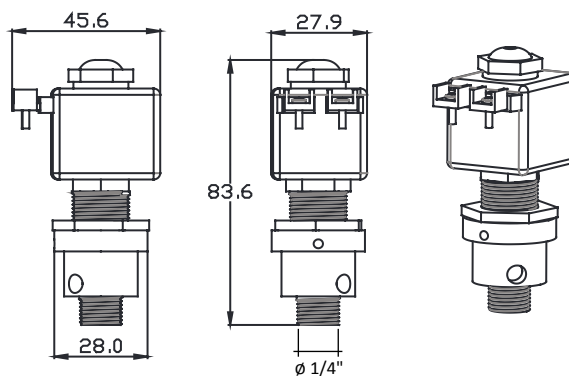

### MOUNTING EXAMPLE

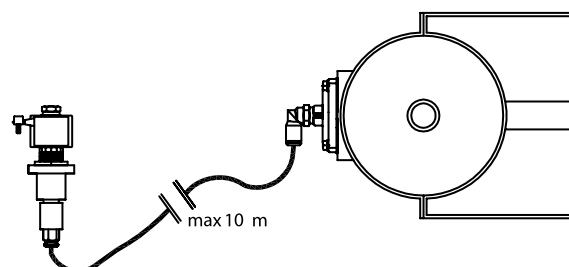

LD SERIES - REMOTE PILOT FOR DIAPHRAGM VALVES

LDC

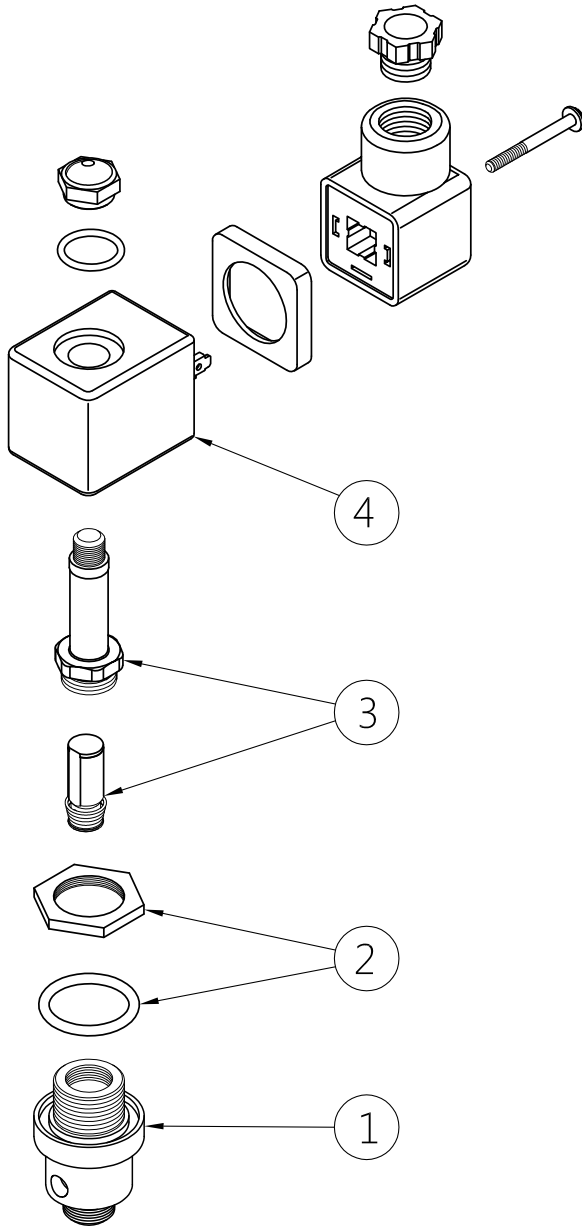

LDM

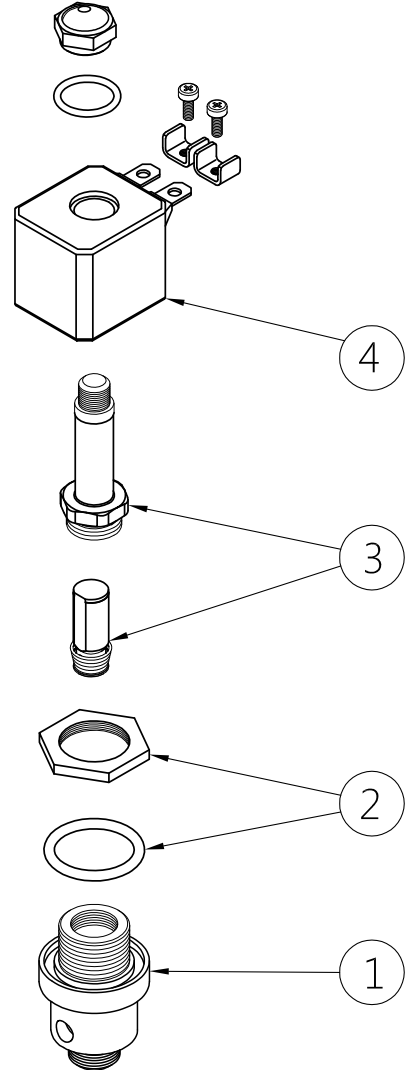

DESCRIPTION	LDC
1 Pilot body	PCRPLD
2 Second lock nut + O-ring	3121604 + 3301224
3 Pilot unit	1331172
4 Coil + Connector	BH10.../..

DESCRIPTION	LDM
1 Pilot body	PCRPLD
2 Second lock nut + O-ring	3121604 + 3301224
3 Pilot unit	1331172
4 Coil	BH10.../.. - A9