

Instrumentation Products

E Series Valves and Manifolds

Digital Valve Plate

Digital Valve Plate for Valves and Manifolds provides easy access to technical product information. Scan the QR-code (IEC 61406 compatible) or enter plain text serial number under:



www.qr4v.de



Optionally Available

Introduction

Introduction

The AS-Schneider Group with its headquarters in Germany is one of the World's Leading Manufacturers of Instrumentation Valves and Manifolds. AS-Schneider offers a large variety of E Series Valves and Manifolds as well as numerous accessories needed for the instrumentation installations globally.

Selection can be made from a comprehensive range of bodies with a variety of connections and material options, optimising installation and access opportunities. Many of the valves shown in this catalogue are available from stock or within a short period of time. The dimensions shown in this catalogue apply to standard types – very often 1/2 NPT threaded. If you need the dimensions for your individual type please contact the factory.

Note: Not every configuration which can be created in the ordering information is feasible / available.

Continuous product development may from time to time necessitate changes in the details contained in this catalogue. AS-Schneider reserves the right to make such changes at their discretion and without prior notice.

All dimensions shown in this catalogue are approximate and subject to change.

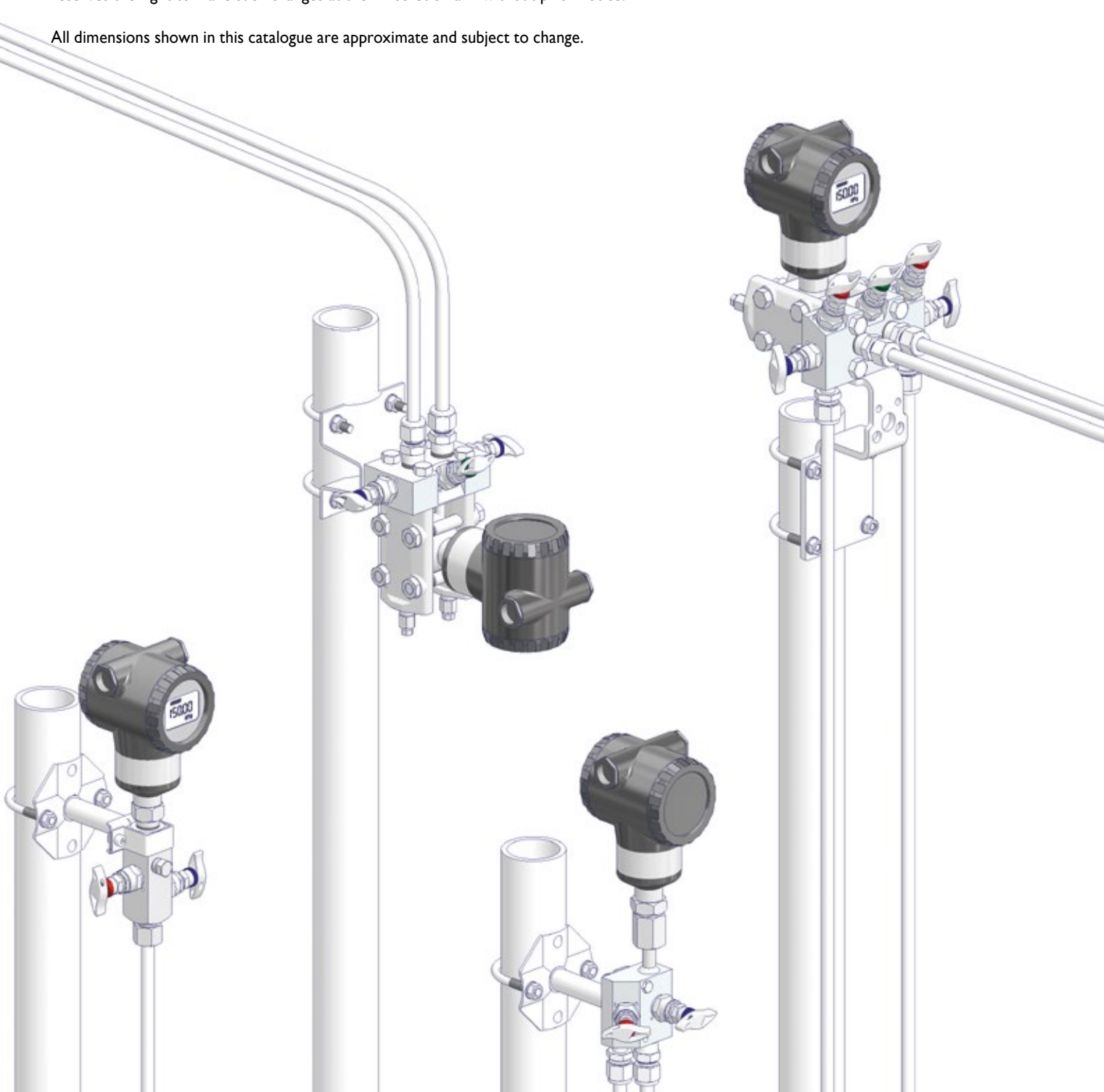

Introduction	page 2
Contents	page 3
General Features	page 4
Valve Head Unit Options	page 5-11
Connections	page 12-13
Hand Valves	page 14-15
Gauge Valves	page 16-17
Multiport Gauge Valves	page 18-19
Block & Bleed and Double Block & Bleed Manifolds	page 20-21
L, Y & W-Shaped Manifolds	page 22-24
Remote Mounted Manifolds	page 25-27
Direct Mount Manifolds	
Wafer Style	page 28-33
Traditional Style	page 34-37
Integral Style	page 38-40
5 Valve Manifolds with Natural Gas Metering Pattern	page 41-42
Enclosure Manifolds EDM Series	page 43-45
Differential Pressure Gauge Manifolds	page 46-47
Accessories	page 48-53
Check Valves	page 54
Complementary Products	page 55
Technical Service Portal - Digital Valve Plate (DVP)	page 56

General Features

Body Material Options

Material Group	AS Material Designation	Material No.	Short Name	Equivalent UNS-No.	Material Grade acc. to ASTM	E Series Needle Valves and Manifolds
Carbon Steel	A105				A105	Optional
Austenitic Stainless Steel	316 quadruple certified*	1.4401	X5CrNiMo17-12-2	S31600	316	Standard
		1.4404	X2CrNiMo17-12-2	S31603	316L	Standard
	6Mo	1.4547	X 1CrNiMoCuN20-18-7	S31254		Standard
Austenitic-Ferritic Stainless Steel	Duplex	1.4462	X2CrNiMoN22-5-3	S31803	F51	Standard
	Superduplex	1.4410	X2CrNiMoN25.7.4	S32750	F53	Standard
Nickel Based Alloys	Alloy 400	2.4360	NiCu30Fe	N04400		Standard
	Alloy C-276	2.4819	NiMo 16 Cr 15 W	N10276		Standard
	Alloy 625	2.4856	NiCr22Mo9Nb	N06625		Standard
	Alloy 825	2.4858	NiCr21Mo	N08825		Optional
Titanium	Titanium Grade 2	3.7035	Ti-II	R50400		Optional

* Quadruple Certified means 316 / 316L / 1.4401 / 1.4404

Standard Features

- Bore Size 5 mm
- Manifolds are not supplied with plugs unless specified.
- Anti-Tamper Head Unit Options see Page 11.

Needle Seal:

PTFE and Graphite Packings are available for all valve types. Alternatively O-Ring stem seal and Bellows Sealed Head Units – see Page 6–10.

Sour Gas Service:

Wetted Parts according to a.m. material list are supplied as standard according to NACE MR0175/MR0103 and ISO 15156 (latest issue) – Standard Material only (see last column), except Titanium Grade 2.

Pressure Test:

A shell test and a seat leakage test are performed at 1.5 times the max. allowable (working) pressure acc. to EN 12266-1 – P10, P11 and P12 respectively MSS-SP61 at every standard AS-Schneider E Series Needle Valve / Manifold → 100% Pressure Tested!

Certification:

Inspection Certificate 3.1 acc. to EN 10 204 for valve body material and pressure test available on request.

The manifolds can be provided by default with a

- CRN Certificate
- EAC Certificate – Manifolds are marked with EAC

Valves with Graphite Packings are Fire Safe Tested and Certified according to ISO 10497 and API 607.

Optional Features

- Soft Seated Needle Valves: Bore Size 6.35 mm (1/4")
- Bore Size 10 mm

Fugitive Emission Application:

For Fugitive Emission Applications AS-Schneider is providing bellows sealed valves with safety packing. Choice of Pressure class PN 100 or PN 250. The bellows are submitted to a 100% Helium leak test. The leak rate is 10^{-8} mbar l/s. Optional available are TA-Luft and ISO 15848 solutions. For more details see Pages 9 and 10.

Oxygen Service:

AS-Schneider offers an option with Reinforced PTFE Packing cleaned and lubricated for Oxygen Service:

Pressure-Temperature Rating:

Max. 420 bar (6,092 psi) @ 60°C (140°F)

Max. 200°C (392°F) @ 90 bar (1,305 psi)

Not every Valve Type is available for Oxygen Service!

If you don't find your options in this catalogue, please contact the factory.

Standard Bonnet Design

T Handle

Ergonomic Handle Design.
Operating options are Anti-Tamper features or a Stainless Steel Handwheel.

Valve Stem

Stem with cold rolled threads for high strength and smooth operation.

Needle Seal

Standard: PTFE or Graphite Packing
Options: O-Ring or Bellows Sealed

Needle

Non-rotating Needle for smooth operation and minimum wear of sealing elements.

Back Seat

Metal to Metal secondary needle seal and therefore the needle is anti-blowout / non-removable – For your safety.

Needle Tip

Choices of Needle Tip Materials such as Stellite, and Soft Tips like PCTFE and POM.

Valve Seat

Metal seated (integral type) and Soft seated → See Page 7 and Catalogue AS-4302.



Color Coded Dust Cap

For operating thread protection:

Isolate	BLUE
Vent/Test	RED
Equalize	GREEN

Color Coded Options

Following options are also color coded below dust cap:

Oxygen Service	WHITE
Graphite Packing	BLACK
FKM O-ring Stem Seal with PCTFE Soft Tip	ORANGE
TA-Luft Option	MAGENTA

Lock Pin

Eliminates unauthorized removal of the bonnet assembly.

Bonnet

Metal to Metal Seal to Valve Body.

Traceability of Materials

All AS-Schneider E Series Valves and Manifolds have material traceability. A unique code is stamped on all valve bodies linking them with their material and chemical analysis certificates.

Flow Data

Needle Valves Standard Head Unit – Bore Size 5 mm

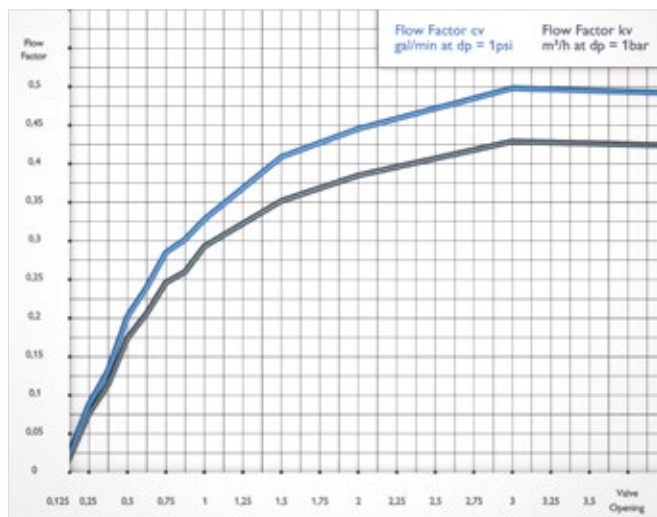

Standard Valve Head Units

Standard Needle Valves

Screwed Bonnet – Stem Seal: Packing

Features

- Integral Valve Seat – Metal to Metal Seated
- Soft Tip PCTFE or POM optional
- Non-rotating Needle
- External Stem Thread – Packing below stem threads. Stem Threads are protected from process media (non-wetted), helps to prevent stems from galling.
- Stem with cold rolled threads
- Blow-out proof Needle
- Back Seat – Metal to metal secondary needle seal
- Lock Pin – Eliminates unauthorized removal of the bonnet
- Color Coded Dust Cap for operating thread protection
- Standard Packing in PTFE and Graphite available
- Carbon filled PTFE Packing - TA-Luft option
- Max. allowable (Working) Pressure (PS):
420 bar (6,092 psi)
– 689 bar (10,000 psi) optional
- Panel Mount Option available
- Anti-Tamper Valve Head Options available
- All non-wetted parts in 316 stainless steel

Standard Design
420 bar (6,092 psi)

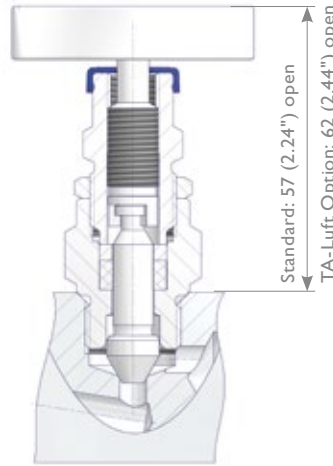

High Pressure Design
689 bar (10,000 psi) and
500 bar (7,252 psi)

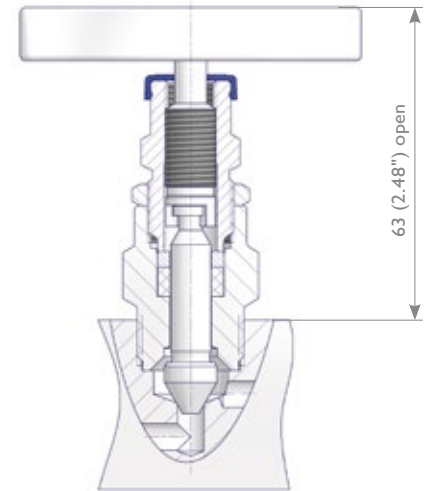

Body-to-Bonnet Seal is below the threads eliminating process fluid corrosion.

Color Coded Options

Graphite Packing



Oxygen Service



TA-Luft Option



Panel Mount Option

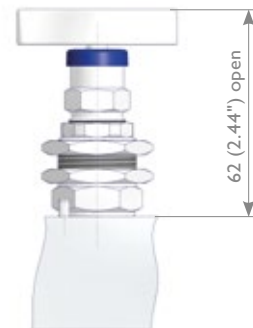

Components	Stainless Steel		Exotic Alloys					
	Material / Material No.							
Body	316 / 316L	Alloy 400	Alloy C-276	Duplex	UNS S32750	Alloy 625	6Mo	Titanium Gr. 2
Bonnet								
Needle								
Pipe Plug								
Valve Stem	316 / 316L							
Gland	316							
Packing	PTFE or Graphite							
Stem Nut	316							
Lock Nut	316							
Set Screw	316							
T Handle	316							
Lock Pin	A4 (316)							

Wetted components listed in **bold**.

Needle Valves according ASME B31.1 (Power Piping)

Screwed Bonnet – Stem Seal: Graphite Packing
 Meet the requirements of ASME B31.1 (Power Piping).
 A Locking Plate eliminates an unauthorized removal of the bonnet.

Features

- Integral Valve Seat – Metal to Metal Seated
- Non-rotating Needle
- External Stem Thread – Packing below stem threads.
 Stem Threads are protected from process media (non wetted), helps to prevent stems from galling.
- Stem with cold rolled threads
- Blow-out proof Needle
- Back Seat – Metal to metal secondary needle seal
- Locking Plate – Eliminates unauthorized removal of the bonnet
- Color Coded Dust Cap for operating thread protection
- Max. allowable (Working) Pressure (PS): 414 bar (6,000 psi)
- Anti-Tamper Valve Head Options available
- All non-wetted parts in 316 stainless steel

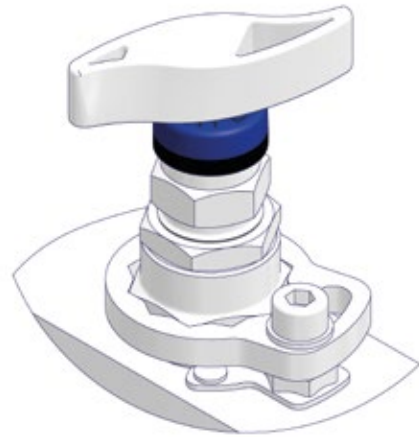

Needle Valves with O-Ring Stem Seal

Screwed Bonnet – O-Ring Stem Seal

Features

- Integral Valve Seat
- Non-rotating Needle
- External Stem Thread – Packing below stem threads.
 Stem Threads are protected from process media (non-wetted), helps to prevent stems from galling.
- Stem with cold rolled threads
- Blow-out proof Needle
- Back Seat – Metal to metal secondary needle seal
- Lock Pin – Eliminates unauthorized removal of the bonnet
- Color Coded Dust Cap for operating thread protection
- O-Ring FKM, optional EPDM
- Soft Tip PCTFE or POM
- Max. allowable (Working) Pressure (PS): 420 bar (6,092 psi)
- Panel Mount Option not available
- Anti-Tamper Valve Head Options available
- All non-wetted parts in 316 stainless steel

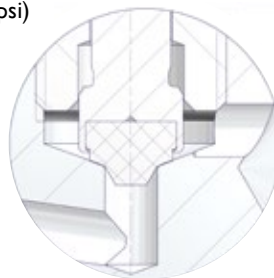
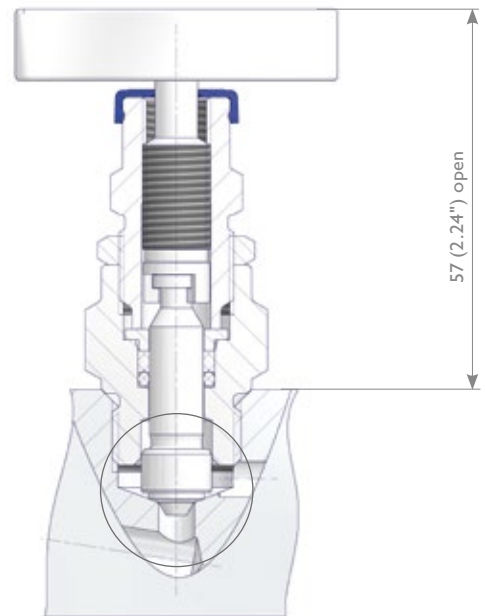

Color Coded Option
 FKM O-Ring Stem Seal
 with PCTFE Soft Tip

Standard Valve Head Units

Needle Valves with OS&Y Bolted Bonnet

OS&Y Bolted Bonnet – Standard Packing

Features

- Integral Valve Seat – Metal to Metal Seated
- Non-rotating Needle
- External Stem Thread – Packing below stem threads. Stem Threads are protected from process media (non-wetted), helps to prevent stems from galling.
- Stem with cold rolled threads
- Blow-out proof Needle
- Spring Washers for compensation of thermal expansion
- Back Seat – Metal to metal secondary needle seal
- Color Coded Dust Cap for operating thread protection
- Max. allowable (Working) Pressure (PS): 420 bar (6,092 psi)
- Anti-Tamper Valve Head Options available
- PTFE or Graphite Packing
- Bonnet Seal Ring: Graphite
- All non-wetted parts in 316 stainless steel

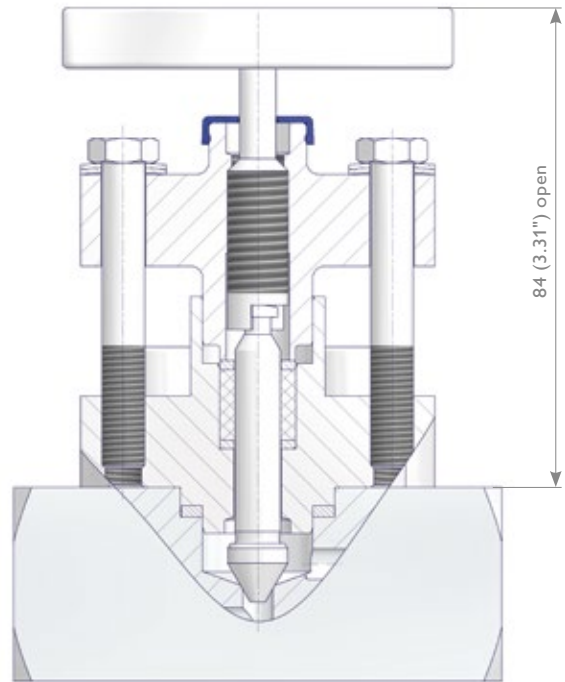

Pressure-Temperature Rating for Standard Valve Head Units acc. to Page 6 – 8

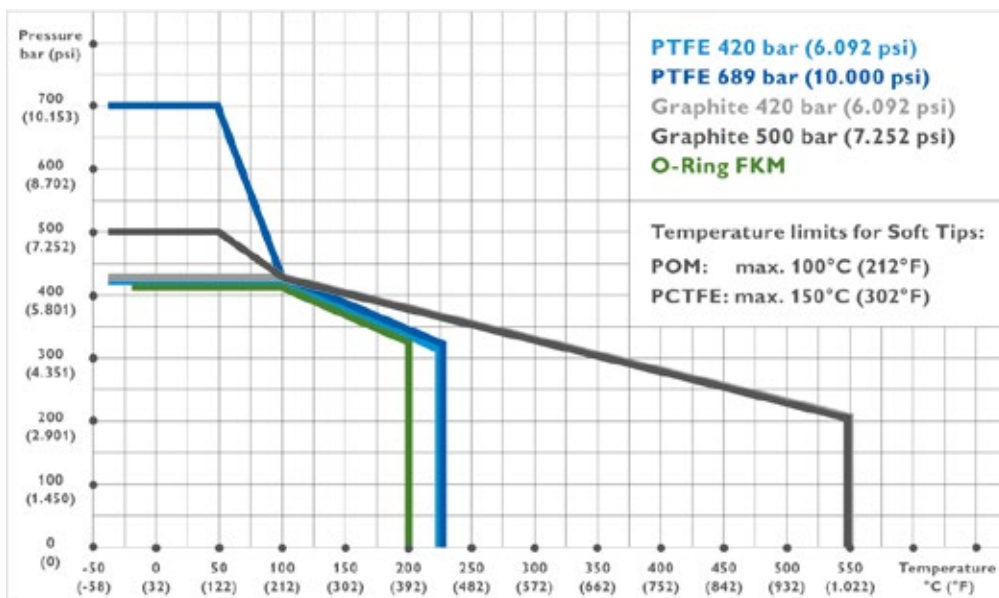

Above-mentioned Pressure-Temperature Rating is based on the standard material 316 stainless steel. Other materials as shown on page 4 and 6 might have different Pressure-Temperature Ratings.

Low-temperature Limits:

- Standard Valves with PTFE and Graphite Packing: -40°C (-40°F)
- Valves with PTFE Packing and Arctic Operations Option, Code K: -55°C (-67°F)
- Valves with FKM O-Ring Needle Seal: -20°C (-4°F)
- Carbon Steel ASTM A105: -29°C (20.2°F)



Packing adjustment may be required during the service life of the valves.



Valves that have not been cycled for a period of time may have a higher initial actuation torque.

Valve Head Units for Fugitive Emission Applications

Needle Valves acc. to ISO 15848

Screwed Bonnet – Type 1 O-Ring Stem Seal + Graphite Packing
Type 3 PTFE Packing

Features

- Integral Valve Seat – Metal to Metal Seated
- Non-rotating Needle
- External Stem Thread – Packing below stem threads. Stem Threads are protected from process media (non-wetted), helps to prevent stems from galling.
- Stem with cold rolled threads
- Back Seat – Metal to metal secondary needle seal
- Color Coded Dust Cap for operating thread protection
- Max. allowable (Working) Pressure (PS): 420 bar (6,092 psi)
- Anti-Tamper Valve Head Options available
- FKM O-Ring Needle Seal – RGD (Rapid Gas Decompression) resistant
- PTFE or Graphite Packing
- All non-wetted parts in 316 stainless steel
- Types also comply with the requirements of TA-Luft 2002

ISO FE Performance Data

ISO FE Type 1:
Class A 1,500 cycles / -29°C to 40°C
(-20°F to 104°F)
Class A 500 cycles / -29°C to 200°C
(-20°F to 392°F)
Class B 1,500 cycles / -29°C to 200°C
(-20°F to 392°F)

ISO FE Type 3:
Class B 1,500 cycles / -29°C to 200°C
(-20°F to 392°F)

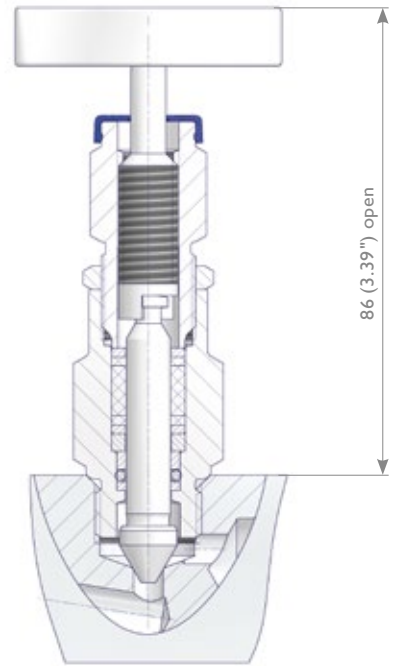

OS&Y Needle Valves acc. to ISO 15848

OS&Y Bolted Bonnet – Type 1 O-Ring Stem Seal + Graphite Packing
Type 3 PTFE Packing

Features

- Integral Valve Seat – Metal to Metal Seated
- Non-rotating Needle
- External Stem Thread – Packing below stem threads. Stem Threads are protected from process media (non-wetted), helps to prevent stems from galling.
- Stem with cold rolled threads
- Blow-out proof Needle
- Spring Washers for compensation of thermal expansion
- Back Seat – Metal to metal secondary stem seal
- Color Coded Dust Cap for operating thread protection
- Max. allowable (Working) Pressure (PS): 420 bar (6,092 psi)
- Anti-Tamper Valve Head Options available
- FKM O-Ring Stem Seal – RGD (Rapid Gas Decompression) resistant
- PTFE or Graphite Packing
- Bonnet Seal Ring: Graphite
- All non-wetted parts in 316 stainless steel
- Types also comply with the requirements of TA-Luft 2002

ISO FE Performance Data

Class A 2,500 cycles / -29°C to 40°C
(-20°F to 104°F)
Class A 500 cycles / -29°C to 200°C
(-20°F to 392°F)
Class B 2,500 cycles / -29°C to 200°C
(-20°F to 392°F)

ISO FE Type 3:
Class B 2,500 cycles / -29°C to 200°C
(-20°F to 392°F)

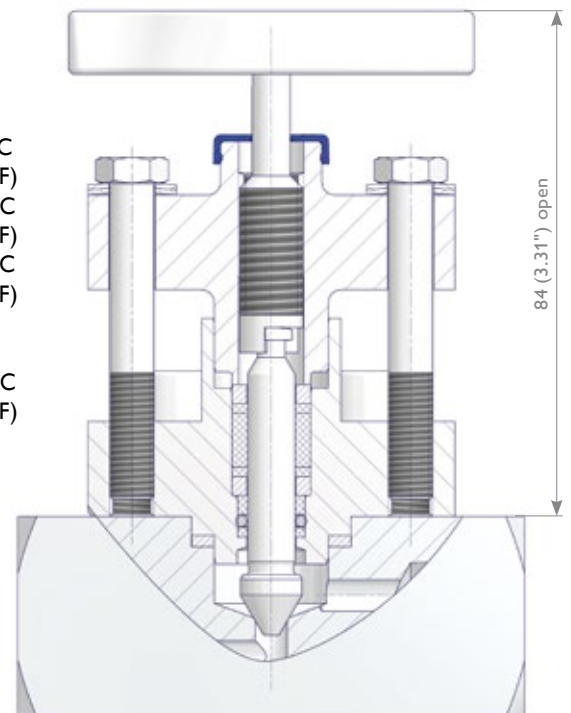

Valve Head Units for Fugitive Emission Applications

Bellows Sealed Head Units

Screwed Bonnet – PN 100 and Graphite Safety Packing
PN 250 and Graphite Safety Packing

Features

- Integral Valve Seat – Metal to Metal Seated
- Non-rotating Stem
- Bellows sealed – PN 100 and PN 250 incl. Graphite Safety Packing
- Stem with cold rolled threads
- Stellite Needle Tip as standard
- Bellows are submitted to a 100% Helium leak test
- Leak rate: 10^{-8} mbar l/s
- Valves for Oxygen Service on request

Bellows Sealed Head Units are mainly used for applications requiring the highest tightness class – such as toxic or vacuum service.

- ⚠ **Packing adjustment may be required during the service life of the valves.**
- ⚠ **Valves that have not been cycled for a period of time may have a higher initial actuation torque.**
- ⚠ **When delivered ex factory, the safety packing of the bellows sealed valve is not fully tightened. In the event of a bellows failure the safety packing must be tightened in order to avoid fluid leakage.**

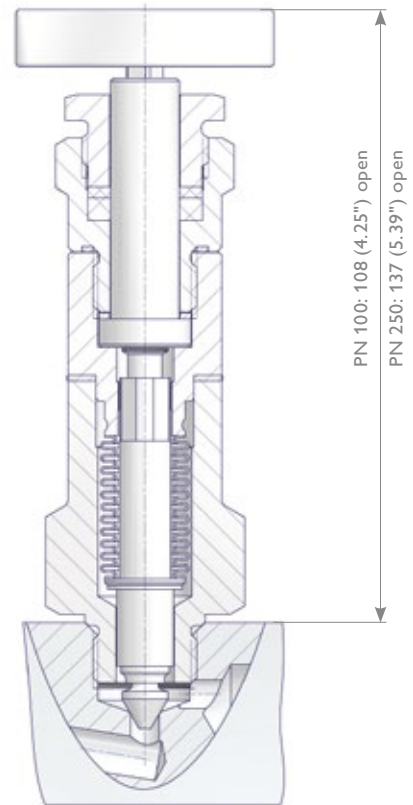

Pressure-Temperature Rating

ISO FE Type 1 FKM O-Ring and Graphite Packing
ISO FE Type 3 PTFE Packing

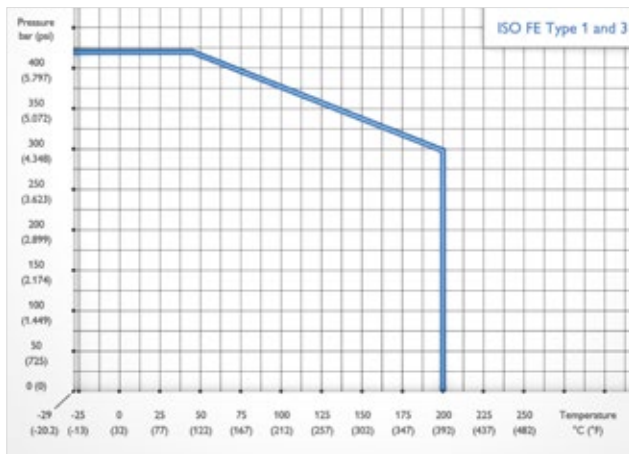

Pressure-Temperature Rating

Bellows PN 100 Safety Packing Graphite
Bellows PN 250 Safety Packing Graphite

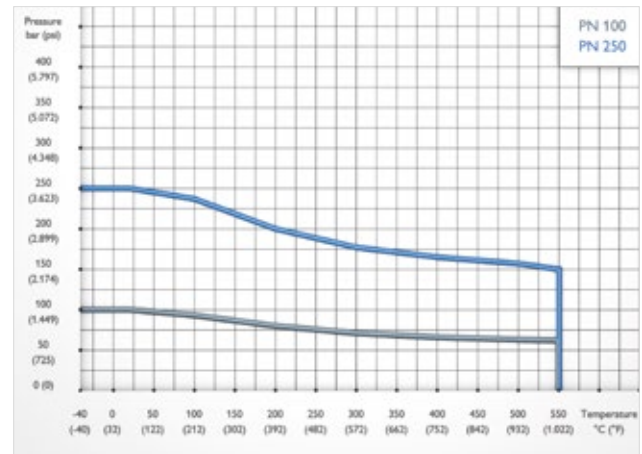

Above-mentioned Pressure-Temperature Rating is based on the standard material 316 stainless steel.

Other materials as shown on page 4 and 6 might have different Pressure-Temperature Ratings.

Anti-Tamper Valve Head Unit Options

AS-Schneider is providing 2 Anti-Tamper Valve Head Units, both types are lockable with a padlock.

Standard Anti-Tamper Head Unit

The valves are operated with a special Anti-Tamper Key (AT-Key), which fits exactly in the key guide. The valve can therefore only be operated with the AT-Key. In addition to this safety function, installing a padlock prevents the AT-Key being inserted into the key guide. Operating the valve is therefore no longer possible which protects your equipment against unauthorized opening and closing of the valve head units. The valve can be locked reliably in every position required.



Option Code T or R



Part Number ATK-ES

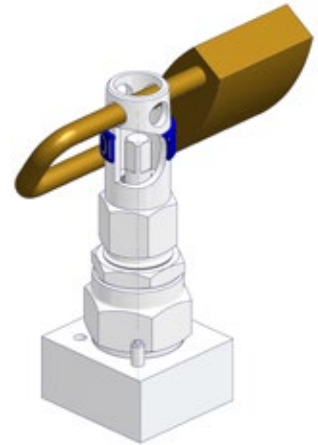

Incl. Padlock; Option Code U

'AT-Key Lock' Anti-Tamper Head Unit (Option Code Q)

'AT-Key Lock' valves are operated by a AT-Key which is an integral component of the valve. This Key can be extracted a little from the valve head unit which loosens the connection between the valve stem and the Key. In this extended position a padlock can now be hooked diagonally in the valve head unit which prevents the Key being inserted again. Operating the valve is therefore no longer possible which protects your equipment against unauthorised opening and closing of the valve. The valve can be locked reliably in every position required. This design offers you optimal security against unintentional and unauthorized operation of the valve. A color coded dust cap protects stem threads against ingress of dirt unauthorized opening and closing of the valve head units. The valve can be locked reliably in every position.

Stainless Steel Handwheel and 'Locking Plate' Design

The valves can be ordered optional with Stainless Steel Handwheel (Option Code W) and also with an additional fitted locking plate (Option Code J). For ordering the 'Locking Plate' Design incl. padlock you need to state J and U. This design allows minimum handle movements and is ideal as protection against unauthorised closing of the valve.

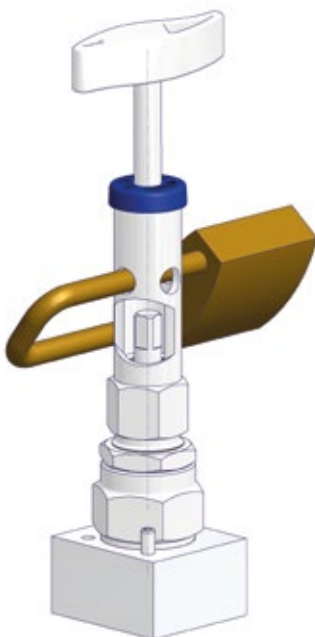

Option Code Q



Option Code J

Stainless Steel Handwheel



Option Code W

Connections

Connections

AS-Schneider is manufacturing a lot of different connections and connection combinations. In this catalogue we are showing the most popular types. On the next 2 pages you will find the standard connections in detail. If you don't find your option please contact us.

Designations used in the tables: Inlet = Process Connection | Outlet = Instrument / Transmitter Connection

Tube Fittings

Single Ferrule Tube Fittings
acc. to EN ISO 8434-1 Size S



Twin Ferrule Tube Fittings

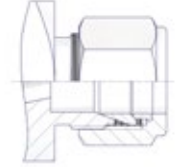

Tapered Pipe Threads

NPT Male Threads
acc. to ASME B 1.20.1

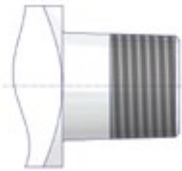

NPT Female Threads
acc. to ASME B 1.20.1

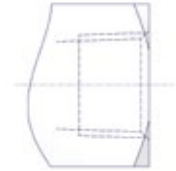

BSP Tapered Thread
acc. to ISO 7/1 (e.g. R 1/2)

BSP Tapered Thread
acc. to ISO 7/1 (e.g. Rc 1/2)

Parallel Pipe Threads

BSP Parallel Male Thread
acc. to ISO 228 (e.g. G 1/2)
acc. to DIN 3852
acc. to EN 837-1



BSP Parallel Female Threads
acc. to ISO 228 (e.g. G 1/2)
acc. to DIN 3852-2 Form Z
acc. to ISO 7/1 (e.g. R 1/2)
acc. to EN 837-1

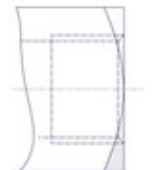

Weld Ends

Butt Weld Ends for
Pipes and Tubes acc. to
EN12627 / ASME B16.9



Socket Weld Ends for
Pipes and Tubes acc. to
EN12760 / ASME B16.11



Pressure Gauge Connections - For Parallel Pipe Threads only

Swivel Male Connection

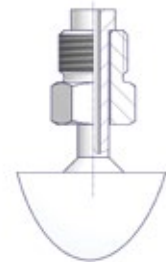

Adjusting Nut
acc. to DIN 16283

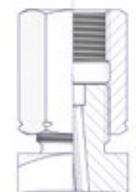

Swivel Nut (Wire Design)

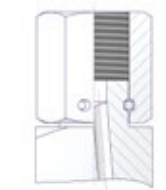

Swivel Nut
(Welded Nipple Design)
acc. to DIN 16284



Flange Connections

According to DIN EN 61518 the manifold-transmitter interface is applicable for a max. allowable (Working) Pressure (PS) of 413 bar*³ (6,000 psi) and a max. allowable Temperature (TS) of 120°C (248°F) for liquids, gas or vapors. The max. allowable Temperature (TS) of 120°C (248°F) is considering the requirement that manifolds and transmitters need to be protected against heating by hot media. This can be achieved by using adequate hook-ups or by instrument impulse lines with sufficient length. However the AS-Schneider E Series Manifolds can be used for temperatures up to 550°C (1,022°F), PTFE up to 232°C (450°F), Graphite up to 550°C (1,022°F).

Flange Connections – Inlet Manifold respectively Transmitter Connection DIN EN 61518 / IEC 61518

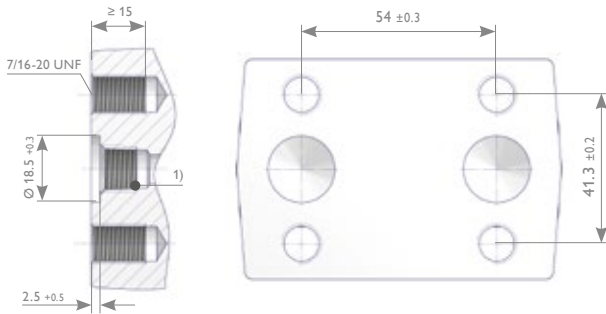

¹ Threaded option for transmitters – plug / vent valve

Flange Connections – Manifold to Transmitter DIN EN 61518 / IEC 61518 Type A and Type B

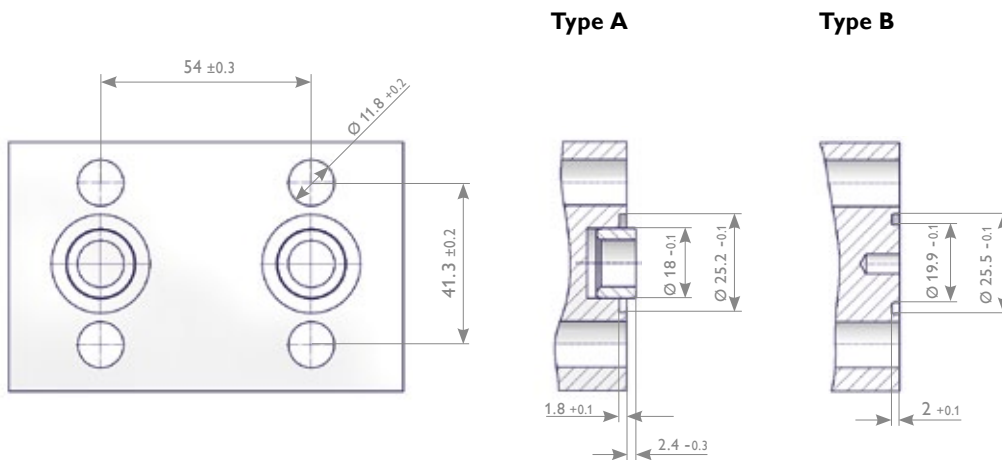

	Connection at the manifold acc. to IEC 61518 / DIN EN 61518* ¹ * ³				
	Type A with spigot			Type B without spigot	
Max. allowable (Working) Pressure (PS) in bar (psi)	413 (6,000)* ³			413 (6,000)* ³	
Temperature Range in °C (°F)	-10 to +80 (14 to 176)	-15 to +120 (5 to 248)	-40 to +120 (-40 to 248)	-10 to +80 (14 to 176)	-40 to +120 (-40 to 248)
Seal Ring* ²	Flat Ring 24 x 17.7 x 2.7 Material: PTFE	O-Ring ISO 3601-1 20 x 2.65 S-FPM90 Material: FPM (FKM by ASTM)	Flat Ring 25.1 x 18 x 2.9 Material: Graphite	Flat Ring 25.4 x 20 x 2.7 Material: PTFE	Flat Ring 25.4 x 19.9 x 2.9 Material: Graphite
Min. Thread Engagement in mm	9			9	

*¹ DIN EN 61518 / IEC 61518 | Mating dimensions between pressure measuring instruments and flanged-on shut-off devices up to 413 bar (6,000 psi).

*² Materials and temperature limits for the flat rings and the O-Rings are for reference only. It is the responsibility of the user to ensure compatibility between the selected gasket ring material and the process requirements, such as pressure, temperature, and chemical compatibility.

*³ IEC 61518 is stating 413 bar (6,000 psi), AS-Schneider however confirms 420 bar (6,092 psi).

Block & Bleed and Double Block & Bleed Manifolds

Block & Bleed and Double Block & Bleed Manifolds

AS-Schneider Block & Bleed and Double Block & Bleed Manifolds are designed for mounting to Pressure Gauges, Pressure Transmitters and Pressure Switches. The standard vent connection is 1/4 NPT female. Pipe plugs are not installed as standard. For plugged vent ports (factory installed) – see also options next page – Ordering Information Block & Bleed Manifolds. Accessories like Swivel Gauge Adaptors, Vent Valves etc. see Pages 48-53.

The dimensions shown apply only to the illustrated valves (1/2 NPT Threaded) – if you need the dimensions for your individual type or should you still not find your options at all please contact the factory.

Block & Bleed Manifolds – Female Threaded Instrument Connection

SAFF Type

SAMF Type

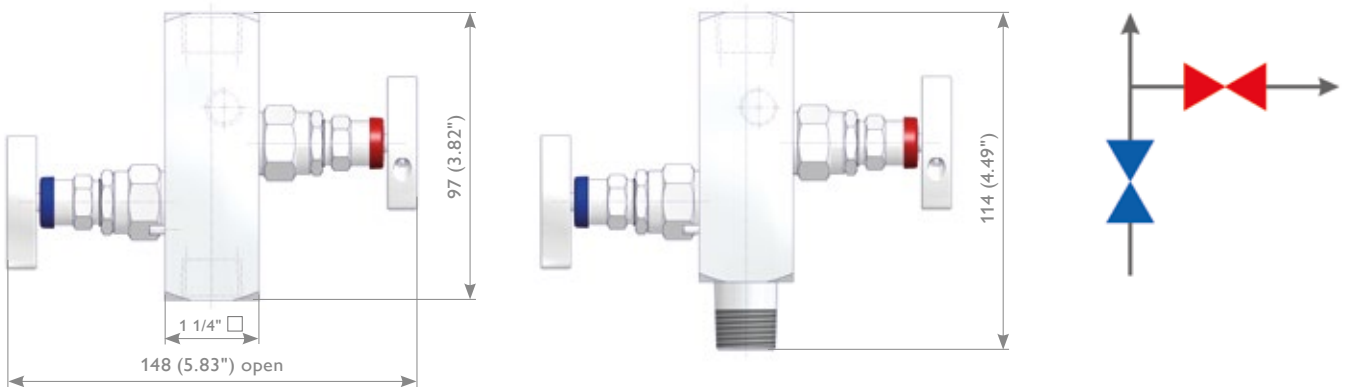

Double Block & Bleed Manifolds – Female Threaded Instrument Connection

CAFF Type

CAMF Type

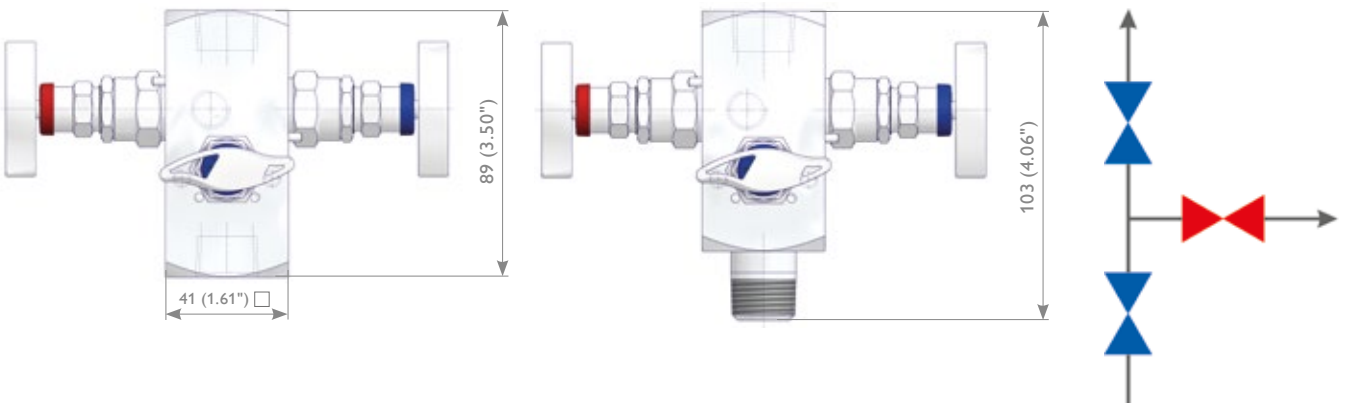

Block & Bleed and Double Block & Bleed Manifolds

Ordering Information

	1	2	3	4	5	6	7	8	9	10	11	12	13	14	15	16	
	S	A	M	F	M	A	-	N	4	N	4	-	9	Q	U		
S	Block & Bleed Manifolds																
C	Double Block & Bleed Manifolds																
Vent Connection																	
A	1/4 NPT Female		C	G 1/4 Female													
B	1/2 NPT Female		D	G 1/2 Female													
Inlet																	
M	Male		B	Butt Weld End													
F	Female		S	Socket Weld End													
T	Integral Tube Fitting		A	1/2 NPT with Tube Fitting													
Outlet																	
M	Male		G	Adjusting Nut (For Connection Code G2, G4 and M4 only)													
F	Female		D	Swivel Nut [Wire Design] (For Connection Code G2, G4 and M4 only)													
Material																	
S	1.4401 / 1.4404 / 316 / 316L		F	Duplex UNS S31803		B	6Mo UNS S31254										
M	Alloy 400 UNS N04400		D	Super Duplex UNS S32750		T	Titanium Grade 2										
H	Alloy C-276 UNS N10276		V	Alloy 625 UNS N06625													
Bonnet																	
A	PTFE		K	O-Ring FKM (FPM by ISO)													
B	Graphite		W	Carbon filled PTFE – TA-Luft													
D	ISO FE Series Type 1		2	Bellows sealed PN 100													
E	ISO FE Series Type 3		4	Bellows sealed PN 250													
Inlet																	
Thread Type																	
N	NPT		C	Single Ferrule Tube Fitting		4	1/2" Pipe		D	For 12 mm Tube (Ø 12.2 mm)							
G	BSP Parallel (G) – EN 837-1		K	Twin Ferrule Tube Fitting		6	3/4" Pipe		E	For 14 mm Tube (Ø 14.25 mm)							
H	BSP Parallel (G) – DIN 3852					D	12 mm		2	For 1/4" Pipe							
R	BSP Taper (R/Rc) – ISO 7/1					E	14 mm										
M	Metric similar to EN 837-1																
Inch Sizes																	
2	1/4		4	12 resp. 12S		P	Schedule 80		A	Socket Weld							
4	1/2		5	14 resp. 14S		Q	Schedule 160										
6	3/4		9	1/2"		2	2.0 mm										
						8	2.6 mm										
						A	3.2 mm										
Metric Size																	
4	M20 x 1.5																
Outlet																	
Male / Female Thread Sizes																	
N2	1/4 NPT Female Thread only					G2	G 1/4 (1/4 BSP P)										
N4	1/2 NPT					G4	G 1/2 (1/2 BSP P)										
R4	R/Rc 1/2 – ISO 7/1 (1/2 BSPT) Female Thread only					M4	M20 x 1.5										
Options - Specify in alphabetical order (digits first, then letters)																	
B	Cleaned and Lubricated for Oxygen Service – For PTFE Packing only																
F	PCTFE Soft Tip																
G	POM Soft Tip																
S	Stellite Valve Tip																
A	Vent Ports Plugged																
H	10,000 psi (689 bar) for PTFE Packing 7,252 psi (500 bar) for Graphite Packing																
P	Power Piping ASME B31.1 – For Graphite Packing only																
K	Arctic Operations (-55°C (-67°F)) – For PTFE Packing only																
M	Wetted Parts with 3.1 certificate																
Operation Options																	
J	Stainless Steel Handwheel with Locking Plate Design																
T	Anti-Tamper Bonnet (Key to be ordered separately)																
R	Anti-Tamper Bonnet (1 Key supplied per Valve/Manifold)																
Q	AT-Key Lock Bonnet Design																
U	Padlock for Anti-Tamper Bonnet / AT-Key Lock Bonnet Design																
W	Stainless Steel Handwheel																
Accessory Kits																	
8	SST Mounting Bracket AKM-S Type for 2" Pipe Mounting supplied separately – For Vertical Impulse Piping Installations of Block & Bleed Manifolds Type S																
9	SST Mounting Bracket AKM-G Type for 2" Pipe Mounting supplied separately – For Vertical Impulse Piping Installations of Double Block & Bleed Manifolds Type C																

Wetted Parts according to above mentioned material list are supplied according to NACE MR0175/MR0103 and ISO 15156 (latest issue) - except Titanium Grade 2.
 Note: Not every configuration which can be created in the ordering information is feasible / available.

Accessories – Mounting Bracket Kits

Mounting Bracket Kits for Vertical Impulse Piping Installations

AKM-S Type

For Valves and Manifolds with 1 1/4" Square Valve Body (Type H, G, M and S)

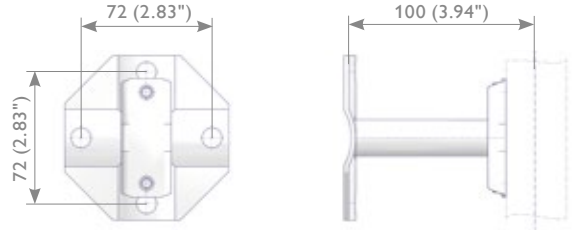

AKM-R Type

For Manifolds with 1 1/4" Flat Body (Type P and R)

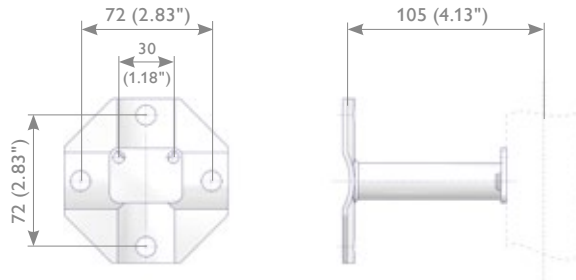

AKM-G Type

For Double Block & Bleed Manifolds (Type C)

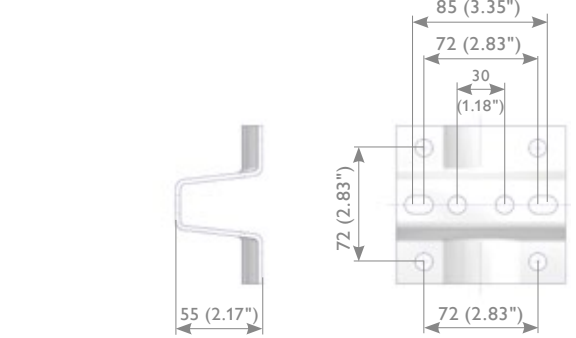

AKM-D Type and AKM-C Type

For Manifolds Type D, W and 5

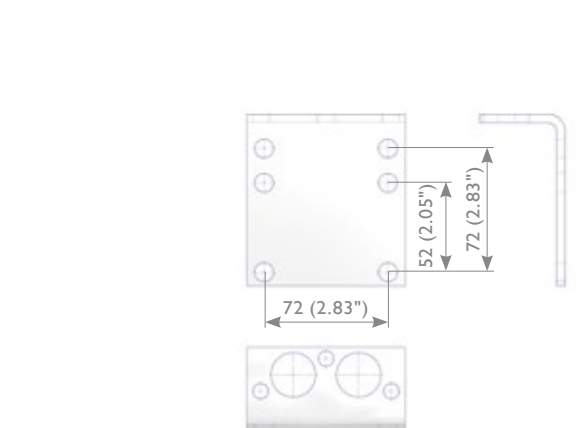

AKM-B Type

For Wafer Style Manifolds with Bottom Inlet Design

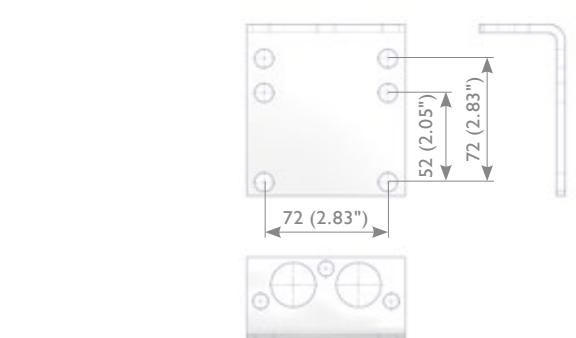
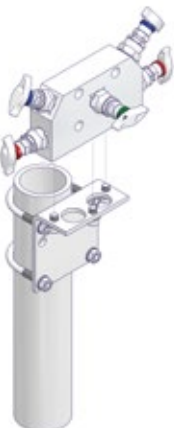

Accessories – Mounting Bracket Kits

Mounting Bracket Kits for Horizontal Impulse Piping Installations

AKM-T Type

For Integral Manifolds – Traditional Style

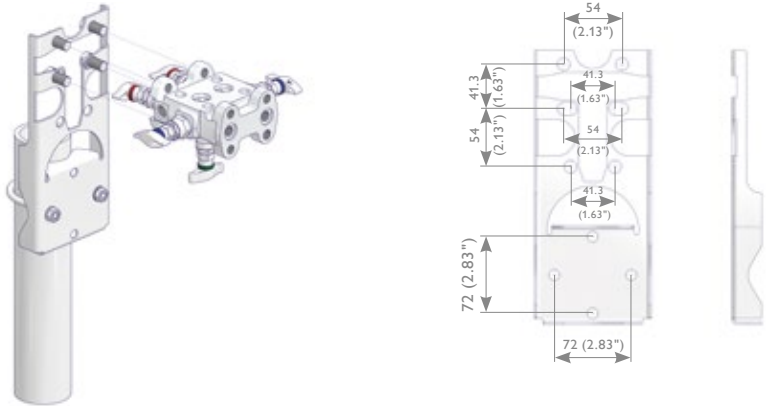

Mounting Bracket Kits for Horizontal and Vertical Impulse Piping Installations

AKM-U Type

For Manifolds Type H, W and T



Ordering Information

	1	2	3	4	5	6	7	8	9
	A	K	M	-	S	P	S	-	
AKM Mounting Bracket Kits									
Mounting Bracket incl. screws for mounting the bracket to the manifold (if applicable)									
S	Valves and Manifolds with 1 1/4" Square Valve Body (Type H, G, M and S)								
R	Manifolds with 1 1/4" Flat Body (Type P and R)								
G	Manifolds Type C								
D	Manifolds Type D, W and 5								
B	Wafer Style Manifolds with Bottom Inlet Design								
U	Manifolds Type H (not for Integral Manifolds for Rosemount 2051/3051 Coplanar™ Pressure Transmitters)								
	Manifolds Type W (except Bottom Inlet Design)								
	Manifolds Type T								
C	Integral Manifolds - Coplanar™ Style								
T	Integral Manifolds - Traditional Style								
Mounting Method									
P	2" Pipe Mounting – incl. 'U' Bolt, Nuts and Washers								
Material									
C	Carbon Steel zinc plated (only available Mounting Bracket Kit AKM-D and AKM-C)								
S	316 Stainless Steel								
H	Mandatory for Manifolds Type H and U-Type Bracket (incl. Spacer)								

Mounting Bracket Kit

Mounting Bracket Kits on Page 48 and 49 are containing:

- Mounting Bracket
- 'U' Bolts*
- Washers – 8.4*
- Hexagon Nuts M8*
- Screws and Washers for Mounting the Manifold to the Bracket – if applicable

* Amount depending on bracket type. See illustrations.

Accessories – Manifold to Transmitter Mounting acc. to DIN EN 61518

Accessory Kits for Manifold to Transmitter Mounting according to DIN EN 61518 / IEC 61518

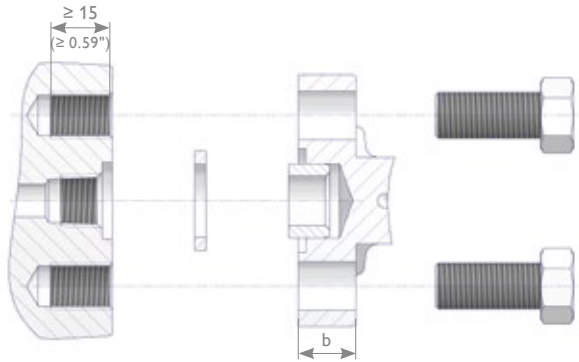

b = Depending on manifold thickness

Ordering Information

	1	2	3	4	5	6	7	8	9	10	11	12	13	14	15	16	
	A	K	S	-	H	U	4	C	-	P	A	F	4	4			
AKS Transmitter Mounting Kit																	
Type of Screw																	
H	Hex Cap Screw																
S	Socket Head Cap Screw																
Thread Size																	
U	7/16-20 UNF – For Traditional Style Manifolds (see page 34-37) please use Option Code W – Incl. washer																
M	M10 – Max. allowable (Working) Pressure (PS): 160 bar (2,320 psi) – Screws supplied with Washer																
W	7/16-20 UNF – Screws supplied with Washers																
Number of Screws and Seal Rings																	
2	2 Screws and 1 Seal Ring For 2 Valve Manifolds and Oval Flanges																
4	4 Screws and 2 Seal rings For Differential Pressure Manifolds																
5	4 Screws and 1 Seal Ring For 2 Valve Manifolds Type H2A - For Gauge/Absolute Pressure Transmitters																
8	4 Screws and 4 Seal Rings For Wafer Style Manifolds together with Oval Flanges - Screw Length 2 3/4"																
Material*																	
C	Carbon Steel UNF Thread: Hex Cap Screw ASTM A449 - Type 1 Socket Head Cap Screw ASTM A574 Metric Thread: ISO 898-1 Class 8.8																
S	316 Stainless Steel UNF Thread: ASTM A193 B8M Class 2 Metric Thread: ISO 3506 A4-70																
F	316 Stainless Steel UNF Thread: ASTM F593 GP2 CW																
Seal Ring																	
DIN EN 61518 Type A								DIN EN 61518 Type B									
PA	PTFE							PB	PTFE								
GA	Graphite							GB	Graphite								
FA	O-Ring FPM (FKM by ASTM)																
Screw Length																	
UNF Thread								Metric Thread									
F25	1"							M25	25 mm								
F38	1 1/2"							M40	40 mm								
F44	1 3/4"							M45	45 mm								
F51	2"							M50	50 mm								
F70	2 3/4" (For Wafer Style Manifold c/w Oval Flange)																
F76	3" (For Rosemount 2051/3051 Coplanar™ Pressure Transmitter)																
Option																	
B	Cleaned for Oxygen Service (only for PTFE Seal Ring → Carbon filled PTFE)																



* IEC 61518 calls for the mentioned mechanical properties (for example B8 Class 2) because the flange connection is designed for high pressure service (up to 6,000 psi) and high temperature service. The usage of screws without the defined mechanical properties is critical and may lead to a sudden component failure which could cause a fatal accident!

Accessories – Pipe Plugs, Vent Valves, Adaptors

Vent Valves, Pipe Plugs and Pipe Fittings

Vent Valve
VS Type



Vent Valve
VT Type

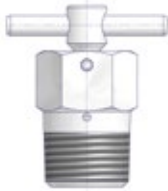

Pipe Plug
PP Type



Female to Male
Adaptor
FM Type



Hex Nipple
HN Type

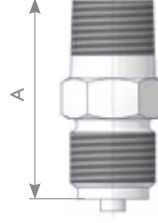

Thread Size	A (Available Lengths)				
	38.1 mm (1.50")	44.5 mm (1.75")	50.4 mm (2.00")	76.2 mm (3.00")	101.6 mm (4.00")
N2, G2	Standard		... L2.0		
N4, G4, M4			Standard	... L3.0	... L4.0
Combination of #2 and #4		Standard	... L2.0		

Ordering Information - Pipe Plugs and Vent Valves

				1	2	3	4	5	6	7	8	9	10
				V	S	M	S	-	N	4	-	M	
PP	Pipe Plug												
VS	Vent Valve with Bleed Screw												
VT	Vent Valve with T Handle												
Connection													
M	Male												
Material													
S	1.4401 / 1.4404 / 316 / 316L	F	Duplex UNS S31803	B	6Mo UNS S31254								
M	Alloy 400 UNS N04400	D	Super Duplex UNS S32750	T	Titanium Grade 2								
H	Alloy C-276 UNS N10276	V	Alloy 625 UNS N06625										
Threaded Connection													
N2	1/4 NPT												
N3	3/8 NPT												
N4	1/2 NPT												
Options - Specify in alphabetical order (digits first, then letters)													
B	Cleaned for Oxygen Service												
M	Wetted Parts with 3.1 certificate – Not applicable for Pipe Plug Type PP												

Wetted Parts according to a.m. material list are supplied according to NACE MR0175/MR0103 and ISO 15156 (latest issue) - except Titanium Grade 2

Ordering Information - Pipe Fittings

				1	2	3	4	5	6	7	8	9	10	11 - 16
				F	M	S	-	M	4	N	4	-	B	
FM	Female to Male Adaptor													
HN	Hex Nipple – Connections to be specified in alphabetical resp. ascending order. For example HNS-G4N4 (and not HNS-N4G4) resp. HNS-G2G4 (and not G4G2).													
Material														
S	1.4401 / 1.4404 / 316 / 316L	F	Duplex UNS S31803	B	6Mo UNS S31254									
M	Alloy 400 UNS N04400	D	Super Duplex UNS S32750	T	Titanium Grade 2									
H	Alloy C-276 UNS N10276	V	Alloy 625 UNS N06625											
Inlet - FM Type Female Thread														
Thread Type		Inch Size		Metric Size										
N	NPT	2	1/4	4	M20x1.5									
G	BSP Parallel (G) – EN 837-1	4	1/2											
M	Metric similar to EN 837-1													
Outlet														
Thread Type		Inch Size		Metric Size										
N	NPT	2	1/4	4	M20x1.5									
G	BSP Parallel (G) – EN 837-1	4	1/2											
M	Metric similar to EN 837-1													
Options - Specify in alphabetical order (digits first, then letters)														
B	Cleaned for Oxygen Service													
L#.	# → Available Lengths see table above – For Hex Nipples only													

Part according to a.m. material list is supplied according to NACE MR0175/MR0103 and ISO 15156 (latest issue) - except Titanium Grade 2.

Accessories – Swivel Gauge Adaptors

Swivel Gauge Adaptors

The Swivel Gauge Adaptors enable the easy positioning of the pressure instrument in any direction through 360°. The dimensions shown apply only to the illustrated components – if you need the dimensions for your individual type please contact the factory.

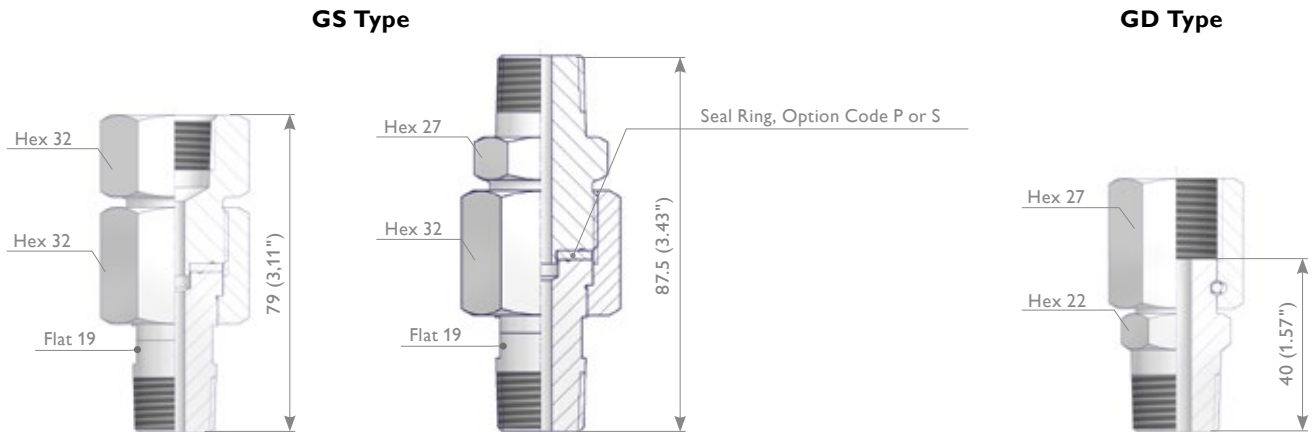

Ordering Information - Swivel Gauge Adaptors

		1	2	3	4	5	6	7	8	9	10	11	12	13	14	15	16
		G	S	-	M	M	S	P	-	N	4	N	4	-	B		
GS*	Swivel Gauge Adaptors – Screwed Design (10,000 psi / 689 bar)																
GD	Swivel Gauge Adaptors – Wire Design (6,092 psi / 420 bar)																
Inlet																	
M	Male	F		Female													
Outlet																	
M	Male	S		Swivel Nut (GD Type – G 1/2, Option Code G4 only)													
F	Female																
Material																	
S	1.4401 / 1.4404 / 316 / 316L	F		Duplex UNS S31803				B				6Mo UNS S31254					
M	Alloy 400 UNS N04400	D		Super Duplex UNS S32750				T				Titanium Grade 2					
H	Alloy C-276 UNS N10276	V		Alloy 625 UNS N06625													
Seal Ring																	
P	PTFE (GS Type only)																
S	Same Material as threaded components (GS Type only)																
A	No Seal Ring required (GD Type only)																
Inlet																	
Thread Type		Thread Size															
N	NPT	2	1/4														
G	BSP Parallel (G) – EN 837-1	4	1/2														
H	BSP Parallel (G) – DIN 3852 (GD Type only)																
Outlet																	
Thread Type		Thread Size															
N	NPT	2	1/4														
G	BSP Parallel (G) – EN 837-1	4	1/2														
Options - Specify in alphabetical order (digits first, then letters)																	
B	Cleaned for Oxygen Service																
M	Wetted Parts with 3.1 certificate																

* GS Type only: NPT Threaded Options as standard.

Wetted Parts according to a.m. material list are supplied according to NACE MR0175/MR0103 and ISO 15156 (latest issue) - except Titanium Grade 2.

Accessories – Oval Flanges, Anti-Tamper Key

Oval Flanges KF Type

Transmitter Interface EN 61518-A Code TD

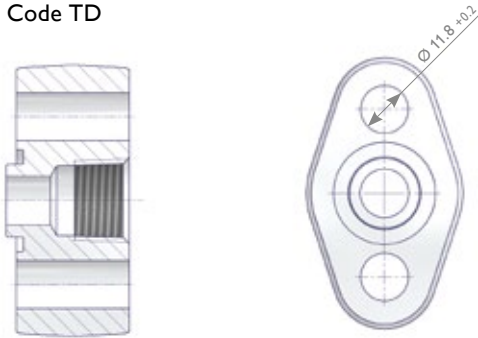

Transmitter Interface EN 61518 Code T4

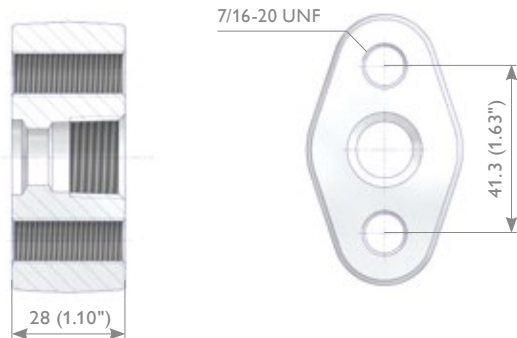

Ordering Information - Oval Flange (Kidney Flange, Futbol)

				1	2	3	4	5	6	7	8	9	10	11	12
				K	F	F	S	-	N	4	T	D	-	1	
KF	Oval Flange														
	Inlet														
F	Female														
	Material														
S	1.4401 / 1.4404 / 316 / 316L	F	Duplex UNS S31803	B	6Mo UNS S31254										
M	Alloy 400 UNS N04400	D	Super Duplex UNS S32750	T	Titanium Grade 2										
H	Alloy C-276 UNS N10276	V	Alloy 625 UNS N06625												
Material Option S as forging, all other materials made from flat bar															
	Inlet														
	Thread Type			Thread Size											
N	NPT	3	3/8												
H	BSP Parallel (G) – DIN 3852	4	1/2 (NPT Thread only)												
	Outlet (Flange Connection)														
TD	Transmitter Interface DIN EN 61518-A														
T4	Transmitter Interface DIN EN 61518														
	Options - Specify in alphabetical order (digits first, then letters)														
B	Cleaned for Oxygen Service (if ordered with Transmitter Mounting Kit – Only with PTFE Seal Ring available)														
	Accessory Kits for Oval Flange to Manifold/Transmitter mounting according to DIN EN 61518 – only applicable for Outlet Option TD and TE														
1	2 Hex Cap Screws 7/16-20 UNF, Carbon Steel ASTM A449 - Type 1, 1 PTFE Seal Ring														
2	2 Hex Cap Screws 7/16-20 UNF, Stainless Steel ASTM A193 B8M Cl.2, 1 PTFE Seal Ring														
3	2 Hex Cap Screws 7/16-20 UNF, Carbon Steel ASTM A449 - Type 1, 1 Graphite Seal Ring														
4	2 Hex Cap Screws 7/16-20 UNF, Stainless Steel ASTM A193 B8M Cl.2, 1 Graphite Seal Ring														

Wetted Parts according to a.m. material list are supplied according to NACE MR0175/MR0103 and ISO 15156 (latest issue) - except Titanium Grade 2.

Anti-Tamper Key ATK Type

ATK-ES Type



Check Valves

Check Valves CV Type

AS-Schneider Check Valves (Non-Return Valves) are designed for a cold (Working) Pressure rating of 10,000 psi (689 bar). The Check Valve allows flow in one direction only, closing when flow reverses. Should you still not find your option please contact the factory.

Features

- Soft Seated – O-Rings use-d are RGD (Rapid Gas Decompression) resistant
- Cracking Pressure: < 11 psi (0.75 bar)
- Re-Seal Pressure: < 20 psi (1.38 bar)
- Temperature Rating: -50°C up to +200°C (-58°F up to +392°F), depending on seal materials used
- 100% Pressure Tested – hydrostatically at 1.5 times the max. allowable (Working) Pressure (PS)
- Cv-Value: 0.3

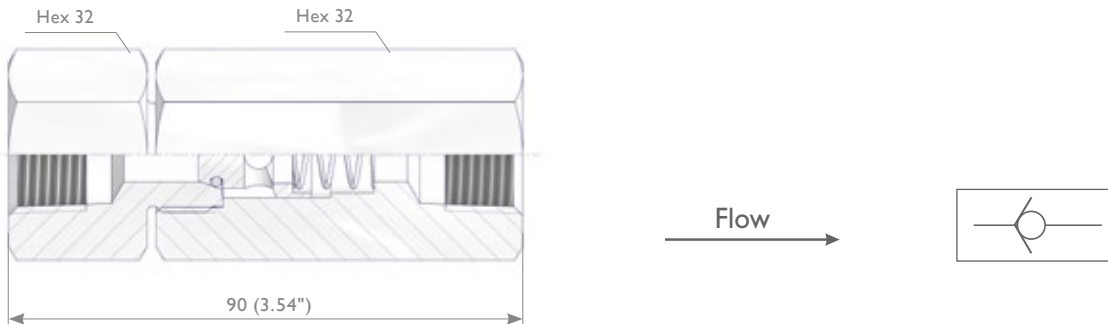

Ordering Information - Check Valves

	1	2	3	4	5	6	7	8	9	10	11	12	13	14
	C	V	F	F	S	K	-	N	4	N	4	-	M	
CV Check Valve														
Inlet														
M Male														
F Female														
Outlet														
F Female														
Material														
S 1.4401 / 1.4404 / 316 / 316L														
F Duplex UNS S31803														
M Alloy 400 UNS N04400														
D Super Duplex UNS S32750														
H Alloy C-276 UNS N10276														
V Alloy 625 UNS N06625														
B 6Mo UNS S31254														
T Titanium Grade 2														
Seal Ring														
K FKM – Fluorocarbon Rubber														
N HNBR – Hydrogenated Nitrile Butadiene Rubber														
P FFKM – Perfluorinated Rubber														
Inlet														
N2 1/4 NPT														
N4 1/2 NPT														
Outlet														
N2 1/4 NPT														
N4 1/2 NPT														
Options - Specify in alphabetical order (digits first, then letters)														
M Wetted Parts with 3.1 certificate														

Wetted Parts according to a.m. material list are supplied according to NACE MR0175/MR0103 and ISO 15156 (latest issue) - except Titanium Grade 2.
 Note: Check Valves which are not actuated for a period of time may initially crack at a higher pressure than above stated.

Complementary Products

In this catalogue the following products are not described in detail because they are covered in catalogue AS-0201:

Gauge Protectors

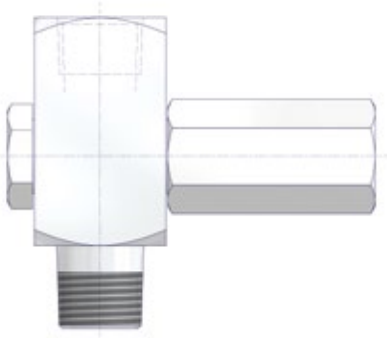

Gauge Snubbers



Compact Syphons

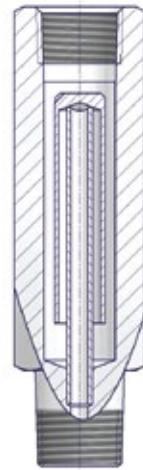

Coil Type Syphons / Pigtail Syphons

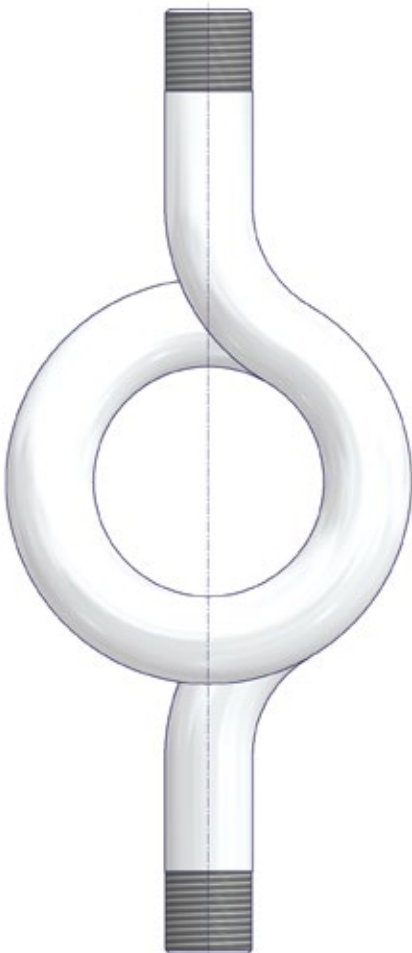

Elbows

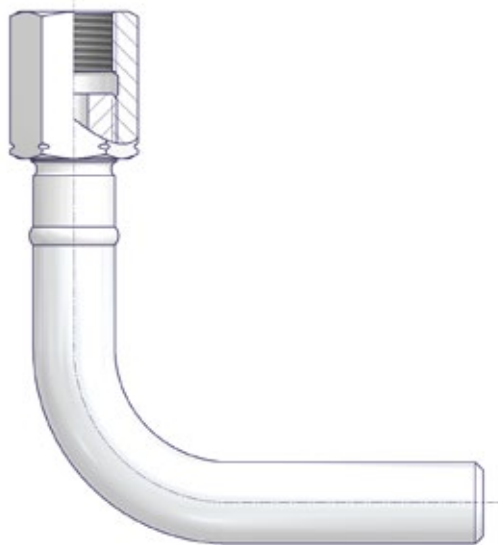

Technical Service Portal - Digital Valve Plate

Digital Valve Plate for Valves and Manifolds

The E Series Valves and Manifolds manufactured by the AS-Schneider Group are now marked with a unique QR-code. That QR-code provides easy access to static product information like material properties, certificates and physical dimensions via CAD drawings. It also includes operating and installation instructions or spare parts or replacement information.

Product Details



Operating Instructions



Individual Drawings



Spare Part Service



Technical Support



How it works

If you have an AS-Schneider valve or manifold with QR-code in your hand or installed in your plant, you can now access the product information very easy. The access is straightforward:



Maintenance Benefits

All technically relevant information on the product can always be retrieved directly.

Clear planning

More straightforward planning and installation via the mechanical properties of the product.

Error-free assembly

Automated error free equipment identification at the incoming good inspection and during the field installation.

Easy and fast maintenance

Easier and faster maintenance and repair cycles. This is possible due to direct access to spare parts or replacement units.

Link to asset management tool

Operators link this information into their respective asset and operation management system.

Environmental friendly

The environmentally responsible disassembly and disposal.

Check the DVP of your valves and manifolds:
www.qr4v.de

YOUR GLOBAL PARTNER

for Instrumentation and
Double Block & Bleed Valves



Visit us on:



ARMATURENFABRIK FRANZ SCHNEIDER GMBH + CO. KG
World Headquarters
Bahnhofplatz 12, 74226 Nordheim, Germany
Tel: +49 7133 101-0
www.as-schneider.com



ARMATURENFABRIK FRANZ SCHNEIDER SRL
Gradinari 32-38, 100404 Ploiesti
Romania
Tel: +40 244 384 963
www.as-schneider.ro



AS-SCHNEIDER ASIA-PACIFIC PTE. LTD.
970 Toa Payoh North, #02-12/14/15, Singapore 318992,
Singapore
Tel: +65 62 51 39 00
www.as-schneider.sg



AS-SCHNEIDER AMERICA, INC.
17449 Village Green Dr, Houston, TX 77040
United States of America
Tel: +1 281 760 1025
www.as-schneider.com



AS-SCHNEIDER MIDDLE EAST FZE
P.O. Box 18749, Dubai
United Arab Emirates
Tel: +971 4 880 85 75
www.as-schneider.ae



AS-SCHNEIDER INDIA PTE. LTD.
6/968U3 MN's Avenue, YMCA Calicut- 673001
Kerala, India
Tel: +91 999 544 2201
www.as-schneider.com

