



TURBO S.r.l.
Electronic Control Systems For Dust Collectors
e-mail: info@turbocontrols.it
web: www.turbocontrols.eu
TEL. ++39 (0)362 574024
FAX ++39 (0)362 574092

USER MANUAL FOR DIFFERENTIAL PRESSURE SWITCH E3T SERIES



05/05/2015
Manual Version 1.10
Hardware Version 1.00

General Description

Digital differential pressure switch used for the monitoring of differential pressure:

- ✧ in two different points of the pneumatic line
- ✧ between the clean chamber and dirty chamber of dust filters (vacuum system)
- ✧ between the dirty chamber of the dust filters and the environment (pressurised system)

When the suction filter is activated, the instrument releases an electrical alarm contact on two relays. One relay signals the desired filter clogging threshold (Marx. dP alarm) and the other signals when the pressure is below the filter design data, which could be caused by a break or damage in one or more filtering elements (Min. dP alarm).

Technical features

Container

- ABS base and polycarbonate lid.
- IP65 degree of water and dust protection (EN60529).
- Impact résistance IK08/07 2 Joule (EN62262).

Device Performance

- Dedicated software program, managed by microprocessor that is easy to configure and consult and facilitates the use of the instrument even by unskilled users.
- 115-230 Vac 50-60 Hz (standard) and 24 Vac/Vdc (optional) voltage supply.
- 3 x 0.8 inch digit 7-segment LED display.
- Two alarm relays.
- SD memory card to save data. The card can be extracted for consultation and saving of the data log. Sampling is executed every 10 seconds.
- 4-20mA output for remote metering of the differential pressure.
- Hour meter.
- Pressure is measured in kPa, (WC inches optional).
- Maximum dP alarm (clogged filter) with the possibility of inclusion/exclusion.
- Minimum dP alarm (broken sleeve/cartridge) with the possibility of inclusion/exclusion.
- Setting of current date and time associated with data log storage on the SD card.

Electrical Features

Power Supply:

- ✧ 115 VAC \pm 10% 50-60 Hz – 6W
- ✧ 230 VAC \pm 10% 50-60 Hz – 6W
- ✧ 24 VAC \pm 10% 50-60 Hz – 6W optional
- ✧ 24 VDC \pm 10% – 6W optional

Warning! Read the section on installation before connecting the device.



Galvanically Isolated Outputs:

- ✧ 4 – 20mA (remote dP metering)

Alarm Relays:

The two alarm relays have 2 clean contacts to terminals 4-5 and 6-7.
Maximum permissible load: 3A @ 250Vac, 2A @ 24Vac, 2A @ 24Vdc

Fuses

1 x 315mA

Operating Temperature

-10°C ÷ +55°C

Storage Temperature

-20°C ÷ +60°C

Differential Pressure Meter

Measurable pressure range: 0/10 kPa.

Warning! Higher pressures will damage the device.
Do not connect clogging measuring tubes to the compressed air circuit.





Upon request the maximum full scale measure may be limited to:

- 0 – 1 kPa 0 - 4 inch WC
- 1 – 3 kPa 4 - 12 inch WC
- 2 – 5 kPa 8 - 20 inch WC
- 3 – 7 kPa 12 - 28 inch WC
- 4 – 10 kPa 16 - 40 inch WC



Maximum Pressure Applicable: 70 kPa – 0.7 bar – 298 inch WC

Warning Symbols Used In This Manual

The information regarding safety are highlighted using the symbols:

	Warning-Danger	Generic - Warning-
	Risk – Danger	Electric Current
	Dispose according to the standards for electrical and electronic equipment RAAE	

Installation Rules Notes and Warnings

- ⇒ Protect the device from direct exposure to sunlight.
- ⇒ Do not position the device near or directly in contact with sources of heat or electromagnetic fields. 
- ⇒ Fix the device of a height of at least 60 cm from the ground. In a clearly visible place easily accessible.
- ⇒ Connect the device to power lines other than those for operating motors or other large power devices which could generate network interference or instability.
- ⇒ The electrical supply of the unit must be protected by a differential switch 230Vac~ 30mA and a bipolar magneto thermic 230Vac~ 10A, positioned in a place easily accessible.
- ⇒ Before working on the equipment to perform any operation switch off the magneto thermic differential switch. 
- ⇒ For electric operations, always remove voltage, wait 30 seconds for the inside capacitors to discharge before opening. At the end of the operations, close the device to restore the correct degree of protection before powering up.
- ⇒ For the connection of the supply voltage, use anti-flame wires with a minimum section of 0.75mm² certified and conform to the standard IEC60227 or IEC60245.
- ⇒ Use flame-retardant cables with a minimum cross-section area of 0.75 mm² for all control signals.
- ⇒ Use flame-retardant cables with a minimum cross-section area of 0.75 mm² to connect to the indicating relays.
- ⇒ The wire ground conductor of protection must be yellow/green.
- ⇒ The wire ground conductor of protection must be connected first.
- ⇒ The wire which is colored yellow/green must only be used for the ground conductor.

- ⇒ The cable glands must be chosen according to the diameter of the cable to be used.
- ⇒ The sealing of the press cable is guaranteed by the compression of the rubber gasket that tightens on the outer diameter of the cable.
- ⇒ The tightness of the cable gland is guaranteed by the compression of the rubber seal that tightens on the outer diameter of the cable.
- ⇒ The size of cable and cable gland must ensure that a power cord traction is not acting on the terminals.
- ⇒ The terminal block must not be the point of mechanical anchoring of the conductors.
- ⇒ The cable gland PG9 supplied on request, has cable diameter minimum of 4mm and a maximum of 8mm, with clamping nut by 19mm.
- ⇒ Any use not described in this user instruction manual or incorrect use of the device may cause damage to the device or to the devices connected to it.
- ⇒ Furthermore, incorrect use or tampering with the device may cause injury.
- ⇒ Waterproofness of the casing is guaranteed when the flap is closed.
- ⇒ Make sure that rigid or flexible ducts used for wiring, if any, do not fill up with water or other liquids.
- ⇒ Do not make holes not protected on the container or protected by accessories with protection degree lower than that of the housing of the control unit.
- ⇒ Cut off power supply immediately if water is found in the casing.
- ⇒ If the control unit is used in ways not specified by the manufacturer, the protection provided by the device may be impaired.
- ⇒ The Control Unit does not release potentially toxic or harmful substances to the health and the environment.
- ⇒ No part with dangerous voltage is normally accessible.

Do not use the pressure switch before reading and understanding this manual.

Display And Keyboard

The front panel has 4 circular buttons to control the equipment. They are shown as an image when the display is turned on.

- The SET button enables to enter and exit the programming menu.
- The + and - buttons enable to scroll functions F01 to F06. After entering one of the F0_ functions, use the OK button to increase or decrease the values.
- The OK button is used to confirm data and reset alarms.
- If the + button is pressed during ordinary operation, the activity hour meter is displayed.
- If the SD Card is inserted, the pressing of the OK button enables safe removal of the card.

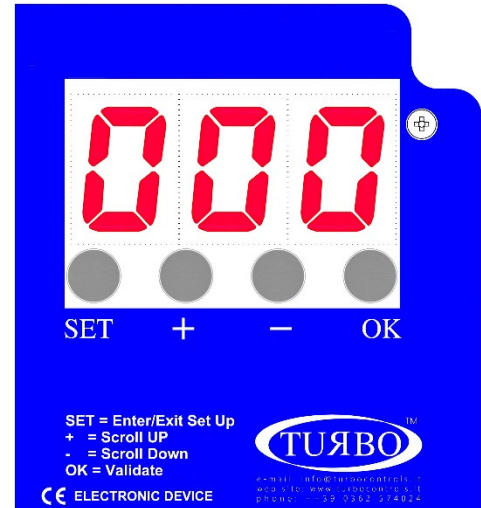

Menu Layout

- Press SET
- Scroll the functions with the + and - buttons.
- Confirm the selected function using the OK button.
- Increase or decrease the parameter value using the + and - buttons.
- Confirm and exit using the OK button.
- The programming mode can be exited by pressing the SET button again.



List of Functions

F. No.	Name Function	Description	Min. Value	Max. Value	Values Set
F01	Alarm Mode	Alarm mode: 0 – Alarms disabled on relay 2. 1 – Only the minimum threshold alarm is enabled on relay 2. 2 – Only the maximum threshold alarm is enabled on relay 1. 3 – Maximum and minimum threshold alarms enabled on the 2 relays.	0	3	2
F02	Zero dP	dP kPa sensor calibration value	kPa 0.00 Inch WC 0.00	kPa 2.55 Inch WC 10.20	kPa 0.75 Inch WC 3.00
F03	Minimum dP Threshold Alarm	dP kPa low alarm threshold value	kPa 0.00 Inch WC 0.00	kPa 9.99 Inch WC 39.90	kPa 1.00 Inch WC 4.00
F04	Maximum dP Threshold Alarm	dP kPa high alarm threshold value	kPa 0.00 Inch WC 0.00	kPa 9.99 Inch WC 39.90	kPa 3.00 Inch WC 12.00
F05	Set Date	Sets the date on the system in the dd-mm-yy format dd = day 1 – 31 d mm = month 1 – 12 n yy = year 0 – 99 y	1 1 00	31 12 99	01 01 14
F06	Set Time	Sets the time on the system in the hh-mm format hh = hour 0 – 23 h mm = min 0 – 59 n	0 0	23 59	00 00
F07	threshold for fan	dP threshold for fan on recognition	kPa 0.00 Inch WC 0.00	kPa 9.99 Inch WC 39.90	kPa 0.10 Inch WC 0.40

Exit the programming and press the + button to consult the hour meter.

Alarms

The control unit performs a series of checks during the ignition cycle and normal operation.

Below is a description of possible alarms and relative solutions.

Alarm No.	Description	Operation
E01	dP minimum threshold alarm	
E02	dP maximum threshold alarm	
E04	Hardware dP maximum alarm (dP > 98% full scale = 9.80 kPa)	The system pressure is high, beyond the instruments metering ability
E08	Internal clock error	Replace buffer battery (CR1632 3V 130mAh) and set current time and date
E16	Zero dP out of range error	F02 out of scale
E61	SD Card not formatted or not working. Resettable with OK while viewing the error code	
E62	SD Card: insufficient free space. Resettable with OK while viewing the error code	Check memory card, free up space or format
E64	SD Card is write protected. Resettable with OK while viewing the error code	Move the WP button, found on the side of the memory card, from the safety position

Operation Description

When the pressure switch is powered, the display shows the SW version installed and then the detected dP value.

Zero dP calibration

This function enables to reset the dP metering with the fan turned off.

Use the + and - to increase or decrease the value shown as desired. This value will be subtracted from the value read by the dP sensor.

Self-Calibration of the dP Sensor.

This function enables to automatically reset the dP metering with the fan turned off.

With the device turned off, press and hold down the "SET" and "OK" buttons at the same time and then turn the device on. After the ignition test, "CAL" will appear. Release the buttons. After a few seconds, the control unit will return to the normal state. Automatic calibration has been completed.

Fuses

Fuse F1, which can be restored in case of need, is located on the left of the power supply terminal in correspondence with the input voltage connection. The fuse is 315mA 5x20mm.

SD Memory Card

The SD memory card slot is located on the bottom right of the control unit under the polycarbonate lid.

The card is not supplied with the control unit.

A card with a maximum of 32GB can be used.

The card must be formatted FAT32, which is the format recognized by all devices and operating systems.

Before removing the memory card, press the OK button with the control unit on, wait for the cd (card) indication and the alternating flashing of the horizontal lines of the third figure ≡. The card can now be safely removed.

The SD Card connector is push-pull.

Press upwards and extract the card to remove it.

Connection Diagram

24 VDC / 24 VAC Version

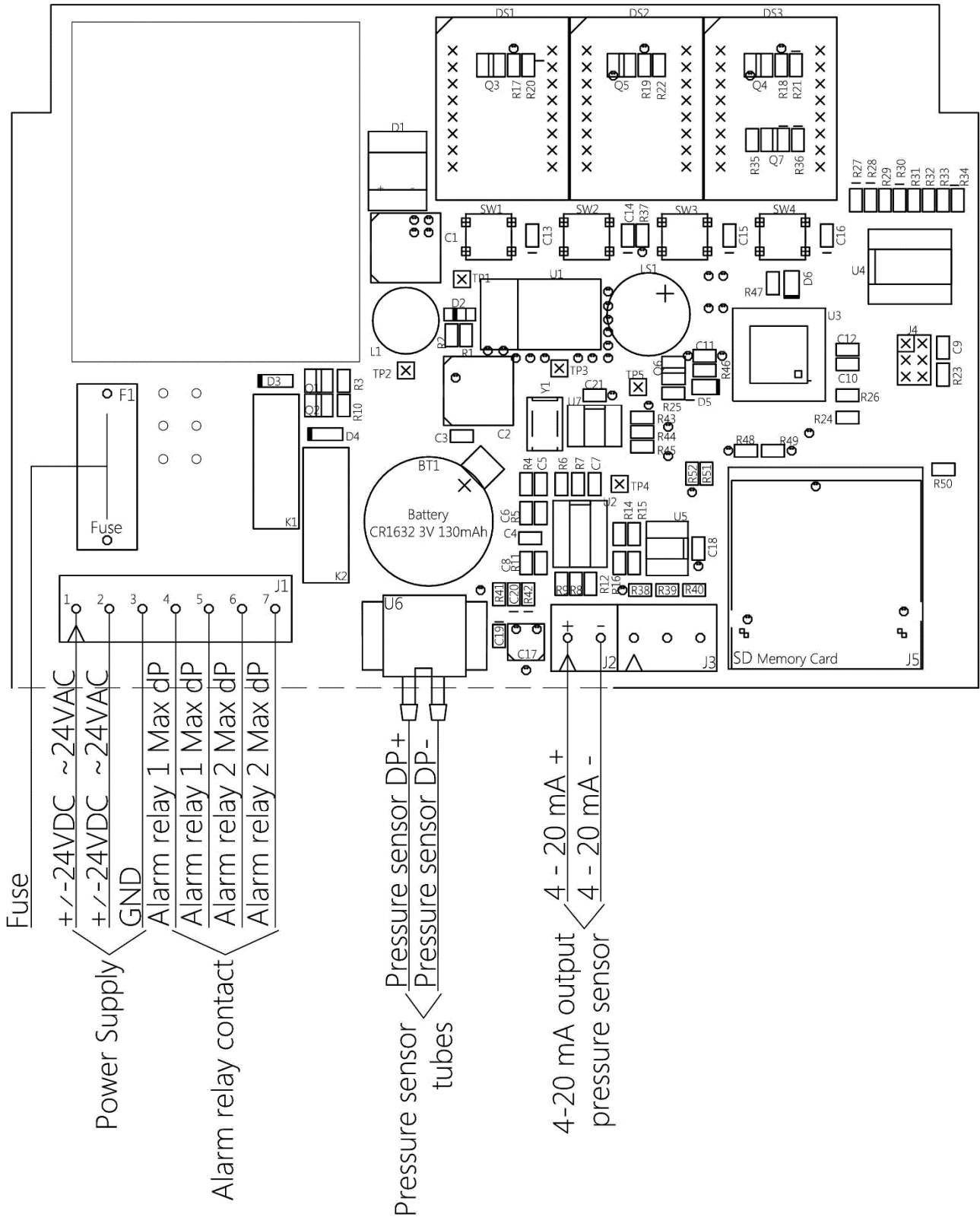

Pressure Sensor	dP + Pressure inlet dirty section
	dP - Depression inlet clean section

115 / 230 VAC version

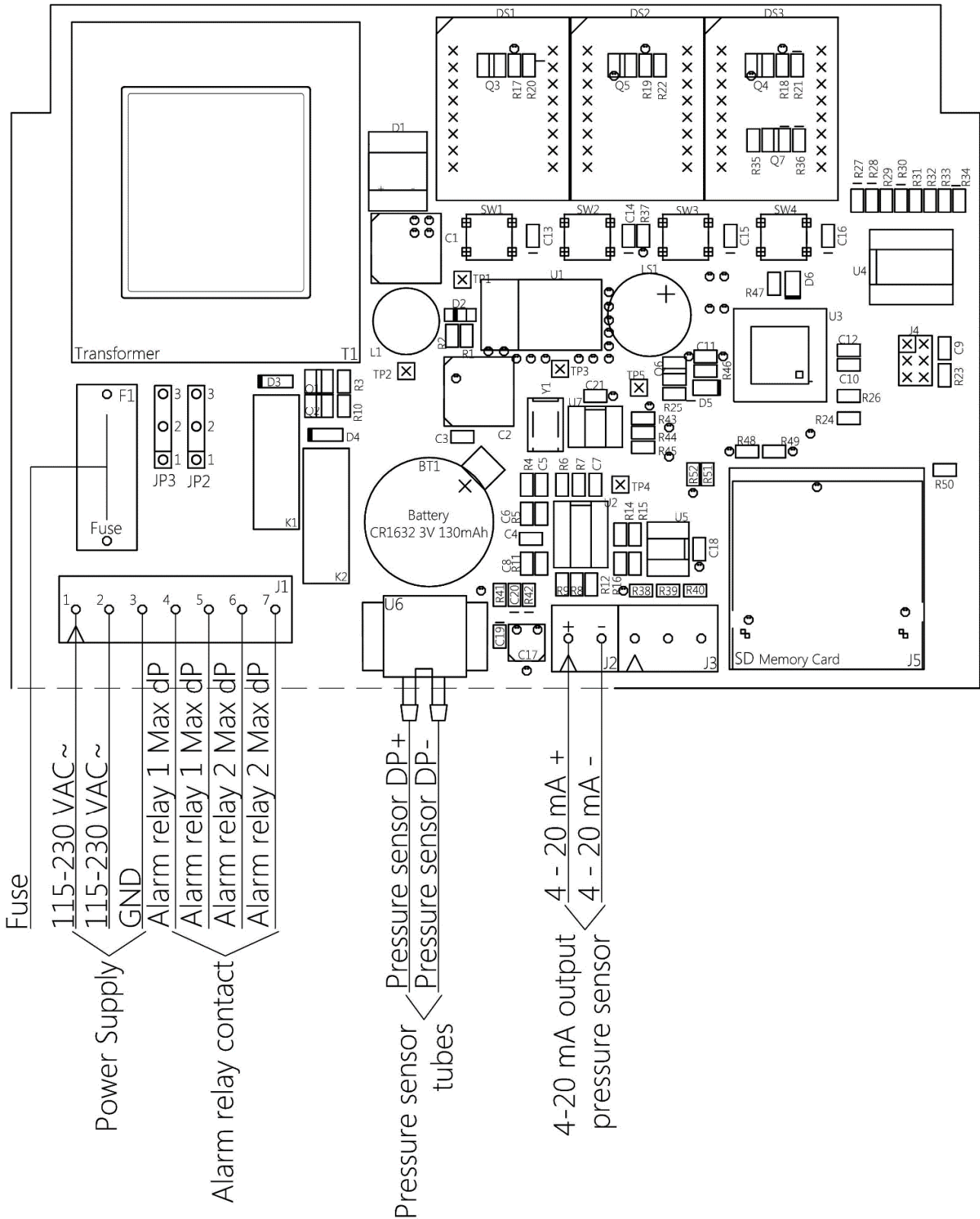

Pressure Sensor	dp + Pressure inlet dirty section
	dp - Depression inlet clean section

Configuration of 115 / 230VAC jumpers

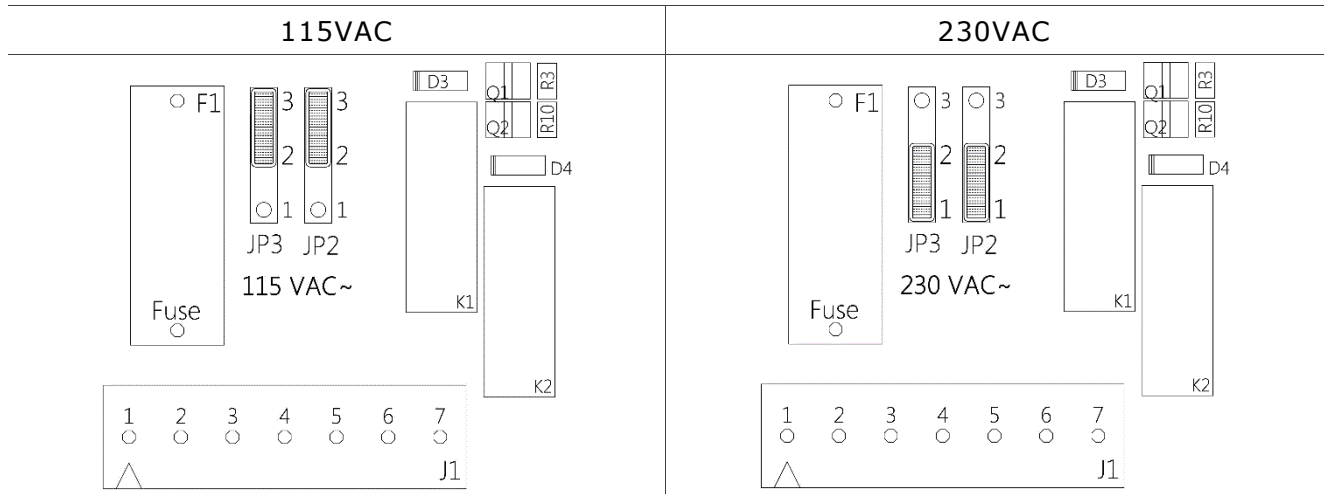

Installation And Dimensions

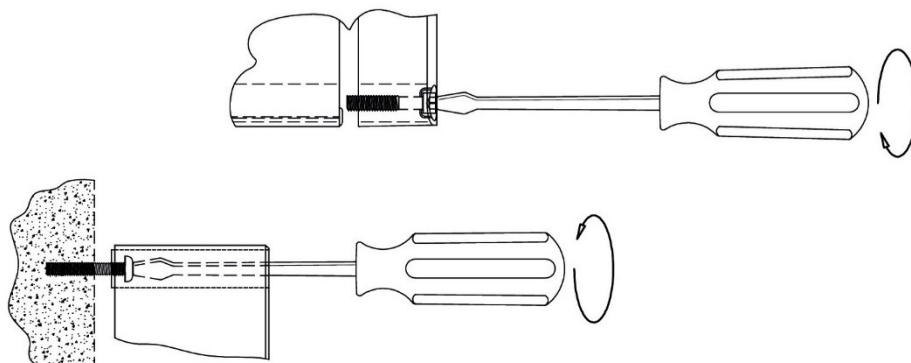
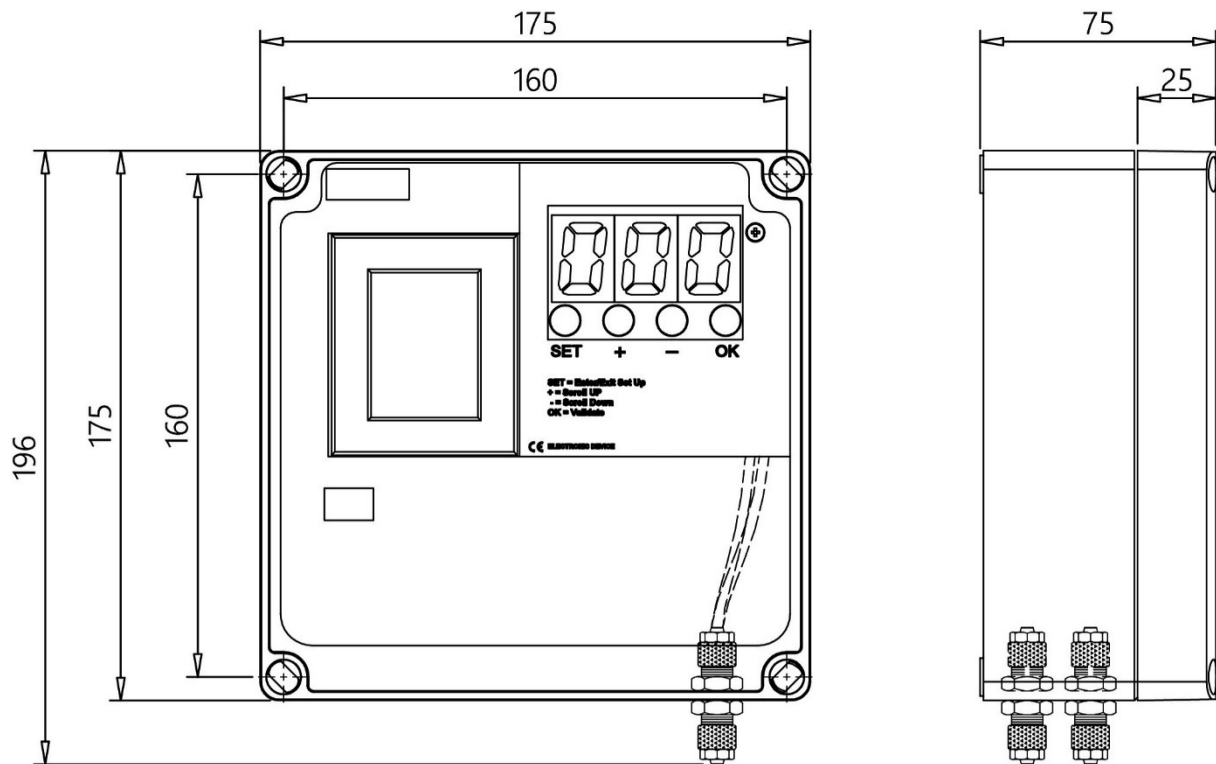

Maintenance

Only the fuses, batteries and SD card can be replaced.
All other repairs must be done by the manufacturer.

Disposal

Do not disperse in the environment after use. Dispose of the product according to current regulations for the disposal of electronic equipment.



This device is used in a dust collector system and, therefore, it is part of a fixed installation.

Warranty

The warranty has a duration of 2 years. The company will replace any electronic component deemed defective exclusively at our workshop, except in the presence of contrary agreements to be authorized by the company.

Exclusions From Warranty

The warranty is void in the case of:

- Signs of tampering and unauthorised repairs.
- Incorrect use of the equipment that does not comply with the technical data.
- Incorrect electrical connections.
- Failure to comply with the installation standards.
- Use beyond EC standards.
- Atmospheric events (lightning, electrostatic discharge), over voltages.
- Clogged air connections. Damaged tubes.

Troubleshooting FAQ

Fault	Possible Cause	Solution
The display does not turn on.	Supply voltage not present. Blown fuse.	Check that the supply voltage is present and concordant with that required for the equipment (terminals 1, 2 and 3). Check the protection fuse on the power supply.
Differential pressure metering is not correct.	Clogged air connections. Damaged tubes.	Check that differential pressure metering is 0.00 kPa when the tubes are disconnected. In that case, check that the connection tubes between the equipment and the filter are not clogged or damaged.
Alarm messages appear.		Check the alarm code against the table.
The alarms do not activate the signalling devices.	Errors in the wiring. Lack of powering of the alarm devices.	The alarm devices must be powered by voltage external to the differential pressure. To activate them, the latter opens the relative relay.
Random and accidental shut downs and reboots will reset the power switch.	Check that there is not an unfiltered pulse load (punching machines, welders, plasma cutters, etc.) on the power line.	If necessary, install a filter on the differential pressure power line.



The Manufacturers' Declaration Of Conformity

Name of the Manufacturer

TURBO Srl

Address of the Manufacturer

Via Po 33/35 20811 Cesano Maderno Italy

Declares that the product

Product Name

E3T differential pressure switch

Product Options

All

Complies with the following directives:

Directive 2014/30/EU Electromagnetic Compatibility compliant with Harmonised European standards EN61000-6-2:2005 class B of EN61000-6-4:2001

Directive 2014/35/EU Low Voltage compliant with Harmonised European Standards EN 60947-1:2004

A typical configuration of the product was tested.

Cesano Maderno, 05/05/2015

F. MESSINA (C.E.O.)

TURBO Srl

Code And Serial Number