

Charge Displacement Probe E9TRB

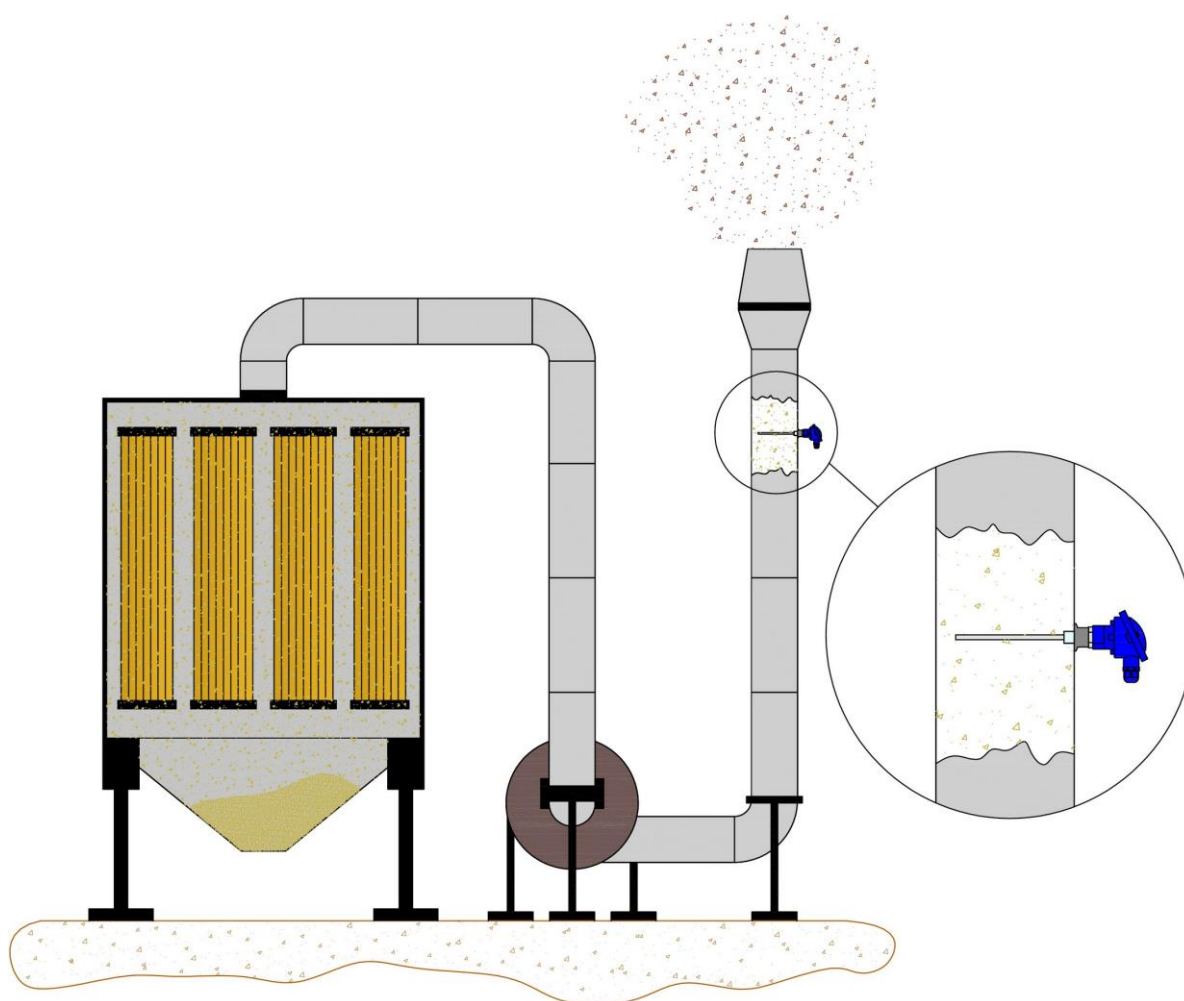

Use And Maintenance Instruction

Description	3
Operating Principle	3
Table Of Available Versions	4
Output 4 ÷ 20 mA	5
Serial Output RS485	5
Installation	5
Accessories	9
Terminals Connections Layout	9
Startup	11
Output Status And Functionality	11
Self-Acquisition	12
Test Procedure	12
Electrical Connections	13
Technical Features	15
Maintenance	15
Warnings	15

Description

The charge displacement probe is a microprocessor-based instrument, pre-calibrated, complete with two digital outputs optically isolated open collector type, a RS485 serial interface to configure and / or download the data, an output $4 \div 20$ mA and a set of LEDs for synthetic indications of operation modes.

The probe is designed to detect and measure dust emissions caused by breakage of bag filters.

There are no limitations in installations due to different types of powders.

Operating Principle

The charge displacement probe uses the principle of the displacement of the electric charge in the electrode, induced by the electrical charges, carried by dust immersed in a gaseous fluid.

The amount of electric charge dynamically induced on the electrode is proportional to the amount of dust present in the gaseous fluid.

An increase in the concentration of dust causes a proportional increase of the signal that reaches the microprocessor.

Applying mathematical algorithms, the individual powder particles are counted to be able to calculate their concentration in milligrams per cubic meter.

The computed values can be stored internally in order to be drafted in the future, or sent via RS485 serial transmission, or $4 \div 20$ mA to an external control unit for further analysis and / or views.

Table Of Available Versions

	Versione			
	E9TRB005	E9TRB006	E9TRB008	E9TRB009
Description	TRIBO PROBE 3/4" GAS RS485 4-20MA	TRIBO PROBE 3/4" GAS RS485 4-20MA	TRIBO PROBE 3/4" GAS RS485 TEFLON INSULATION PTFE	TRIBO PROBE 3/4" GAS RS485 HOT EXHAUST FUMES TEMPERATURE <220°C
Input voltage	20 ÷ 30Vdc			
Power	1 W			
Sensitivity Accuracy	0,1 mg/m ³	0,01 mg/m ³	0,1 mg/m ³	0,1 mg/m ³
Granulometry	> 0,3 µm			
Working pressure	<2 bar			
Temperature of the fluid	<140°C	<140°C	<220°C	<220°C
Working temperature for electronic components	-20°C ÷ +60°C			
Minimum speed of the fluid for the measuring	>4m/s			
Threshold 1*	5 mg/m ³	1 mg/m ³	5 mg/m ³	5 mg/m ³
Threshold 2*	10 mg/m ³	2 mg/m ³	10 mg/m ³	10 mg/m ³
Output 4 ÷ 20 mA	SI (max load=500 Ω)	SI (max load=500 Ω)	SI (max load=500 Ω)	SI (max load=500 Ω)
Self Acquisition	NO	NO	NO	NO
Dedicated RS485 port	SI			
Enclosure material	Alluminio			
Electrode material	Stainless steel AISI 304 ø 8mm	Stainless steel AISI 304 ø 8mm	Stainless steel AISI 304 ø 8mm PTFE insulation ø 20mm	Stainless steel AISI 304 ø 8mm
IP protection	65			
ATEX certification	On request ATEX II 3D EEx IP65 T85 °C			
Application	The probe is designed to detect and measure dust emissions caused by breaking of bag filters.	The probe is designed to detect and measure dust emissions caused by breaking of bag filters with a lower fault threshold	<ul style="list-style-type: none"> Fluid with relevant concentrations of oils (example: machining plants and industries) Fluid with high concentration of moisture Aspiration plant where it isn't provided a chimney and the electrode is exposed directly to the rain Fluid temperature <220°C 	The probe is designed to detect and measure dust emissions caused by breaking of bag filters with a fluid temperature lower than 220°C

* If using self-acquisition function, the values (in mg/m³) of threshold 1 and threshold 2 do not match to this table.

Output 4 ÷ 20 mA

The switch J1 defines the type of the range only for the output 4 ÷ 20 mA.

With J1 open, the full scale value (20 mA) will be achieved with a dust concentration of 10 mg/m³ or equal to 2 mg/m³ for probe E9TRB006.

With J1 closed, the full scale value (20 mA) will be achieved with a dust concentration of 50 mg/m³ or 10 mg/m³ for probe E9TRB006.

Serial Output RS485

The RS485 serial interface allows the transfer of data between the probe and other equipment, manufactured by Turbo s.r.l., which detect the signals generated by the probe.

Installation

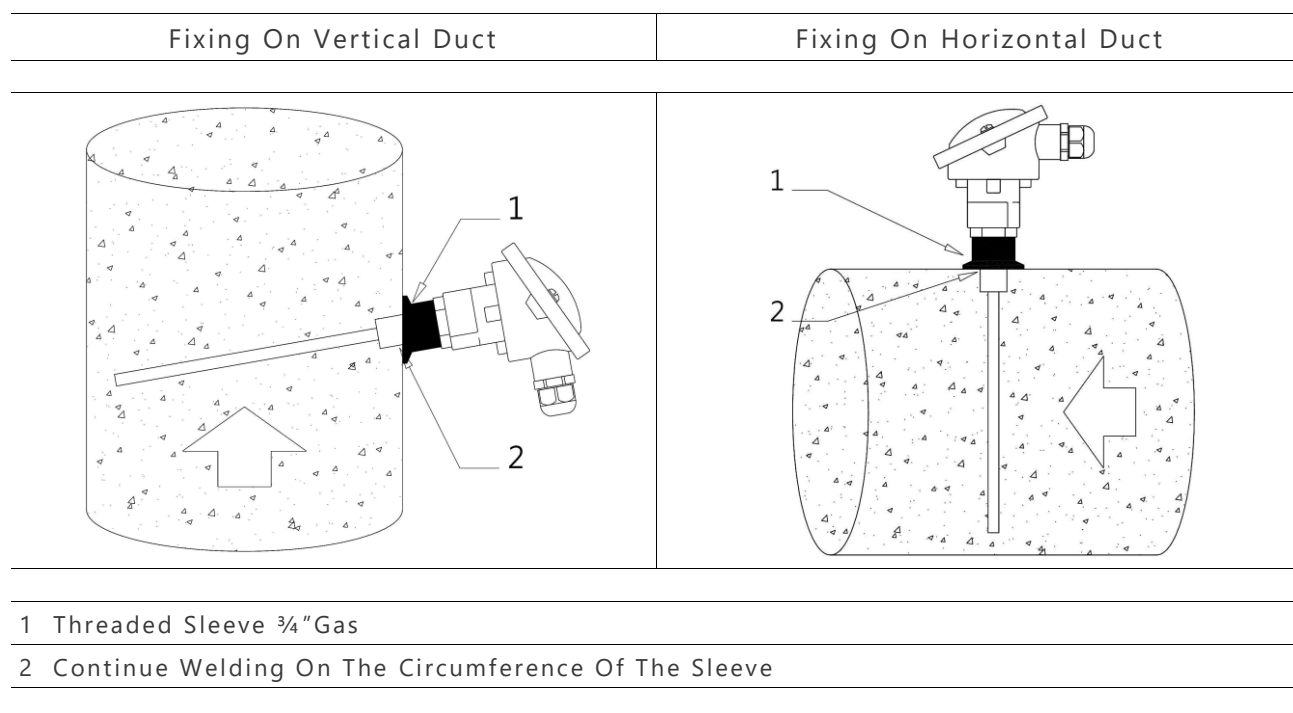

- The triboelectric probe must be installed on a metallic duct electrically connected to the ground, so as to ensure shielding from electromagnetic noise.
- The probe must be away from obstacles such as valves, chokes, bends which can disturb laminar air motion, change the uniform concentration of dust, both upstream and downstream of the probe, the distance is at least 5 times the diameter of the pipe.
- The probe should be protected from direct sunlight.
- Must be fitted with a slight tilt angle, the sensitive rod downwards, so as to facilitate the fall of drops of condensation, prevent fluid retention on the electrode.
- In the figure of mounting on vertical duct, the inclination is represented in an excessive way than necessary which are few degrees 1° to 3°, for the sake of clarity.

View Entire Conduct

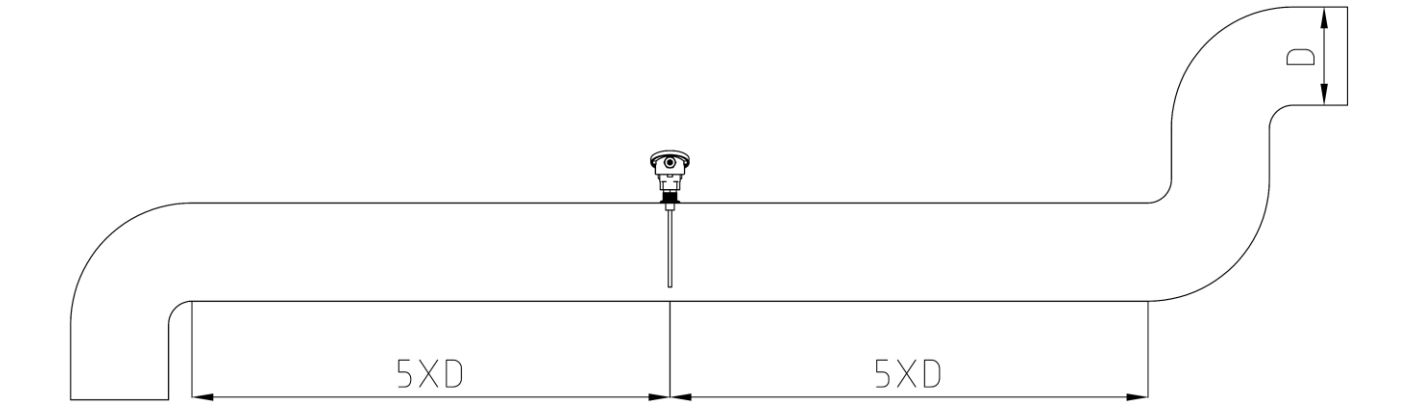

Inner Duct View

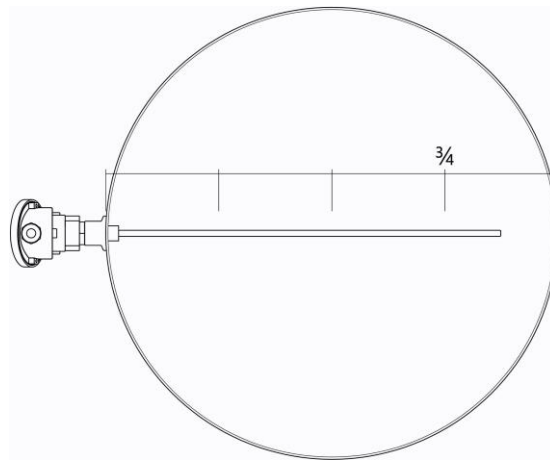

For proper measurement of powders, the measuring electrode of the probe must exceed $\frac{3}{4}$ of the diameter of the pipe.

In order to minimize any dust deposits on the electrode is not recommended mounting the probe with the enclosure underneath the pipeline.

The electrode must have a length slightly less than the diameter of the pipe it must not touch the pipe or other metal objects and / or blocking.

Please note, that the quality of the signal is always proportional to the amount of air / powder mixture that invests the electrode.

After determining the location of the installation, screw the probe into the conduct, by interposing an adapter $\frac{3}{4}G$ and without force.

Dimensions

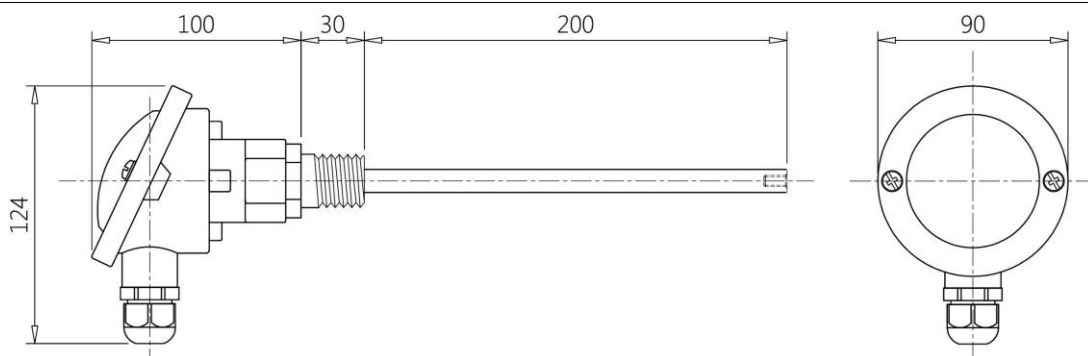

Installation Of The Probe On Discharge Duct For Different Exhaust Fumes Temperatures

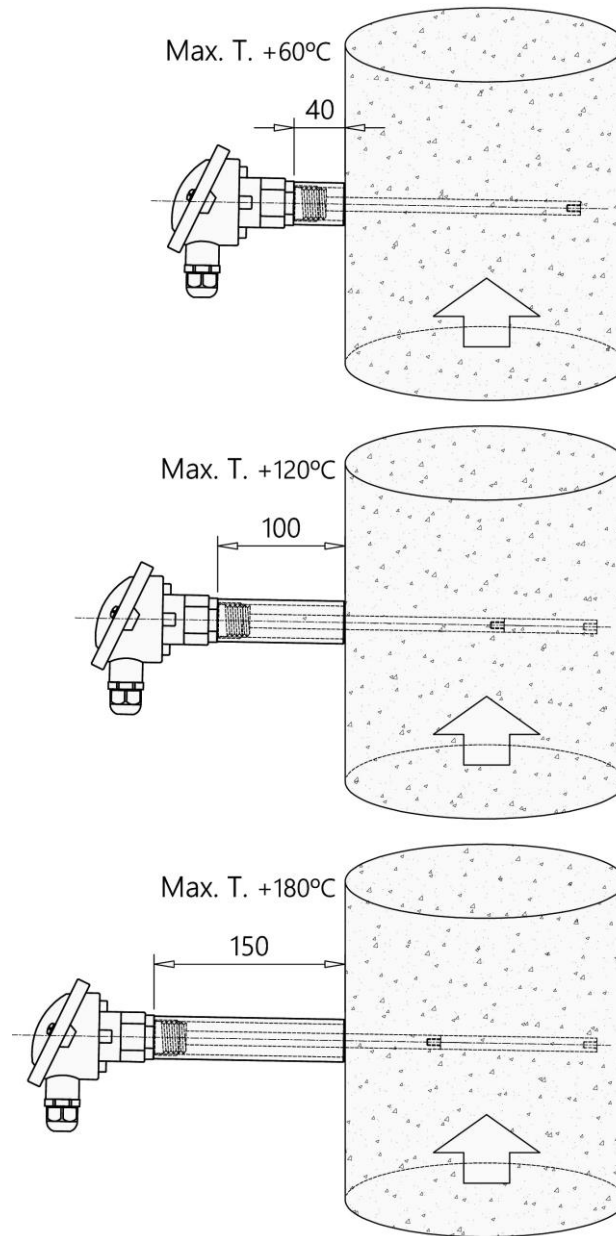

Fumes Temperatures	Part Number	Description
$\leq + 60 \text{ }^{\circ}\text{C}$	3201058	Threaded Sleeve F. 3/4"G L040
$\leq + 120 \text{ }^{\circ}\text{C}$	3201060	Threaded Sleeve F. 3/4"G L100
$\leq + 180 \text{ }^{\circ}\text{C}$	3201062	Threaded Sleeve F. 3/4"G L150

Probe Installation With Long Stem And Stem Isolated Version

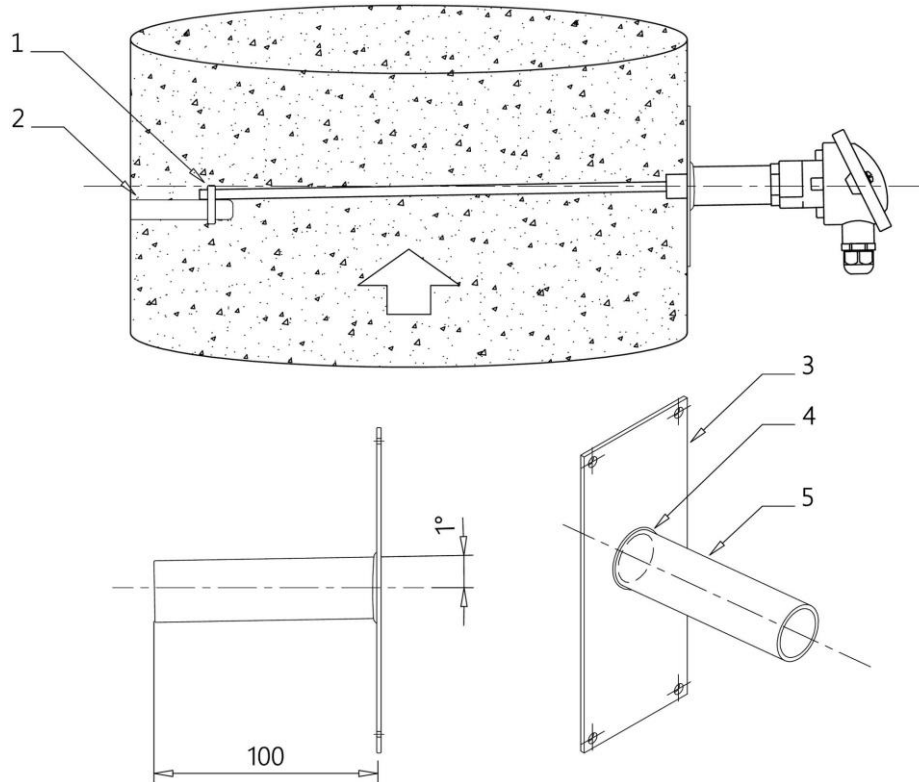



- 1 Collar For The Fastening Of The Electrode
- 2 Support For Probe Electrode Made Of Teflon To Fix On The Conduct
- 3 Support For Probe With Sleeve To Be Fixed On The Conduct
- 4 Continuous Welding On Sleeve Circumference
- 5 $\frac{3}{4}$ "Gas Threaded Sleeve

Support the electrode of the probe in the longer versions of 500 mm, as described in the assembly drawing, it is recommended to avoid damage and breakages.

The support for the electrode must be made in material plastic insulating, the electrode does not be in contact with metallic parts that alter the measurements.

Accessories

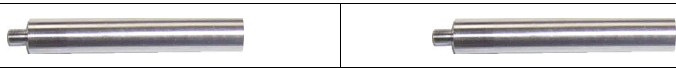
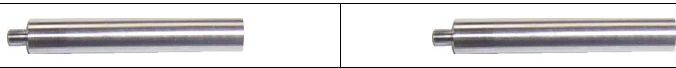
Extensions And Adaptations For Electrode Installation On Pipelines Of Various Diameters

	Length	50 mm 100 mm 200 mm 400 mm
	Thread	M4 m 10 mm
	Material	Inox Steel d. 8 mm
		

The extensions of the electrodes must be joined together using a medium strength thread locker to prevent loosening due to vibration, shock and temperature fluctuations.

Terminals Connections Layout

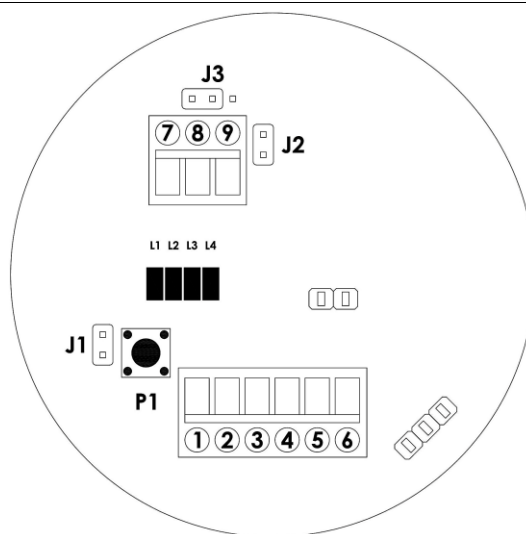

Led Description:

- L1 : ON = +V voltage s present.
- L2 : ON = warm up / self-acquisition / serial switching.
- L3 : ON = output U1 ON (pin 7) irregular flashing.
- L4 : ON = output U2 ON (pin 8).
- L2 + L3 : flashing = probe vitality (probe ON).
- L2: irregular flashing = serial connection activated.

Jumpers Description:

J1 : Operation range only for 4 ÷ 20 mA output.

- J1 open = full scale (20 mA) at 10 mg/m³ or 2 mg/m³ for probe E9TRB006.
- J1 closed = full scale (20 mA) at 50 mg/m³ or 10 mg/m³ for probe E9TRB006.

J2 : inversion of outputs logic.

- With J2 open, output contacts (solid state relay) normally open,
- With J2 closed, output contacts (solid state relay) normally closed.

J3 : setting common to the positive / negative (see connection example 1).

Button Description:

- P1 : button to self-acquisition (if provided).

Terminals Description:

- 1 = Positive Input Power Supply
- 2 = Negative Input Power Supply
- 3 = Test Input For Probe Operation Check
- 4 = Serial Rs485 (A) [only for Turbo control unit]
- 5 = Serial Rs485 (B) [only for Turbo control unit]
- 6 = Output Signal Pwm 4/20 mA
- 7 = Output Threshold U1
- 8 = Output Threshold U2
- 9 = Fault Output U3

Analog connection 4-20 mA:

Example of analog connection to a control unit for reading and managing the tribo probe. Use a cable with shielding braid which will then be connected with a screw to the metal conduct of exhaust fume.

NOTE: The digital connection is only possible with the Turbo s.r.l. production control units.

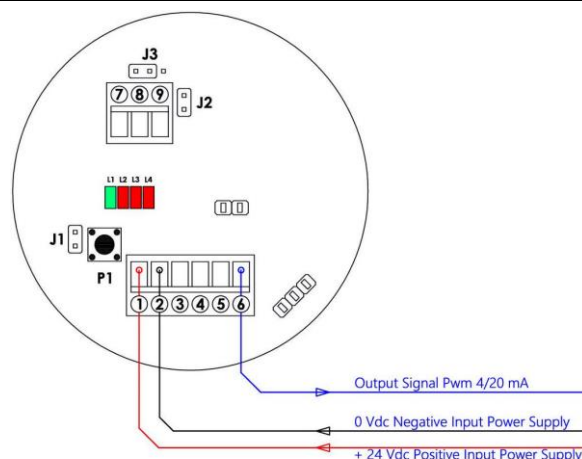

Startup

After powering up the probe and verified the green led L1, it is necessary to wait for a warm-up time of 3 minutes, during which the probe is measuring but the outputs are disabled.

After this period of time, if the jumper J1 is left OFF, disengaged, the probe will operate in manual mode with preset thresholds from the default settings.

If the jumper J1 is inserted, the probe will work with thresholds set automatically. in this condition, the probe will wait for the press of the button P1, this state will be indicated by the led L2 mode "a" that is slowly blinking.

To start the self-acquisition: hold down P1 button for 5 seconds, the led will light steadily L2 (mode "b"), and wait until the led turned off after about 4 minutes, at this point the acquisition will be completed and the values will be stored in a solid-state memory, which will keep them even if the probe will be de-energized.

N.B. values are, obtained for the probe, the reference for the activation of the outputs, then be understood as operating values with "regular" quantity of dust, so it is recommended to perform the self-acquisition by choosing the moment considered most suitable during processing .

If you want to store new values (eg. changes of working conditions), run new self-acquisition by pressing P1 as described above.

Output Status And Functionality

Status

▫ Alarm 1

Output U1 On = exceeded during the normal measure of the factory value (see table) or the self acquired multiplied 5 times (multiplication factor x 5).

▫ Alarm 2

▫ Output U2 On = exceeded during the normal measure of the factory value (see table) or the self acquired multiplied 10 times (multiplication factor x 10).

▫ Fault

output U3 On = failed the test operation, triggered by a negative pulse (min 0.5 sec.) on pin 3 (Test Input): If pin 3 is connected to a short time to pin 2 (Negative Power Supply) is automatically activated the test procedure that verifies the proper operation of the entire probe.

The lack of activation of the output U3 and its Led L4 indicate proper operation of the probe and passing the test

Outputs

▫ U1 (pin 7) Normally open output with J2 opened; normally closed with J2 closed.

▫ U2 (pin 8) Normally open output with J2 opened; normally closed with J2 closed.

▫ U3 (pin 9) Normally open output with J2 opened; normally closed with J2 closed.

Self-Acquisition

The probe allows two setup modes:

The manual setup provides for the operation of the thresholds in function of a default value set by the manufacturer or on demand.

The automatic setup provides the acquisition of the value, the normal concentration of dust in normal operating conditions and in fully automatic mode by pressing the button P1.

The switch J1 defines the type of setup.

The output OUT1 will go ON exceeded 5 times the normal concentration (CN) and will provide a pre-alarm.

N.B. Activating the self-acquisition, the values (in mg/m³) of the thresholds 1 and 2 will not match with the table relative to the available versions.

Test Procedure

To test the proper operation of the probe, connect pin 3 (test input) to pin 2 (negative power), for a longer time than 0.5 sec.

The led relating to fault threshold (led 4) and the system will start a procedure for the verification of the proper functioning of the entire probe.

Will be verified with all the circuits and all the amplification stages of input, including the presence of leakage current on the electrode.

Two cases can occur:

1) after about 30 sec. from the start of the test, the fault output U3 will be activated for about 60 seconds. This is the condition of failure the test.

2) after about 90 seconds. from the start of test, the fault output U3 is not activated. This is the condition of passing the test.

In any case, after about 90 seconds from the start of test, the probe will resume the normal operation mode regardless of the result of the test.

In case of failure of the test, it is recommended to remove the probe and provide a careful cleaning of the electrode and the insulator, so you should also check for the presence of water infiltration.

Next, replace the probe and repeat the test.

Electrical Connections

Ground Connection

Use the cable that is supplied with the probe, secure under one of the two screws securing the cover, positioning the washer under the lug.

The other lug must be screwed to the pipe that must be grounded.

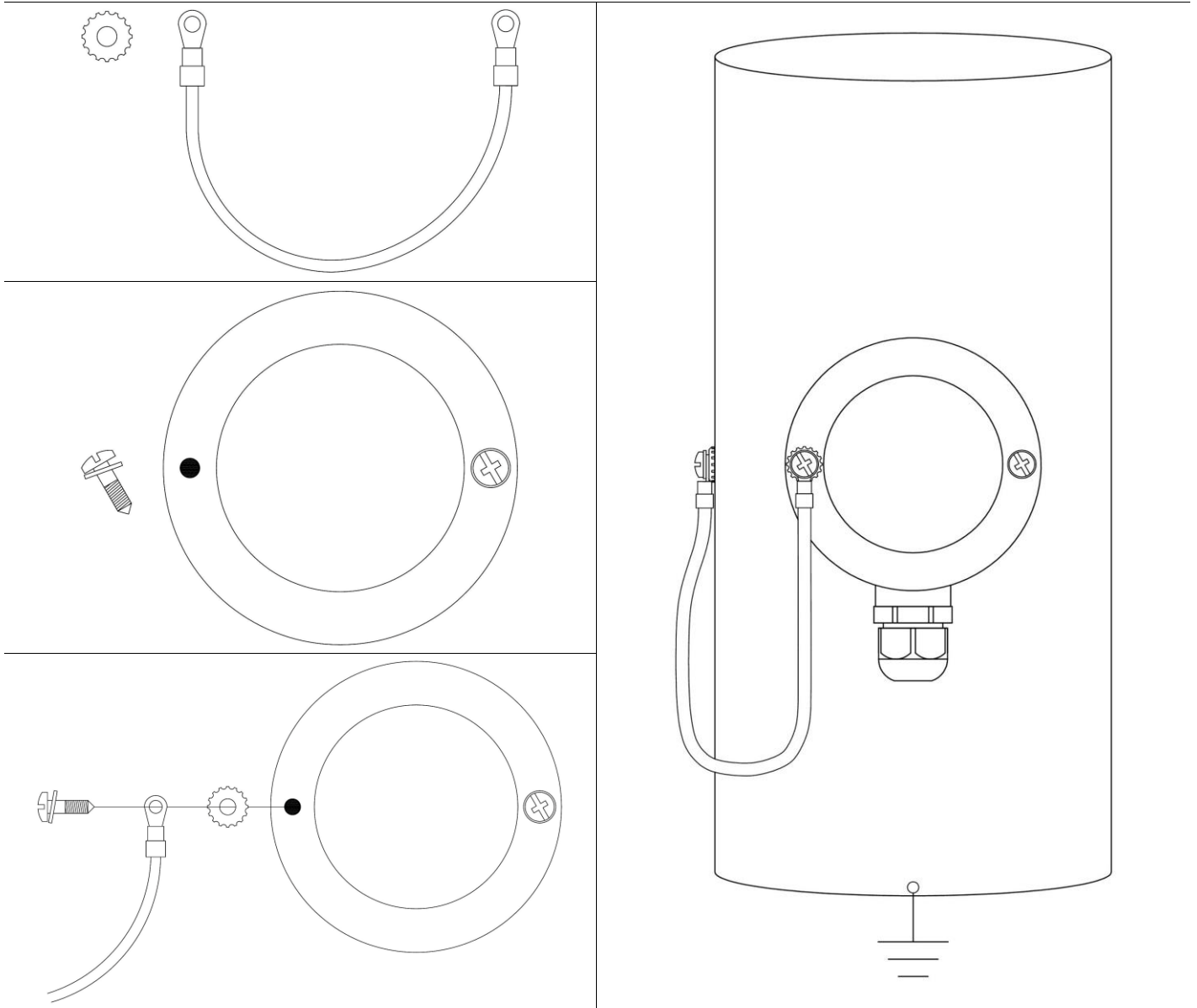

Connecting Power And Signals

The probe must be supplied with a voltage between 20 and 30V DC.

The opto isolated open collector outputs (protected by a self-resetting fuse) accept a maximum voltage 48 VAC and a maximum current of 100 mA. PWM current output 4/20 but is fully opto-isolated. The probe is galvanically isolated from the power supply.

Electrical Connection Sample

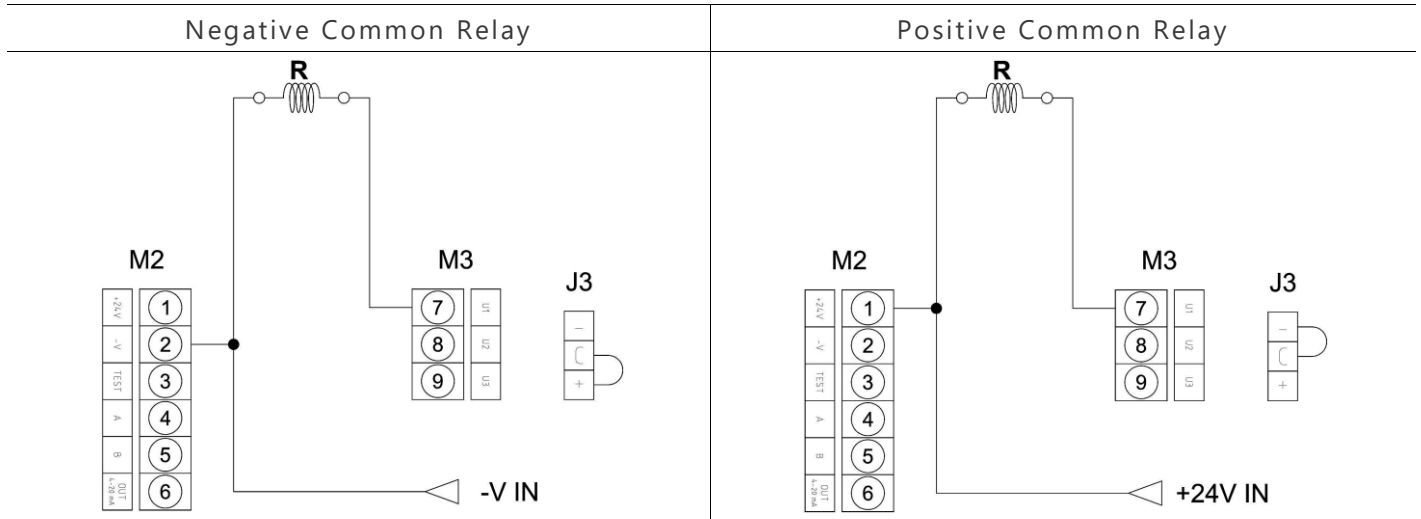

Electrical Connection Sample Of 4/20 mA Output

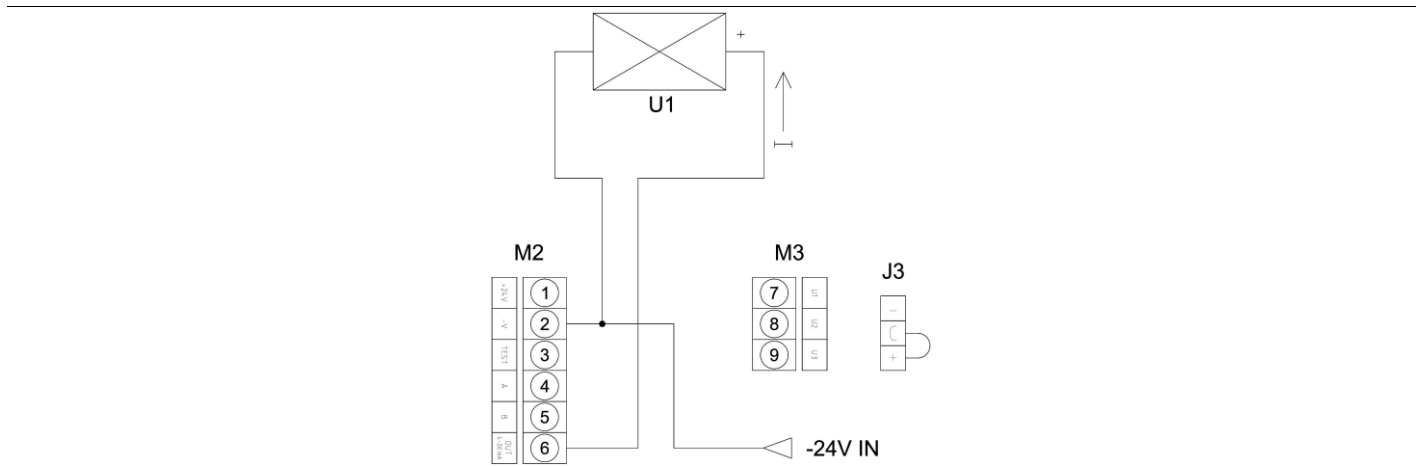

U1 Utilizer Eg PLC

Technical Features

Power supply	20 / 30 Vdc
Maximum power consumption	1 W
Resolution	0,1 mg/m ³ , 0,01 mg/m ³ see versions
Range settings	Automatic / Manual
Size dust particles	> of 0.3 µm
Type of measurable products	Dust particles in gaseous fluid
Flow velocity	> of 4 m/s
Measuring principle	Charge Displacement
Alarm 1 threshold	See table of available versions
Alarm 2 threshold	See table of available versions
Alarm 3 threshold (fault)	Automatically activated by the function of test
Alarm outputs	n. 3 outputs with solid state relay, fuse-protected auto resetting
Maximum current outputs	100 mA
Maximum applicable voltage outputs	48 V
Output functions	Adjustable normally closed or normally open. Common to negative or positive (see wiring examples)
Probe working temperature	< of 140 ° C
Working pressure of the probe	< 2 bar's
Electrode material	Stainless steel aisi 304
Box material	Aluminum
Moisture	< 95% Non Condensing
Room temperature for electronics	-20 / +60 ° C
Dimensions	DIN A
Measurable elements	All Non-Aggressive Gases
Electrical connection	3-Pin Terminal Block 1 + 1 6-Pin Terminal Block
Mechanical connection to the structure	3/4" G
Degree of protection	IP 65
Display	n. 4 led
PWM output 4/20 mA	Active Output, Optoisolated. Max Load 500 Ohm
Serial output	RS485 2-Wire
Certifications	CE/AtEx Zone 22 D upon request

Maintenance

Periodically, depending on the type of plant and therefore the type of expulsions, both as a quantity that as size (wet material, sticky, etc.). Verify the status of the stylus / electrode of the probe, if there are accumulations of dirt and / or condensation between the electrode and the metal mount (nipple) to the container, which could offset measurements.

Perform at least one inspection every 4-6 months.

Emissions of oily fumes make the dust stick to the sensitive rod, this it alters changes the reading of the probe and forces more frequent cleaning operations.

Warnings

The use of the probe is allowed only in modes described in this manual

Follow the instructions in this manual literally before installation or servicing

The installation and maintenance of the probe should be performed only by qualified personnel.

NOTES:
