



## Specialty Gas Equipment Catalogue



### Gas Delivery Systems

When gases are used in significant volumes, a centralized gas delivery system is a practical necessity. A well-conceived delivery system will reduce operating costs, increase productivity and enhance safety.

A centralized system will allow the consolidation of all cylinders into one storage location. With all the cylinders in one place, inventory control will be streamlined and cylinder handling will be simplified and improved. Gases can be separated by type to enhance safety.

With gas delivery systems the frequency of cylinder changeouts are reduced. This reduction is achieved by connecting multiple cylinders to supply panels in banks in such a way that one bank can be safely vented, replenished and purged while a second bank provides continuous gas service. This type of system can supply gas to multiple applications and even entire facilities, eliminating the need for separate cylinders and regulators for each point of use.

Since cylinder switchover can be accomplished automatically by the supply panel, cylinders in a bank will be uniformly exhausted, resulting in improved gas utilization and lower costs. The integrity of the delivery system will be better protected since cylinder changeouts will be done in an isolated, controlled environment.



### Purity

The level of gas purity required at each point of use is extremely important in designing a gas delivery system. Maintaining the gas purity is simplified with a centralized system as described above. Selection of materials for construction should be consistent throughout. For example, if a research grade gas is being utilized, all stainless steel construction and diaphragm packless shut-off valves should be used to eliminate contamination of the gas stream.

In general, three levels of purity are sufficient to describe nearly any application. The first level, usually described as a multi-purpose applications, has the least stringent purity requirement. Typical applications may include welding, cutting, laser assist, atomic absorption or ICP mass spectrometry. Gas supply panels for multipurpose applications are economically designed for safety and convenience. Acceptable materials for construction include brass, copper, Teflon®, Tefzel® and Viton®. Packed valves, such as needle valves and ball valves, are often used for flow shut-off. Gas distribution systems manufactured to this level should not be used with high purity or ultra-high purity gases.

The second level, called high-purity applications, requires a higher level of protection against contamination. Applications include laser resonator gases or chromatography where capillary columns are used and system integrity is important. Materials of construction are similar to multi-purpose manifolds, except flow shut-off valves are diaphragm packless to prevent diffusion of contaminants into the gas stream.

The third level is referred to as ultra-high purity applications. This level requires the highest level of purity for components in a gas delivery system. Trace measurement in gas chromatography is an example of an ultra-high purity application. Wetted materials for manifolds at this level must be selected to minimize trace components adsorption. These materials include 316L stainless steel, Teflon®, Tefzel® and Viton®\*. All tubing should be 316SS cleaned and passivated. Flow shut-off valves must be diaphragm packless. It is particularly important to recognize that components that are suitable for multi-purpose applications may adversely affect results in high or ultra-high purity applications. For example, out-gassing from neoprene diaphragms in regulators can cause excessive baseline drift and unresolved peaks.

\*Teflon®, Viton® and Tefzel® are registered trademarks of The Chemours Company



## Types of Gas Delivery Systems

### SINGLE STATION SYSTEMS

In some applications, a gas is used only to calibrate instrumentation. For example, a continuous emissions monitoring system (CEMS) may only require calibration gases to flow for a few minutes each day. Such an application clearly does not require a large-scale automatic changeover manifold. However, the delivery system should be designed to protect against contamination of the calibration gas and to minimize costs associated with cylinder change-outs.

A single station supply panel with bracket is an ideal solution for this type of application. It provides a safe and cost-effective means of connecting and changing out cylinders by eliminating the need to struggle with the regulator. When the gas includes corrosive components such as HCl or NO, a purge assembly should be incorporated into the manifold to allow the regulator to be purged with an inert gas (usually nitrogen) to protect it from corrosion. The single station panel can also be equipped with a second pigtail. This arrangement allows an additional cylinder to be connected and held in reserve. Switchover is accomplished manually using the cylinder shut-off valves. This configuration is usually desirable with calibration gases since the precise mix of components generally varies somewhat from cylinder to cylinder. A cylinder change may require resetting the instrument.



### SEMI-AUTOMATIC SWITCHOVER SYSTEMS

Many applications require continuous use and/or larger volumes of gases beyond what is practical for a single station manifold. Any pause in the gas supply results in lost or ruined experiments, a loss of productivity and even downtime for an entire facility. Semi-automatic switchover systems provide the capability to switch from a primary to a reserve cylinder or bank without interrupting the gas supply, thus minimizing costly downtime. Once the primary cylinder or bank is depleted, the system automatically switches to the reserve cylinder or bank for continuous gas flow. The user then changes the empty cylinders for new cylinders, while the gas is still flowing from the reserve side. A bi-directional valve is used to indicate the primary or reserve side during cylinder change-out.

### FULLY AUTOMATIC PROGRAMMABLE SWITCHOVER SYSTEMS

In some critical manufacturing and laboratory processes, an uninterrupted gas supply is an absolute necessity. Failure of the gas supply in these facilities can result in loss of an entire laboratory's in-process experiments or even shutdown of manufacturing production line or process. The potential cost of either of these events is so high that the installation of a gas delivery system, designed to provide an uninterrupted gas supply, is clearly justified. A fully automatic programmable switchover system is generally selected for these applications.



## HPI 100P High purity one-sided supply panel

The HPI 100P is a high purity gas supply panel. Manual adjustment of the regulator allow the user to set downstream pressure. The system includes purge function. Designed for applications where a slight rise in delivery pressure from full to empty cylinder can be tolerated or as first stage of pressure reduction.

### APPLICATIONS:

- Laboratory pressure control
- Research sample systems gases
- Component testing
- Petrochemical industry
- Emission monitoring systems
- Controlled atmosphere
- Service & test equipment

### FEATURES:

- Recommended gases purity levels up to grade 6.0 (99.9999)
- Stainless steel version applicable also for corrosive gases after prior confirmation of the material's compatibility
- Wall mounting panel and brackets included
- Ready to install wall mounting panel
- 316L stainless steel diaphragm eliminates contamination from diffusion or outgassing
- Purge function and diaphragm shut-off valves for the best results
- Possible to connect 2 gas cylinders or gas cylinder and a gas for purging operation
- HPI 100PC - chrome-plated body, bonnet and fittings
- HPI 100PS - 316L stainless steel body, bonnet and fittings
- $1 \times 10^{-9}$  mbar l/s He inboard helium leak rate to maintain gas purity levels
- Inlet / outlet - 1/4" FNPT
- Maximum inlet pressure 300 bar (4350 psig)
- External relief valve standard
- Cleaned for oxygen service

### TECHNICAL DATA:

Panel type	One-sided
Regulator type	Single-stage
Purity	Up to 6.0
Inlet pressure	Max. 300 bar (4350 psi)
Outlet pressure	2/4/10/20 bar (29/58/145/290 psi) 50/100/200 bar (720/1450/2900 psig)
Purge function	Yes
Oxygen use	Suitable

### MATERIALS:

Body, bonnet	316L stainless steel barstock or chrome-plated brass barstock
Diaphragm (regulator)	Hastelloy®*C276
Diaphragm (valve)	Elgiloy®**
Nozzle	316L stainless steel
Seat	PEEK
Seals O-ring	Viton®*** (FKM)
Filter	SS 316L
Adjusting Knob	ABS plastic

\* Hastelloy® is a registered trademark name of Haynes International, Inc

\*\*Elgiloy® a registered trademark of Elgiloy Specialty Metals

\*\*\* Viton® is a registered trademark of The Chemours Company



Model shown with additional accessories to be ordered separately

### RELATED OPTIONS:

4302085	ALARM, 1 connection
4302086	ALARM, 2 connections
4302087	ALARM, 4 connections
4302088	ALARM, 6 connections
4302089	ALARM, 10 connections



## SPECIFICATIONS:

Inlet / outlet ports	1/4" FNPT
Weight	3,3 kg

## FLOW CHART:

### HPI 100P

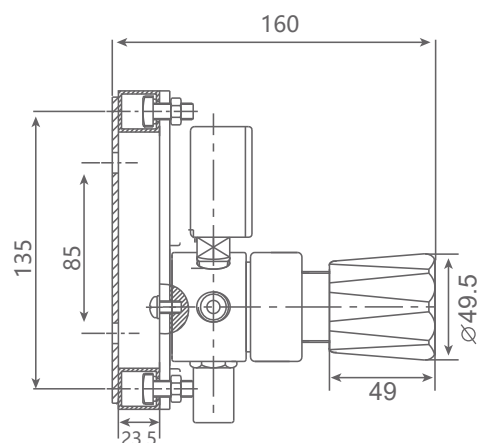
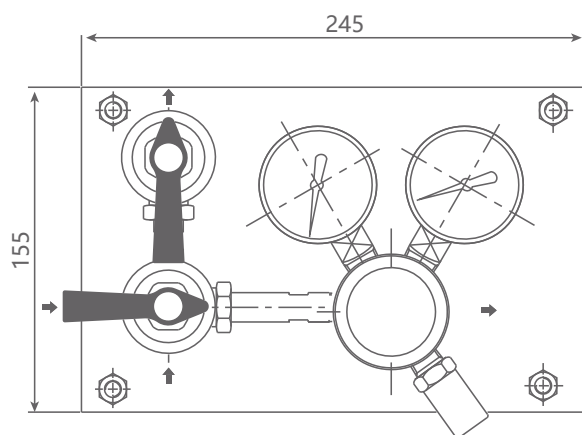
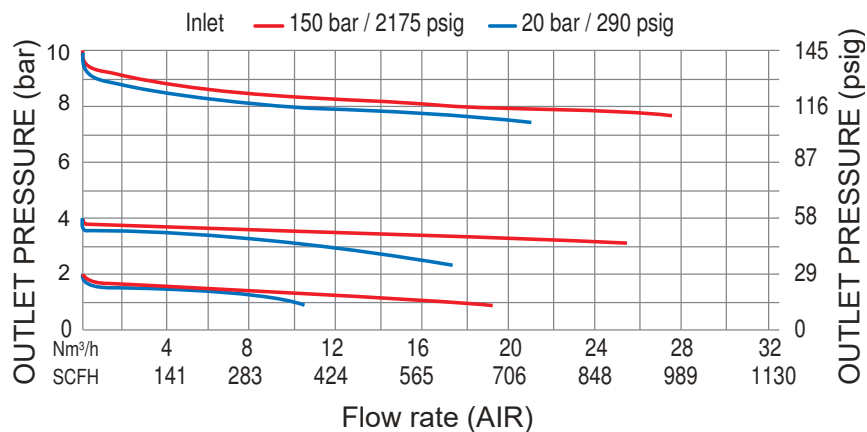

## ORDERING INFORMATION:

MODEL	MATERIAL	OUTLET PRESSURE	GAS TYPE
HPI 100PC	Chrome-plated brass	0 - 2 bar 0 - 29 psig	Please specify
HPI 100PS	Stainless steel	0 - 4 bar 0 - 58 psig	
		0 - 10 bar 0 - 145 psig	
		0 - 20 bar 0 - 290 psig	

For example:

HPI 100PC 290 N<sub>2</sub>