

Diaphragm pressure gauge in chemical version NG 100

Application	For gaseous and liquid, also aggressive, low-viscosity media, high overpressure safety, with open lower flange also for high-viscosity media. With fluid filling for measuring points subject to vibrations and high dynamic pressure loads
Ambient temperature	-20°C to +60°C
Media temperature	Max 100°C
Temperature dependent display error	< 0,8% / 10K
Pressure range	Flange ø 100 mm, 0.4 to 25 bar Flange ø 150 mm, 60 to 250 mbar
Overpressure safety (with ordering code 0201)	Flange ø 100 mm, 400 mbar, 2.5 x Flange ø 100 mm, from 0.6 bar, 5 x, max. 40 bar Flange ø 150 mm, 10 x
Range of application	For static pressure 100% of full scale For dynamic pressure 90% of full scale
Accuracy	Cl. 1,6 according to DIN EN 837-3
Execution	DIN EN 837-3
Movement	Stainless steel
Dial	White, black scale acc. EN 837-3
Pointer	Aluminium, black, DIN EN 837-3
Window	Multilaminated safety glass
Case	Welded, with blow-out lid, back (S1 acc. DIN EN 837-3)
Protection	IP 65 acc. EN 60529 / IEC 529 higher protection class possible as an option (see overleaf)



Selection Chart

Ordering code	DPx 100 / xxx.xxx		
System design			
Standard	DPC		
With liquid, glycerine 86%	DPO		
Nominal size			
NG 100	100		
Case			
Stainless steel 1.4301, bright drawn, welded	8		
Structural shape			
Direct mounting	1		
Upper flange			
Ø 100 stainless steel 1.4301	3		
Ø 150 stainless steel 1.4301	6		
Scale			
Standard	1		
Measuring element			
Duratherm 600* with Viton seal	(E)	3	
Duratherm 600* with PTFE coating 1)	(P)	5	
Lower flange			
Male connection G½, stainless steel 1.4571		3	
For further lower flanges see below		9	

Special versions

For special versions see page 3

Notes:

*CoNiCr alloy, durability similar to 1.4571

1) for flange ø 150 with PFA coating

2) only possible without filling

Display range corresponding to upper flange \varnothing

Order number	\varnothing 150 mbar	Measuring element	Order number	\varnothing 150 mbar	Measuring element	Order number	\varnothing 100 bar	Measuring element	Order number	\varnothing 100 mbar	Measuring element
116 ²⁾	0 ... 60	E	736	- 100 ... 60	EP	015	0 ... 0.6	EP	156	0 ... 400	E
126	0 ... 100	EP	746	- 100 ... 150	EP	025	0 ... 1.0	EP	436	- 400 ... 0	E
136	0 ... 160	EP	756	- 150 ... 100	EP	035	0 ... 1.6	EP	766	- 150 ... 250	E
146	0 ... 250	EP	766	- 150 ... 250	P	045	0 ... 2.5	EP	776	- 250 ... 150	E
156	0 ... 400	P	776	- 250 ... 150	P	055	0 ... 4	EP	786	- 200 ... 400	EP
396 ²⁾	- 60 ... 0	E				065	0 ... 6	EP	796	- 400 ... 200	EP
406	- 100 ... 0	EP				075	0 ... 10	EP	806	- 400 ... 600	EP
416	- 160 ... 0	EP				085	0 ... 16	EP	816	- 600 ... 400	EP
426	- 250 ... 0	EP				095	0 ... 25	EP			
436	- 400 ... 0	P				305	-0.6 ... 0.0	EP			
686 ²⁾	- 20 ... 40	E				315	-1.0 ... 0.0	EP			
696 ²⁾	- 40 ... 20	E				505	-1.0 ... 0.6	EP			
706	- 40 ... 60	EP				515	-1.0 ... 1.5	EP			
716	- 60 ... 40	EP				525	-1.0 ... 3	EP			
726	- 60 ... 100	EP				535	-1.0 ... 5	EP			
						545	-1.0 ... 9	EP			
						555	-1.0 ... 15	EP			

Dimensions

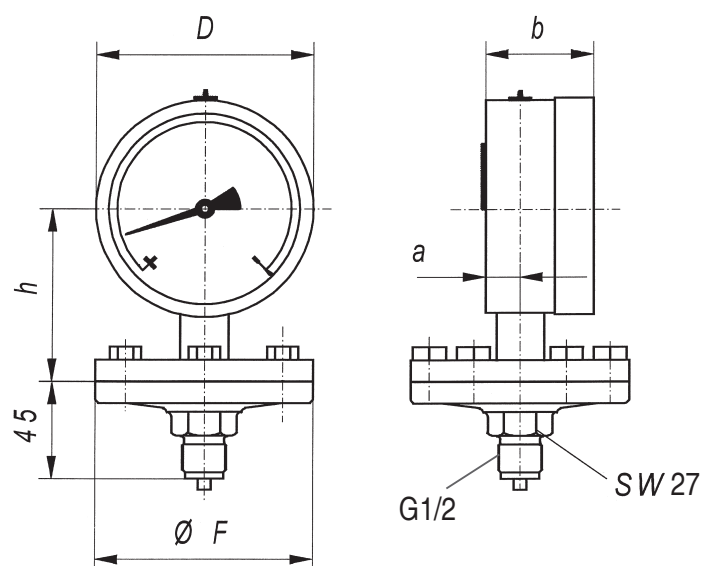

Size table

NG	D	a	b	h	F	Weight in kg	
						DPC	DPO
100	101	16	50	81	100	approx. 1.7	approx. 2.0
					150	approx. 3.0	approx. 3.4

Notes: ²⁾Dependent on lower flange (value of male lower flange)

Lower flanges

Lower flange	ø 100 mm		ø 150 mm	
	Ordering code	Ordering code with PTFE	Ordering code	Ordering code with PTFE
Plugs				
G ^{1/2}	Standard	0302	Standard	0304
1/2"-NPT	0024		0024	
M 20x1,5	0013		0013	
DIN 2501				
PN 10 to	DN 15	0342	0356	
40 bar	DN 25	0344	0358	0362
	DN 50	0372	0378	0364
ANSI				
PN 300 to	DN 1/2"	0422	0442	
600 lbs	DN 1"	0426	0446	
	DN 2"	0430	0450	0470

Notes: for flange dimensions see chapter A23, data sheet D1.395

Special versions

Components	Special design	Ordering code	Remark
Ring	Gloss brushed	0106	
Protection	Air and watertight to IP 67	0114	
Measuring system	overpressure safe	0201	
Pointer	Micro-adjustable pointer	0678	
	Dial inscription: «P _{abs} » (pointer at 1 bar)	0691	
Dial	Unscaled, start and end values marked	0725	
	Red mark at...	9700	
	Green mark at...	9701	
	Display same as/similar to catalogue, but different unit of measurement	9704	
	Display same as/similar to catalogue, but different scaling	9705	
	Customer logo	9710	
	Techn. inscription	9711	
Case filling for DPO	Dampening liquid glycerine 86%	(-25°C ...100°C) 0774	Standard
	Dampening liquid glycerine 99,5%	(5°C ...100°C) 0775	
	Dampening liquid silicone oil AK 100	(-35°C ...100°C) 0776	
	Dampening liquid paraffin oil	(-10°C ...100°C) 0777	
Miscellaneous	Screws secured with "Loctite"	0799	

UK/2009-10-05 This data sheet may only be reproduced in full.