

Diaphragm Valve



Sanitary valves feature high cleanliness and low residue, and are widely used in fields such as pharmaceutical, beverage, food and fine chemical fluid control, with the characteristics of high safety and high reliability. The diaphragms used in the products comply with the safety standards stipulated by authoritative organizations like the FDA and USP for the pharmaceutical and food industries, so as to meet various requirements and conditions of customers and use high-quality products to adapt to the demands of the gradually developing new technology market.

Application Industry

Pharmaceutical, food and beverages, cosmetics, brewing, chemicals, etc.



The ESG series of sanitary diaphragm valves adopts a modular design. You can choose different valve bodies, diaphragms and actuators according to your needs.

Control Accessory

Mechanical
OverrideProximity
Switch

Position Indicator

Intelligent Positioner

Two-piece Intelligent Positioner

Actuator



Pneumatic Actuator

Manual Actuator

Diaphragm



Double Layer

Single Layer

Valve Body

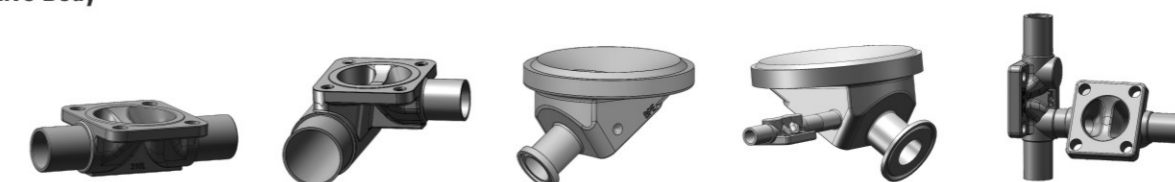

Two-Way Valve

T-Shape Valve

Tank Bottom Valve

Tank Bottom
Combination Valve

Combination Valve

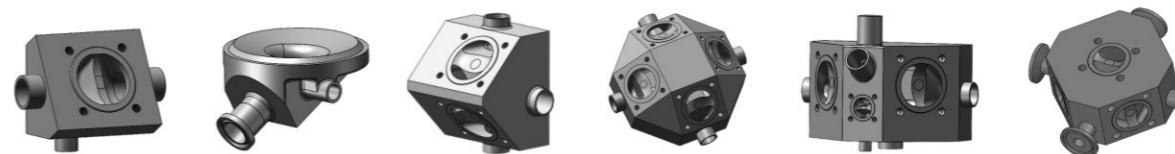

i-body Valve

Tank Bottom
Combination Valve

Multi-port Valve Block

Water Machine
System Valve BlockChromatography
System Valve Block

Diaphragm Valve

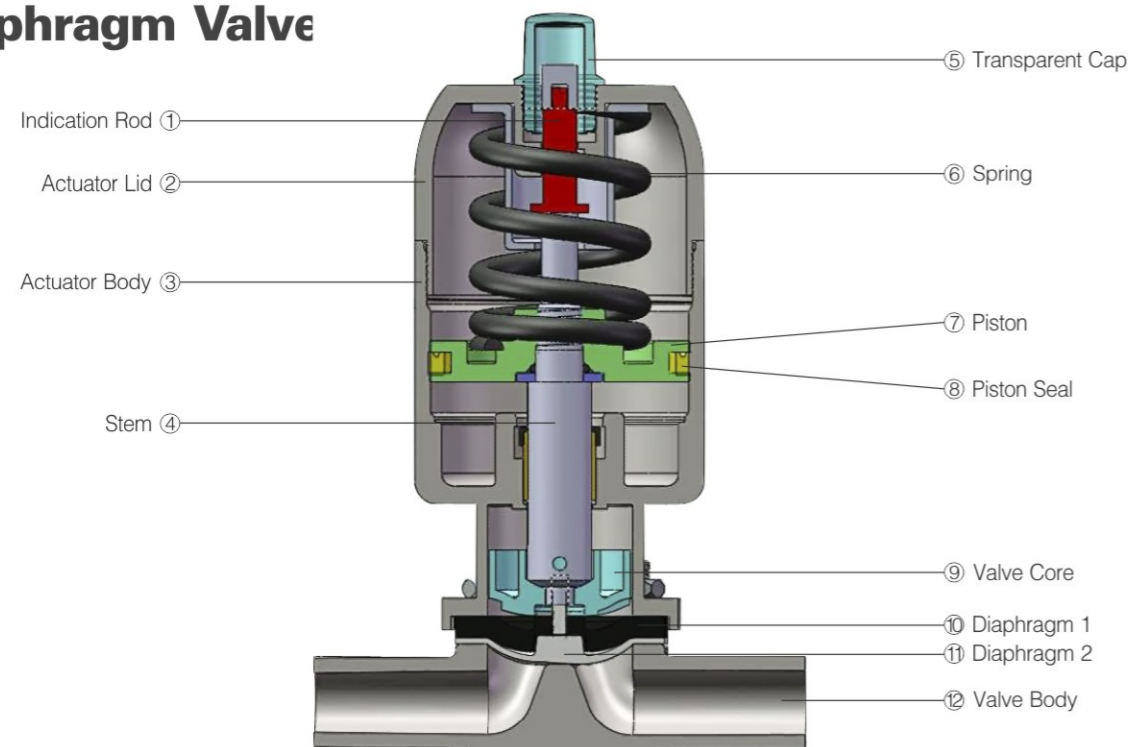

Technical Specification

- Material: (Body) Investment casting CF3M, Forged F316L (Customized special materials)
(Pneumatic) Actuator + Valve seat CF8; (Manual) Valve seat CF8
- Internal surface: $Ra \leq 0.4 \mu m$, mechanically polished (Electro-polishing optional)
- Diaphragm material: EPDM + PTFE (double-layer diaphragm),
EPDM (Single-layer diaphragm)
- Operating pressure: 0–10bar (0–145psi)
- Fluid temperature: $-10^{\circ}C - 130^{\circ}C$ (sterilization at $150^{\circ}C$ for 60mins)
- Control pressure(pneumatic): 4.5–7bar (65–102psi)

Installation Angle($\pm 1^{\circ}$)

Size	ASME BPE	SMS3008	JIS-G 3447	1127/ DIN 11866-B	11850-0	11850-1/2/3 DIN 11866-A
	A	A	A	A	A	A
DN8	37	/	/	/	/	/
DN10	32	/	/	/	/	/
DN15	28	/	/	24	28	27
DN20	27	/	/	29	34	33
DN25	30	29	29	19	26	23
DN40	27	34	26	18	23	23
DN50	22	22	22	17	20	20
DN65	12	/	/	/	/	/

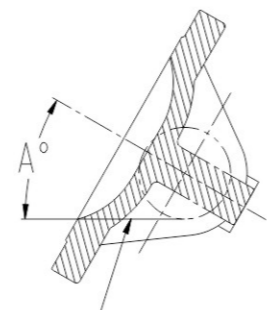
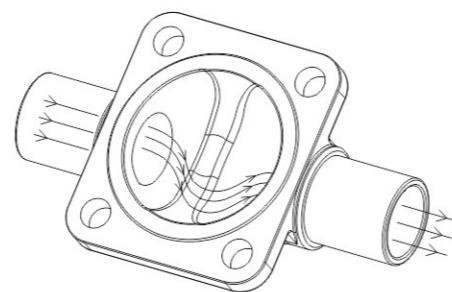

The optimal angle is when the tangent line between one end of the Weir and the inner hole of the pipeline is horizontal.

Typical Applications

Fermentation tank, Preparation vessel, Filling machine, Sterilizing equipment, Aseptic fluid transfer, CIP/SIP, etc.

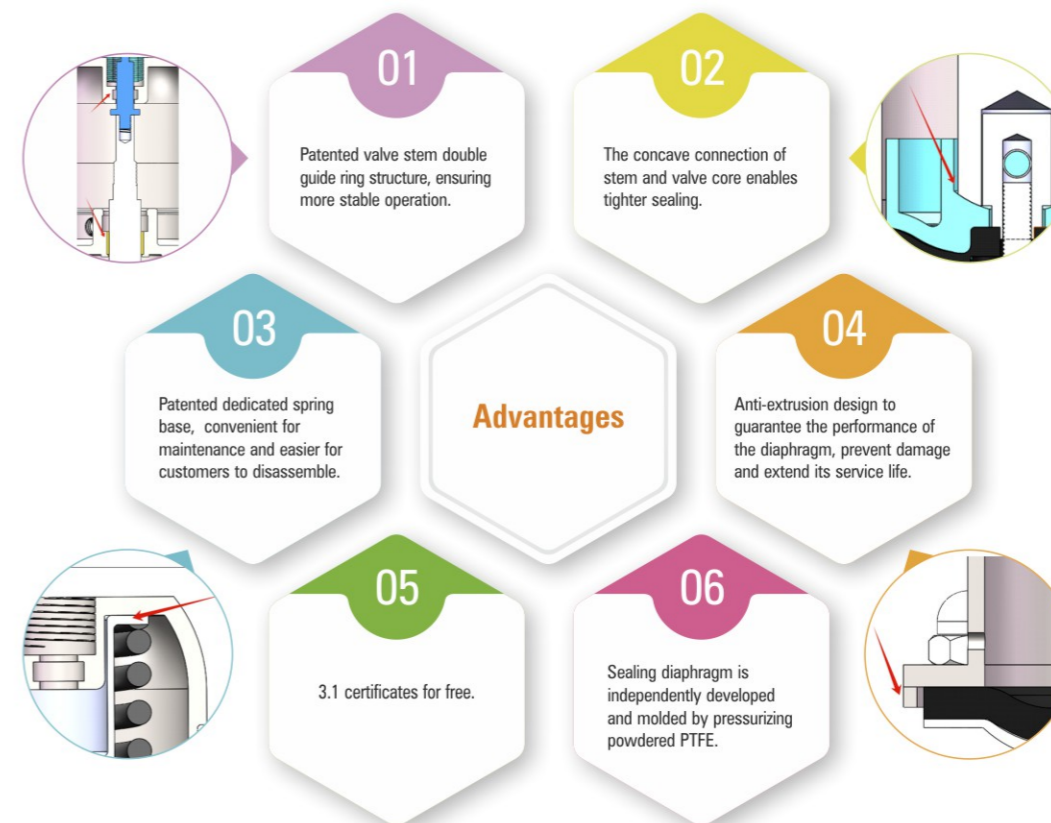

Advantages

Double-Layer

The PTFE + EPDM double-layer diaphragm is a high-standard diaphragm form used in sanitary diaphragm valves internationally. The PTFE diaphragm is a product independently developed by ESG. It adopts imported raw materials and is processed and molded by using high-temperature compression molding technology. It is widely used in fields such as blood products, vaccines, biopharmaceuticals, injections, aseptic production, fermentation, water for injection supply and distribution loops.

The EPDM diaphragm on the double-layer not only plays a role in protecting the PTFE diaphragm that contacts the product but also can enhance the sealing effect of the PTFE diaphragm.

Single-Layer

The EPDM single diaphragm is suitable for hot water, cold water, alkaline and weakly acidic media as well as vacuum working conditions. It is especially applicable to polar substances and steam media and is highly suitable for sanitary applications.

It is not recommended to use the EPDM diaphragm for media such as mineral oils and vegetable oils, plant and animal fats, aliphatic or aromatic hydrocarbons, halogenated solvents or concentrated acids, which may cause damage to the diaphragm and lead to leakage.

Diaphragm Introduction

* Diaphragms can be ordered separately.



	Working temperature
Single layer <EPDM>	$-10^{\circ}C - 130^{\circ}C$ (灭菌 $150^{\circ}C$, 60mins)
Double layer <EPDM+PTFE>	

Diaphragm Valve

Quality Control

1. Valve assembly inspection:
100% inspection according to the shipping inspection form.
2. Diaphragm valve seal test:
100% valve assembly seal test, tested according to DIN EN 12266-1.
3. Inner surface finish:
100% IPQC (in-process control), roughness sampling test according to GB2828.
4. Contact surface inspection:
Material testing—Spectrometer; Three-Dimension inspection—Coordinate Measuring Machine.
5. Qualification:
Quality Management System ISO9001, Food Contact Raw Materials and Products Directive EC1935-2004, Explosion-proof Safety ATEX Directive 2014/34/EU.



Roughness - Profile Integrated Inspection Instrument



Spectro - Spectrometer

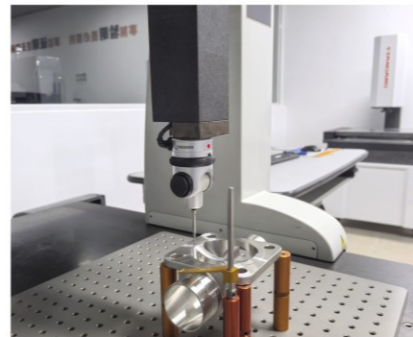

Hexagon - Coordinate Measuring Machine

Certification

Certification of Diaphragm Valves (Whole Valve) and Diaphragms

<p>Test Report No. TCH0191020701 QINGDAO ELITE MACHINERY MANUFACTURE CO., LTD TONGJI INDUSTRY ZONE, JIANGSU PROVINCE, CHINA</p>	<p>Test Report No. SH4H310304401 QINGDAO ELITE MACHINERY MANUFACTURE CO., LTD Tongji Industry Zone, Jiangsu, China</p>	<p>Attachment 1: Test for in vitro cytotoxicity (ELIM) SUMMARY All in vitro cytotoxicity study was conducted to assess the potential PTFE Diaphragms, based on the USP40-877, BIODIGITAL, RE... Under the conditions of this study, the test article met the requirement and the positive controls performed as anticipated.</p>	<p>Certificate of Receipt of Technical Document Number: CML 18ATEXT1053 Issue 0 1. In accordance with Directive 2014/34/EU, Article 13, 1, certificate confirms receipt of a dossier of technical documents... 2. This certificate is evidence that the manufacturer has communicated the dossier of technical documents in accordance with the requirements of Directive 2014/34/EU... 3. Certification Management Limited, is a notified body in control of Directive 2014/34/EU Articles 17 and 26. 4. Manufacturer name # Qingdao Elite Machinery M... 5. Address # No. 18, Jiangsu Road, T1 Qingdao, China 6. Manufacturer file reference # Equipment # TCF-VC-AN-2018012801 Angle Seal Valve, Check Valve, Steam Valve, Steam Trap, Nozzle DN8-100 The apparatus mark CE 2010 c T4</p>	<p>Report No. R-USP88-KL20190117 Client: QINGDAO ELITE MACHINERY MANUFACTURE CO., LTD. Testing Institution: Biocompatibility Lab. of LEON Biotech. Co., Ltd. Report No. R-USP88-KL20190117</p>
---	--	--	--	--

● EC 1935 / FDA(Food and Drug Administration) Certificate / USP(US Pharmacopeia) Certificate / ATEX anti-explosion certificate

A00 Series Welded Pneumatic Diaphragm Valve



A00 Series Tri-Clamp Pneumatic Diaphragm Valve



Order Instruction

A00	XXX	X	XXX	XX	X	X	X	X	(*)
Series No.	Diaphragm M08, M10, size M25, M40, M50	Control type 1: Single acting normally closed	Size D08, D10, D15, D20, D25, D40, D50, D65	Polishing 1: Mechanical polishing ≤0.4 μm 2: Electropolishing	Diaphragm material A: PTFE+EPDM (Double-layer diaphragm) B: EPDM (Single-layer diaphragm)	Actuator material 1: CF8	Body material 6: CF3M G: F316L	Connection type H1: Welded ASME-BPE H2: Welded SMS3008 H3: Welded JIS-G3447 H4: Welded ISO1127/DIN11866 B H5: Welded DIN11850-0 H6: Welded DIN11850-1 H7: Welded DIN11850-2/DIN11866 A H8: Welded DIN11850-3	*: Special customization K1: Tri-clamp ASME-BPE K2: Tri-clamp SMS3008 K3: Tri-clamp JIS-G3447 K4: Tri-clamp ISO1127 K5: Tri-clamp DIN11850 K6: Tri-clamp ASME-BPE EN558-1

Diaphragm Valve

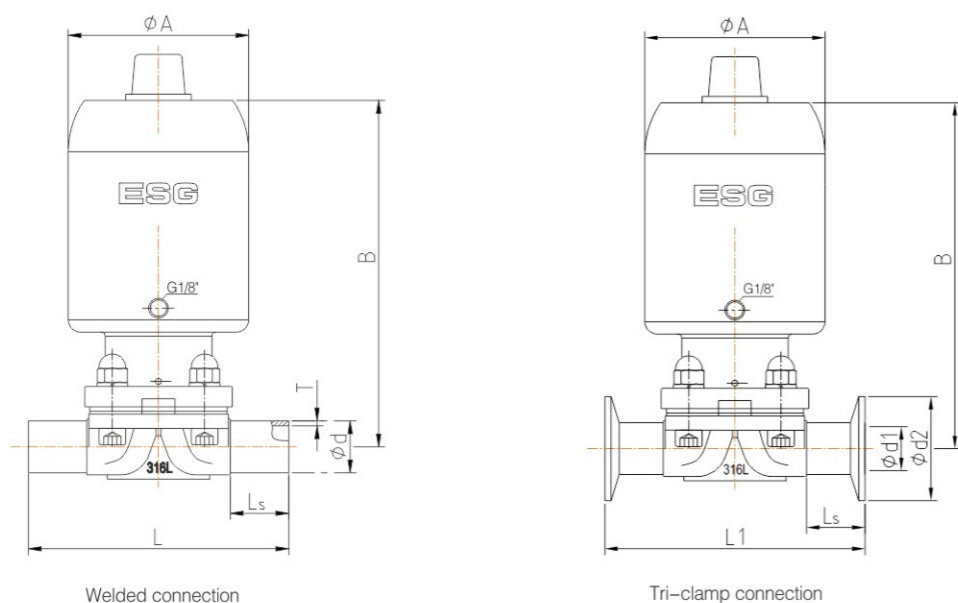

* If the valve is in a normally open state, the G1/8" air inlet port is located on the side of the cylinder barrel at the upper position.

Main Dimension

Pneumatic diaphragm valve -Welded connection						ASME-BPE	SMS3008	JIS-G3447	ISO-1127	DIN-11850				DIN-11866		
Size	Diaphragm	Actuator	φA	B	Ls	L	φd × T	φd × T	φd × T	φd × T	-0	-1	-2	-3	A	B
DN8	8	42	47	85	20	72	6.35 × 0.89	-	-	-	-	-	-	-	-	-
DN10	8	42	47	85	20	72	9.53 × 0.89	-	-	-	-	-	-	-	-	-
DN15	8	50	57	106	17	72	12.70 × 1.65	-	-	-	-	-	-	-	-	-
	10	57	65	134	29.5	108	-	-	-	21.3 × 1.6	18 × 1.5	18 × 1.0	19 × 1.5	20 × 2	19 × 1.5	21.3 × 1.6
DN20	10	57	65	134	29.5	108	19.05 × 1.65	-	-	-	-	-	-	-	-	-
	25	80	88	170	26.5	120	-	-	-	26.9 × 1.6	22 × 1.5	22 × 1.0	23 × 1.5	24 × 2	23 × 1.5	26.9 × 1.6
DN25	25	80	88	170	26.5	120	25.4 × 1.65	25.0 × 1.2	25.4 × 1.2	33.7 × 2	28 × 1.5	28 × 1.0	29 × 1.5	30 × 2	29 × 1.5	33.7 × 2
DN40	40	105	109	196	30	153	38.1 × 1.65	38.0 × 1.2	38.1 × 1.2	48.3 × 2	40 × 1.5	40 × 1.0	41 × 1.5	42 × 2	41 × 1.5	48.3 × 2
DN50	50	125	129	226	30.5	173	50.8 × 1.65	51.0 × 1.2	50.8 × 1.5	60.3 × 2	52 × 1.5	52 × 1.0	53 × 1.5	54 × 2	53 × 1.5	60.3 × 2
DN65	50	125	129	232	30.5	173	63.5 × 1.65	-	-	-	-	-	-	-	-	-

Pneumatic diaphragm valve -Tri-clamp connection						ASME-BPE		ASME-BPE EN558-1 Series 7				SMS3008		JIS-G3447		ISO-1127		DIN-11850										
Size	Diaphragm	Actuator	φA	B	φd1	φd2	Ls	L1	φd1	φd2	Ls	L1	φd1	φd2	Ls	L1	φd1	φd2	Ls	L1	φd1	φd2	Ls	L1				
DN8	8	42	47	85	4.57	25	15.5	63.5	-	-	-	-	-	-	-	-	-	-	-	-	-	-	-	-	-			
DN10	8	42	47	85	7.75	25	15.5	63.5	-	-	-	-	-	-	-	-	-	-	-	-	-	-	-	-	-			
DN15	8	50	57	106	9.4	25	15.5	63.5	9.4	25	35	108	-	-	-	-	-	-	-	-	-	-	-	-	-			
	10	57	65	134	-	-	-	-	-	-	-	-	-	-	-	-	18.1	50.5	29.5	108	16.0	34	29.5	108				
DN20	10	57	65	134	15.75	25	26.3	101.6	15.75	25	34	117	15.75	25	34	117	-	-	-	-	-	-	-	-	-			
	25	80	88	170	-	-	-	-	-	-	-	-	-	-	-	-	23.7	50.5	25	117	20.0	34	25	117				
DN25	25	80	88	170	22.1	50.5	23.5	114.3	22.1	50.5	30	127	22.6	50.5	30	127	23	50.5	30	127	29.7	50.5	30	127	26.0	50.5	30	127
DN40	40	105	109	196	34.8	50.5	23	139.7	34.8	50.5	33	159	35.6	50.5	33	159	35.7	50.5	33	159	44.3	64	33.5	159	38.0	50.5	33.5	159
DN50	50	125	129	226	47.5	64	23	158.8	47.5	64	39	190	48.6	64	39	190	47.8	64	39	190	56.3	77.5	39	190	50.0	64	39	190
DN65	50	125	129	232	60.2	77.5	39	190	-	-	-	-	-	-	-	-	-	-	-	-	-	-	-	-	-			

Other specifications available for customization.

A01 Series
Welded Manual
Diaphragm Valve

A01 Series
Tri-clamp Manual
Diaphragm Valve



Order Instruction

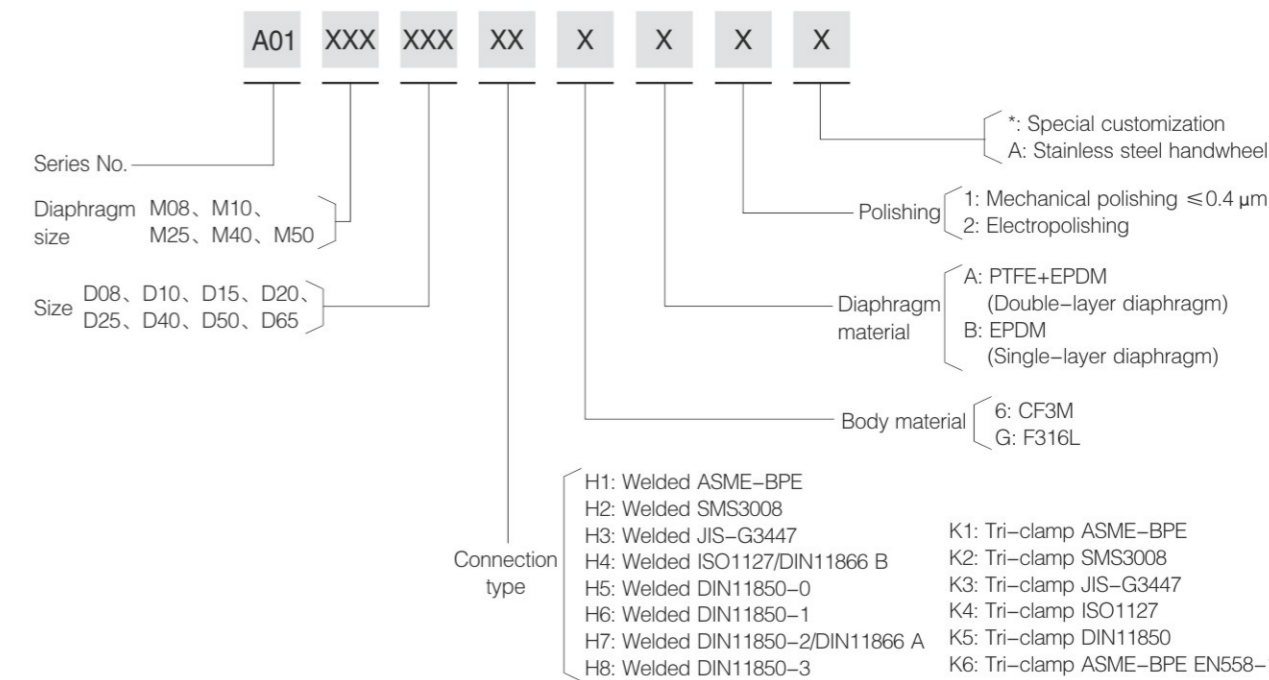

Diaphragm Valve

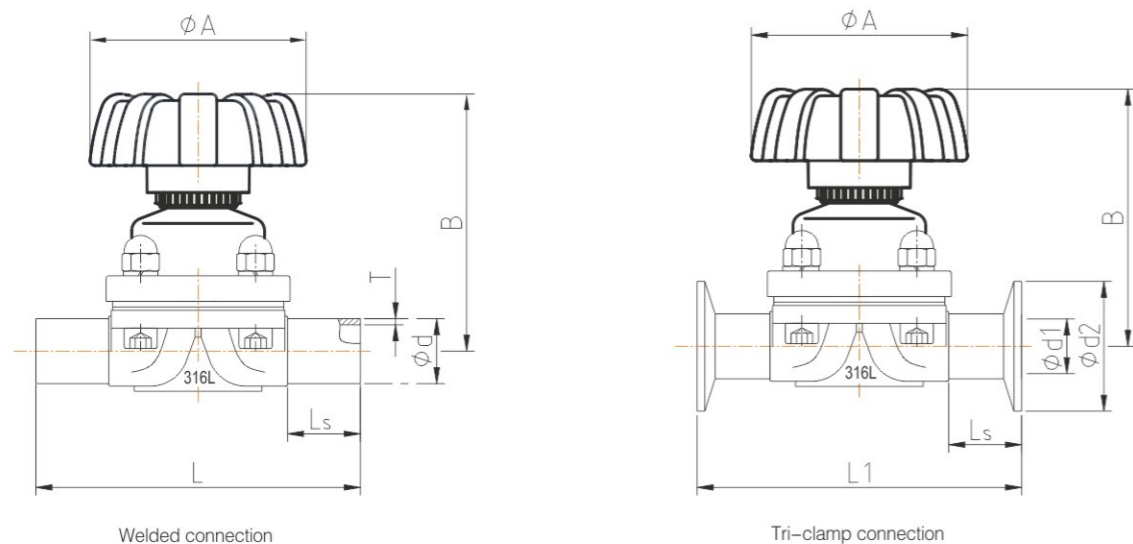

Main Dimension

Manual diaphragm valve -Weld connection					ASME-BPE	SMS3008	JIS-G3447	ISO-1127	DIN-11850				DIN-11866		
Size	Diaphragm	ΦA	B	Ls	L	Φd × T	Φd × T	Φd × T	Φd × T	-0	-1	-2	-3	A	B
DN8	8	40	64	20	72	6.35 × 0.89	-	-	-	-	-	-	-	-	-
DN10	8	40	64	20	72	9.53 × 0.89	-	-	-	-	-	-	-	-	-
DN15	8	50	64	17	72	12.70 × 1.65	-	-	-	-	-	-	-	-	-
	10	65	85	29.5	108	-	-	-	21.3 × 1.6	18 × 1.5	18 × 1.0	19 × 1.5	20 × 2	19 × 1.5	21.3 × 1.6
DN20	10	65	85	29.5	108	19.05 × 1.65	-	-	-	-	-	-	-	-	-
	25	85	102	26.5	120	-	-	-	26.9 × 1.6	22 × 1.5	22 × 1.0	23 × 1.5	24 × 2	23 × 1.5	26.9 × 1.6
DN25	25	85	102	26.5	120	25.4 × 1.65	25.0 × 1.2	25.4 × 1.2	33.7 × 2	28 × 1.5	28 × 1.0	29 × 1.5	30 × 2	29 × 1.5	33.7 × 2
DN40	40	105	115	30	153	38.1 × 1.65	38.0 × 1.2	38.1 × 1.2	48.3 × 2	40 × 1.5	40 × 1.0	41 × 1.5	43 × 2	41 × 1.5	48.3 × 2
DN50	50	125	133	30.5	173	50.8 × 1.65	51.0 × 1.2	50.8 × 1.5	60.3 × 2	52 × 1.5	52 × 1.0	53 × 1.5	54 × 2	53 × 1.5	60.3 × 2
DN65	50	125	139	30.5	173	63.5 × 1.65	-	-	-	-	-	-	-	-	-

Manual diaphragm valve -Tri-clamp connection					ASME-BPE		ASME-BPE EN558-1 Series 7				SMS3008		JIS-G3447		ISO-1127		DIN-11850										
Size	Diaphragm	ΦA	B	Φd1	Φd2	Ls	L1	Φd1	Φd2	Ls	L1	Φd1	Φd2	Ls	L1	Φd1	Φd2	Ls	L1	Φd1	Φd2	Ls	L1				
DN8	8	40	64	4.57	25	15.5	63.5	-	-	-	-	-	-	-	-	-	-	-	-	-	-	-	-	-			
DN10	8	40	64	7.75	25	15.5	63.5	-	-	-	-	-	-	-	-	-	-	-	-	-	-	-	-	-			
DN15	8	50	64	9.4	25	15.5	63.5	9.4	25	35	108	-	-	-	-	-	-	-	-	-	-	-	-	-			
	10	65	85	-	-	-	-	-	-	-	-	-	-	-	-	18.1	50.5	29.5	108	16.0	34	29.5	108				
DN20	10	65	85	15.75	25	26.3	101.6	15.75	25	34	117	15.75	25	34	117	-	-	-	-	-	-	-	-	-			
	25	85	102	-	-	-	-	-	-	-	-	-	-	-	-	23.7	50.5	25	117	20.0	34	25	117				
DN25	25	85	102	22.1	50.5	23.5	114.3	22.1	50.5	30	127	22.6	50.5	30	127	23	50.5	30	127	29.7	50.5	30	127	26.0	50.5	30	127
DN40	40	105	115	34.8	50.5	23	139.7	34.8	50.5	33	159	35.6	50.5	33	159	35.7	50.5	33	159	44.3	64	33.5	159	38.0	50.5	33.5	159
DN50	50	125	133	47.5	64	23	158.8	47.5	64	39	190	48.6	64	39	190	47.8	64	39	190	56.3	77.5	39	190	50.0	64	39	190
DN65	50	125	139	60.2	77.5	39	190	-	-	-	-	-	-	-	-	-	-	-	-	-	-	-	-	-	-		

Other specifications available for customization.

Proportional Diaphragm Valve

A02 Series
Proportional
Diaphragm Valve



Technical Specification

- Voltage: 24V DC
- Power: <4W
- Input signal: 0/4–20mA, 0–5/10V
- Output signal: Analog signal (0/4–20mA, 0–5/10V)
Digital signal (High voltage level)
(Alternative choice of two)
- Enclosure material: PA6-GF15+PC+304
- Control pressure: 4.5–7bar (65–102psi)
- Ambient temperature: 0–60°C
- Protection level: IP65
- Explosion-proof: II 3G Ex ec IIC T4 Gc

Advantages

1. Compact size to save space.
2. Reliable performance and sensitive reaction.
3. Large LCD display makes it easy to operate.
4. Standard electrical interface allows convenient wiring.
5. High adjustment precision and strong anti-interference performance.
6. Spring-loaded feedback rod for easy installation.
7. Allows various types of connection interface.

Function Principle

Intelligent positioner is a microprocessor-based valve regulator. The valve's open/close state is controlled by external input signals. It is widely used in industrial fluids control systems in order to enable remote and automated control.

Proportional Diaphragm Valve

Electrical Terminal

Electrical Terminal	Descriptions	Color	Signal Type
1	Power+	Brown	+24VDC ± 10%
2	Input Signal+	White	0/4–20mA or 0–5/10V
3	Common Ground Wire(GND)	Blue	GND
4	Feedback Signal+ (Optional: Alarm output for insufficient adjustment)	Black	0/4–20mA or 0–5/10V (High electric level)
5	Standby	Grey

Pneumatic Terminal

Port Label	Description
P	Air supply port
A	Control port
R	Exhaust port

Order Instruction

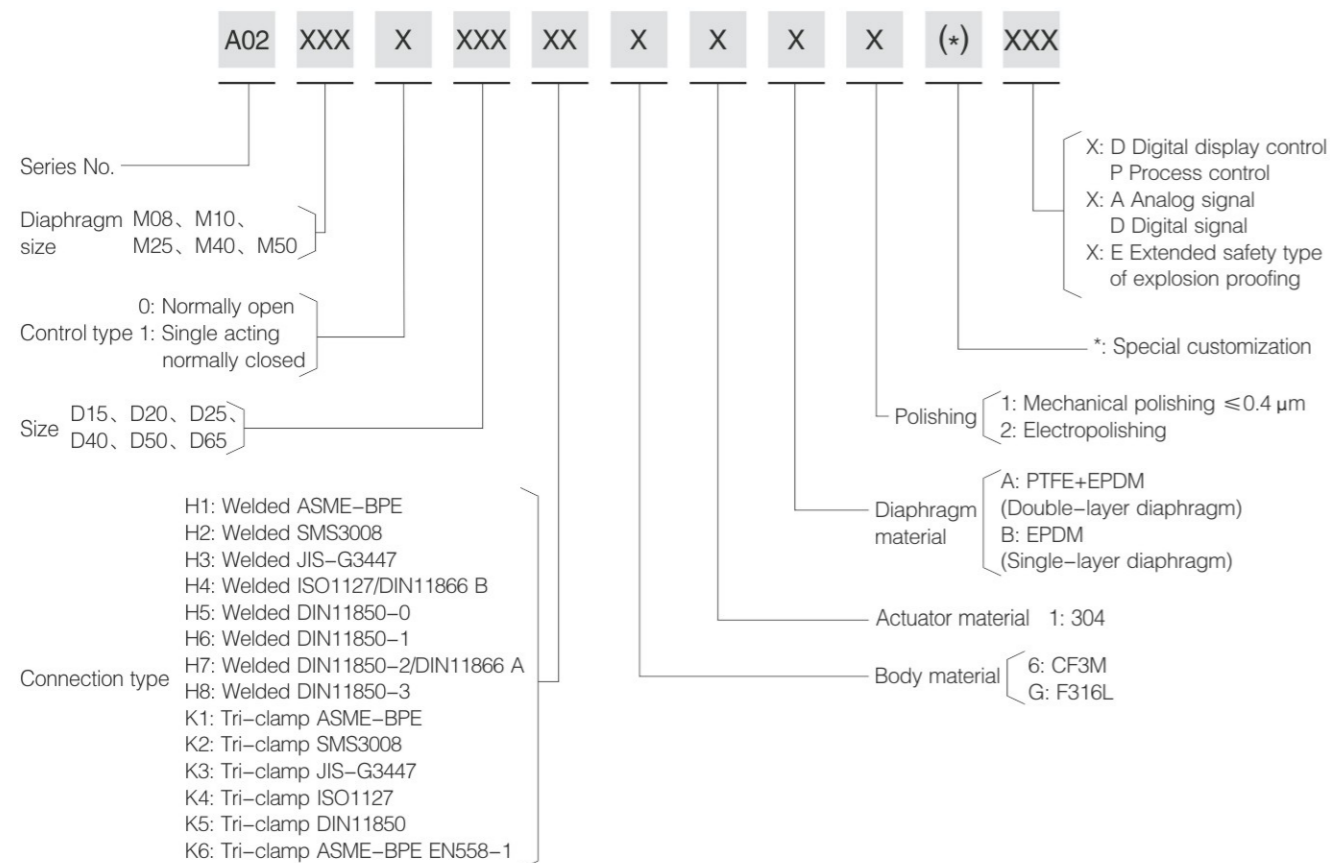

T-Shape Valve

A10 Series
Pneumatic
T-shape Valve



A11 Series
Manual
T-shape Valve



Technical Specification

- Material: Investment casting CF3M, Forged F316L (Customized special materials)
(Pneumatic) Actuator+Valve seat CF8;
(Manual) Valve seat CF8
- Internal Surface: Ra≤0.4 μm mechanically polished
- Diaphragm Material: EPDM+PTFE (Double-layer diaphragm)
EPDM (Single-layer diaphragm)
- Operating Pressure: 0–10bar (0–145psi)
- Fluid Temperature: –10°C — +130°C (sterilization at 150°C for 60mins)
- Control Pressure(pneumatic): 4.5–7bar (65–102psi)

Advantages

1. Compact structure to minimize installation space.
2. No dead angle and auto emptying can be achieved based on the installation position.
3. Applicable to CIP/SIP process to actualize online high temperature disinfection.
4. The surface finish of the inner surface of the valve body can reach Ra0.4.
5. Manual and pneumatic actuator is optional.
6. According to 3D standards, it can be placed vertically.

Function Principle

The T-shape valve body is welded to the annular lines of liquid or pure water system. Through this technical method, it can achieve the best effect of sampling or usage of water seamlessly. In addition, based on the requirement of the process, the technology is able to mix two kinds of working mediums. Most importantly, the seal ridge of the T-shape valve has to be as close to the main pipe as possible.

Order Instruction

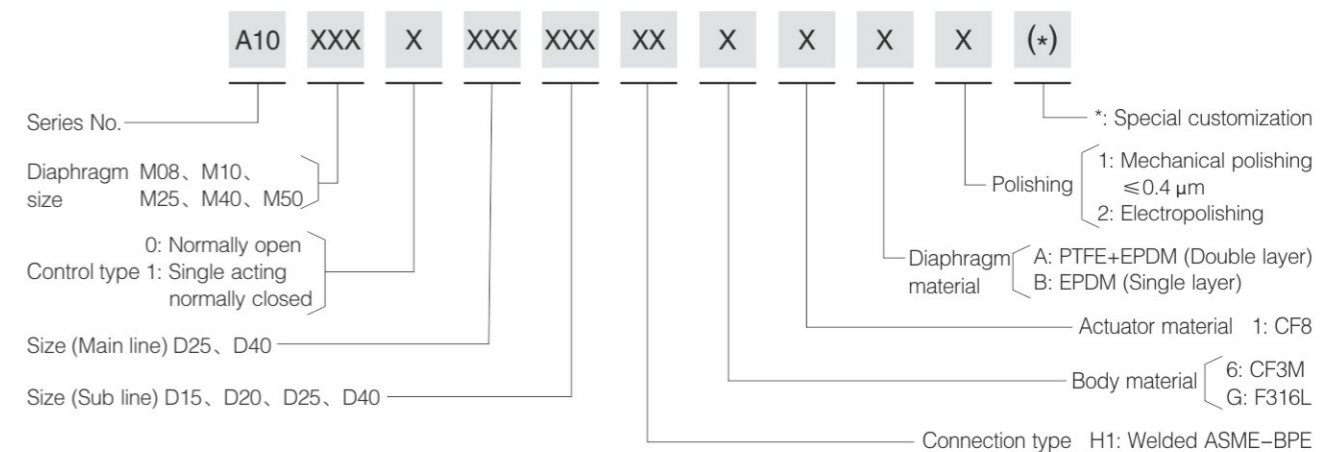

T-Shape Valve

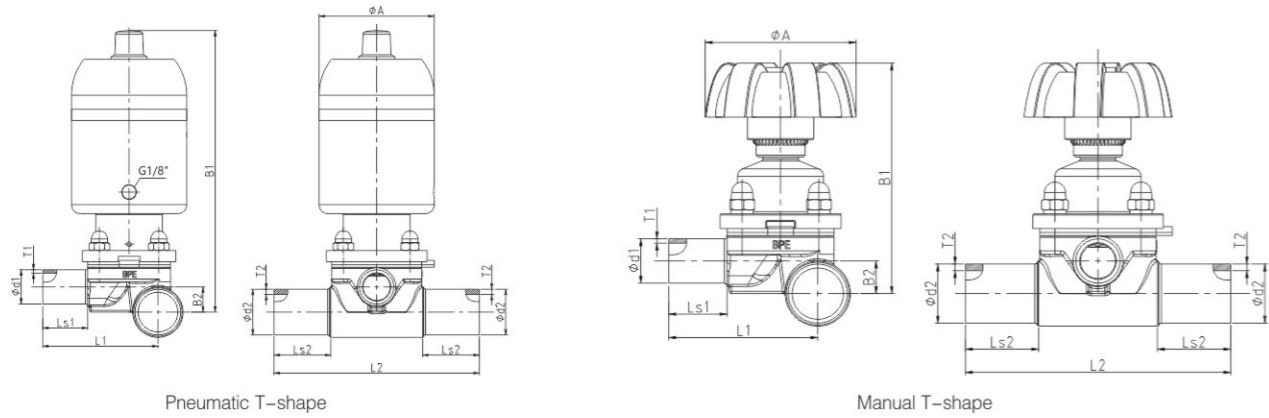

Main Dimension

Pneumatic T-shape Valve — Welded Connection										ASME-BPE	
Size	Diaphragm	Actuator	Φ A	B1	B2	Ls1	Ls2	L1	L2	Φ d1 X T1	Φ d2 X T2
25-15	8	50	57	140	15	20	33	51	103	12.7 X 1.65	25.4 X 1.65
25-20	10	57	65	165	14	25	31	64	114	19.05 X 1.65	25.4 X 1.65
25-25	25	80	88	205	13	25	25	76	124.5	25.4 X 1.65	25.4 X 1.65
40-25	25	80	88	215	20	25	25	82	124.5	25.4 X 1.65	38.1 X 1.65
40-40	40	105	109	235	20	25	27	97.5	152	38.1 X 1.65	38.1 X 1.65

Manual T-shape Valve — Welded Connection										ASME-BPE	
Size	Diaphragm	Φ A	B1	B2	Ls1	Ls2	L1	L2	Φ d1 X T1	Φ d2 X T2	
25-15	8	50	80	15	20	33	51	103	12.7 X 1.65	25.4 X 1.65	
25-20	10	65	100	14	25	31	64	114	19.05 X 1.65	25.4 X 1.65	
25-25	25	85	115	13	25	25	76	124.5	25.4 X 1.65	25.4 X 1.65	
40-25	25	85	125	20	25	25	82	124.5	25.4 X 1.65	38.1 X 1.65	
40-40	40	105	130	20	25	27	97.5	152	38.1 X 1.65	38.1 X 1.65	

Order Instruction

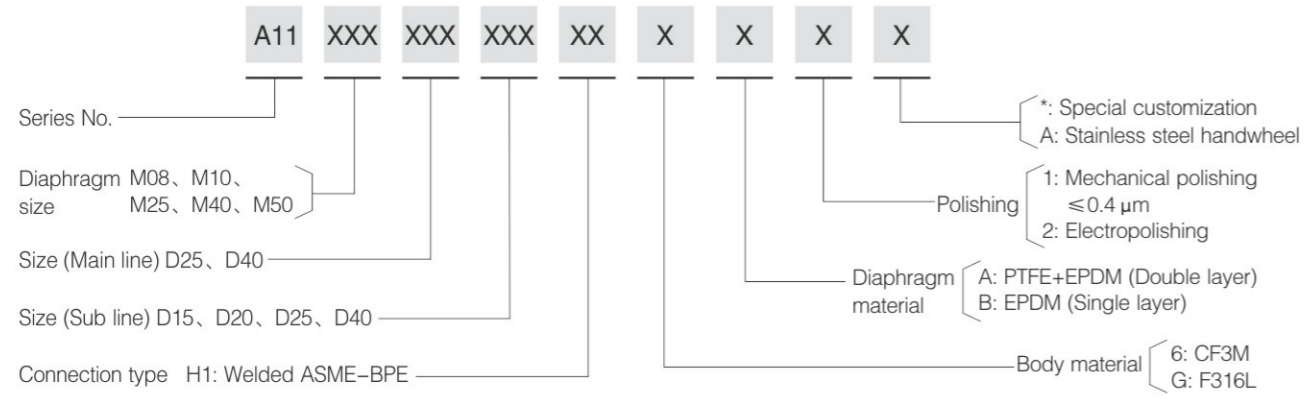

Tank Bottom Valve

A20 Series
Pneumatic Tank
Bottom Diaphragm

A21 Series
Manual Tank
Bottom Diaphragm



Technical Specification

- Material: Investment casting CF3M, Forged F316L (Customized special materials) (Pneumatic) Actuator+Valve seat CF8; (Manual) Valve seat CF8
- Internal Surface: Ra≤0.4 μm mechanically polished
- Diaphragm Material: EPDM+PTFE (Double-layer diaphragm) EPDM (Single-layer diaphragm)
- Operating Pressure: 0-10bar (0-145psi)
- Fluid Temperature: -10°C — +130°C (sterilization at 150°C for 60mins)
- Control Pressure(pneumatic): 4.5-7bar (65-102psi)

Advantages

1. Compact structure to minimize installation space.
2. No dead angle, auto emptying and no turbulence phenomenon during the emptying process.
3. Applicable to CIP/SIP process to actualize online high temperature disinfection.
4. The surface finish of the inner surface of the valve body can reach Ra0.4.
5. Manual and pneumatic actuator is optional.

Function Principle

The bottom valve of the tank is welded to the bottom of the container to achieve the best effect of emptying, cleaning and disinfection. In addition, the working medium can be well mixed according to various technological requirements during the operation. The most important thing is that the sealing weir of the tank bottom valve has been close to the tank bottom wall to the greatest extent, so as to achieve the effect of zero dead angle.

Order Instruction

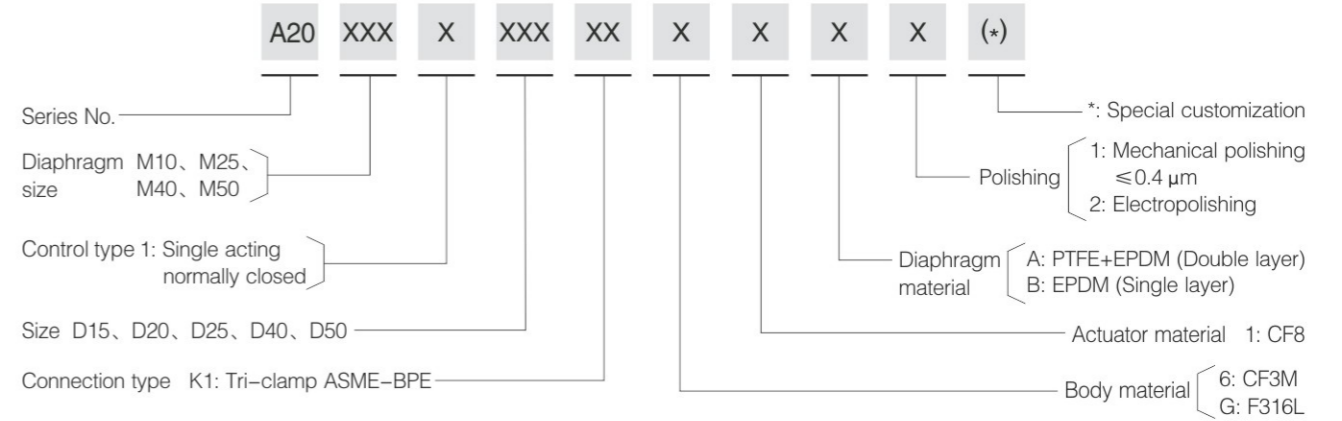

Tank Bottom Valve

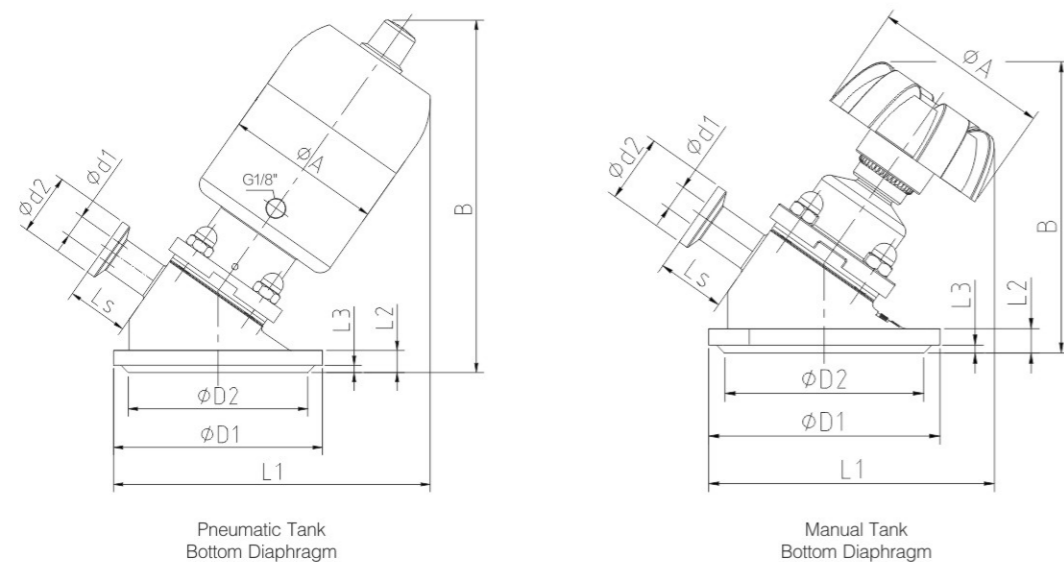

Pneumatic Tank Bottom Diaphragm

Manual Tank Bottom Diaphragm

Main Dimension (Pneumatic Tank Bottom Valve)

Size	Diaphragm	ϕA	B	$\phi D1$	$\phi D2$	$\phi d1$	$\phi d2$	L1	L2	L3	Ls
DN15	10	65	145	85	73	9.4	25	130	12	3	25
DN20	10	65	145	85	73	15.75	25	130	12	3	25
DN25	25	88	195	120	108	22.1	50.5	178	16	3	30
DN40	40	109	220	150	138	34.8	50.5	210	18	3	35
DN50	50	129	255	180	168	47.5	64	240	22	3	35

Main Dimension (Manual Tank Bottom Valve)

Size	Diaphragm	ϕA	B	$\phi D1$	$\phi D2$	$\phi d1$	$\phi d2$	L1	L2	L3	Ls
DN15	10	65	110	85	73	9.4	25	105	12	3	25
DN20	10	65	110	85	73	15.75	25	105	12	3	25
DN25	25	85	135	120	108	22.1	50.5	138	16	3	30
DN40	40	105	155	150	138	34.8	50.5	165	18	3	35
DN50	50	125	180	180	168	47.5	64	195	22	3	35

Order Instruction

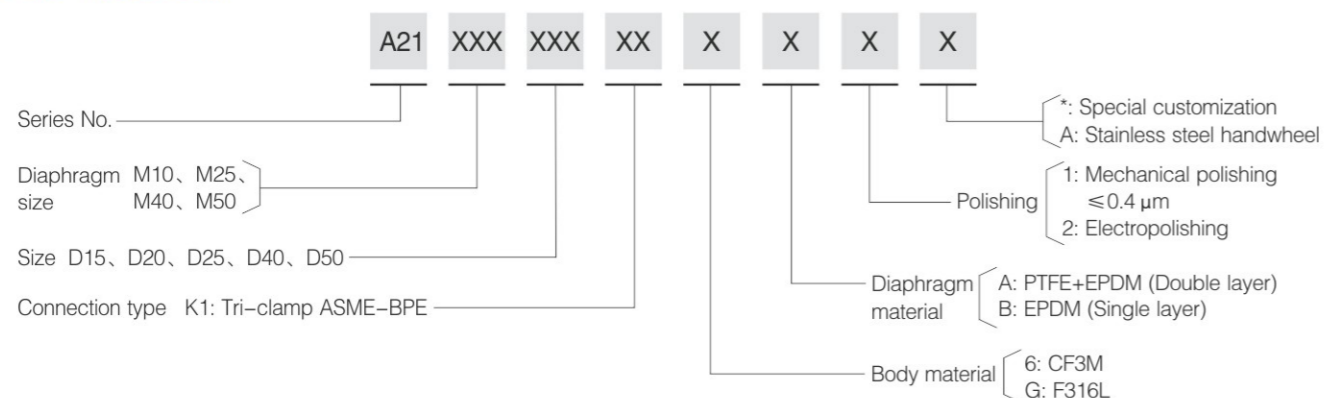

Sampling Valve

A31 Series Single Port Manual Sampling Valve



Welded Connection

Tri-clamp Connection

A31 Series Dual-Port Manual Aseptic Sampling Valve



Welded Connection

Tri-clamp Connection

Technical Specification

- Valve Body Material: AISI 316L
- Internal Surface: Mechanical Polishing $Ra \leq 0.4 \mu m$; Electropolishing
- Connect Type: Welded Connection, Clamp Connection
- Valve Body Bore Diameter: $\phi 8$
- Nominal Pressure: PN16
- Control Type: Manual
- Connection Type: ASME-BPE Welded, ASME-BPE Clamp
- Diaphragm Material: PTFE
- Operating Pressure: 0–1.0Mpa
- Fluid Temperature: $-10^{\circ}C$ — $+150^{\circ}C$
- Structure: Single Port (With Sterilization Function), Dual-Port

Advantages

- Valve diaphragm is certified with FDA and USP.
- Valve bodies with ports are machined in one piece of forging steel, thus avoiding all crevices and fissures from welded or screwed parts.
- Valve bodies come with welded or clamp connection, customization is acceptable.
- Sanitary seal has good resistance to high pressure, excellent corrosion resistance and is of long service life.
- Spring-preloading structure strengthens sealing effect and prolong the valve seat service life.

Order Instruction

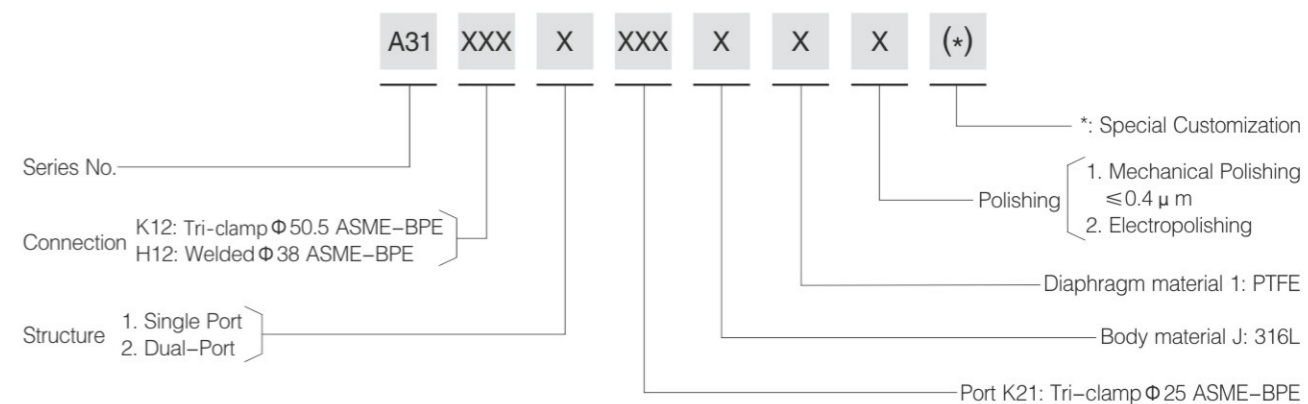

Sampling Valve

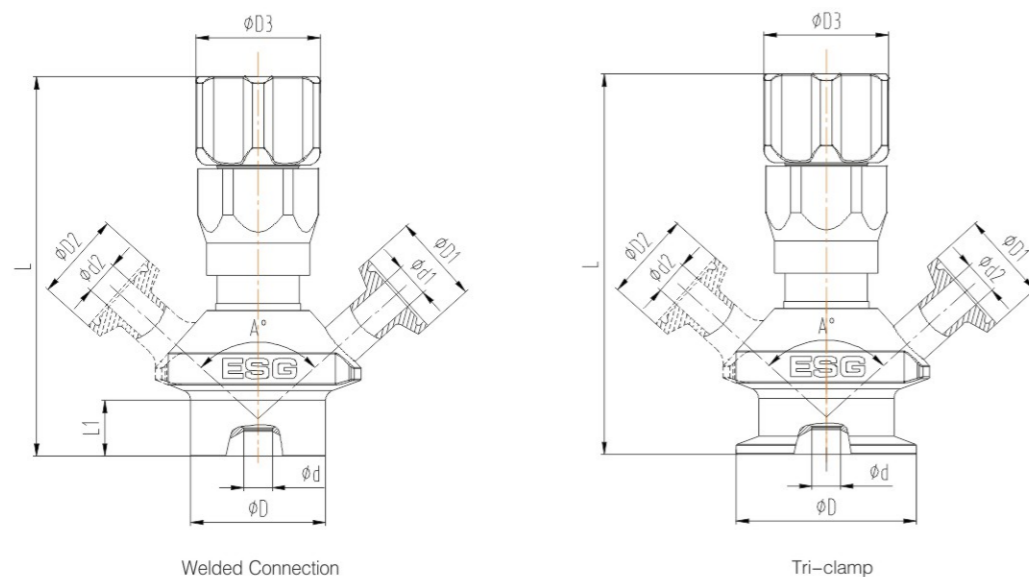

Main Dimension (Tri-clamp Connection)

Size	ΦD	Φd	L	ΦD1	Φd1	ΦD2	Φd2	ΦD3	A°
Single Port	50.5	8	110	25	9.4	–	–	38	96
Dual-Port	50.5	8	110	25	9.4	25	9.4	38	96

Port size customization available.

Main Dimension (Welded Connection)

Size	ΦD	Φd	L	L1	ΦD1	Φd1	ΦD2	Φd2	ΦD3	A°
Single-Port	38	8	110	15.5	25	9.4	–	–	38	96
Dual-Port	38	8	110	15.5	25	9.4	25	9.4	38	96

Port size customization available.

Multi-port Valve Block

A4 Series
i – bodies



Advantages

I-bodies valve is a special structural form based on two two-way, two-position valves. The absence of welding processes between the two valves ensures the safety of production. The ESG I-body valve body adopts an integrated steel one-piece processing valve body, which has the following advantages:

1. Compact design and light weight;
2. Minimization of dead corners;
3. No welding inside the valve body;
4. Compact installation;
5. Cost saving;
6. It can be placed vertically according to 3D standards;
7. It has better drainage capacity than combined valves;
8. The valve seat can be equipped with either a pneumatic or a manual actuator.

Multi-port Valve Block

A6 Series
M - bodies



Overview

For this series, based on the actual needs on site, ESG conducts the design after fully understanding the detailed working conditions of customers, such as their usage processes, installation positions and the flow relationships among various valves. During the design process, the cleaning, sterilization, emptying performance, dead corners and residues of the valves are taken into consideration. ESG designers present the optimal and most reasonable designs to customers.

Advantages

1. Customized design according to requirements.
2. CNC machining of integral steel.
3. Compact structure.
4. No dead corners and automatic emptying.
5. Convenient installation.
6. Shorten the commissioning time.
7. Improve the safety of production.
8. Free choice between manual and pneumatic actuators.

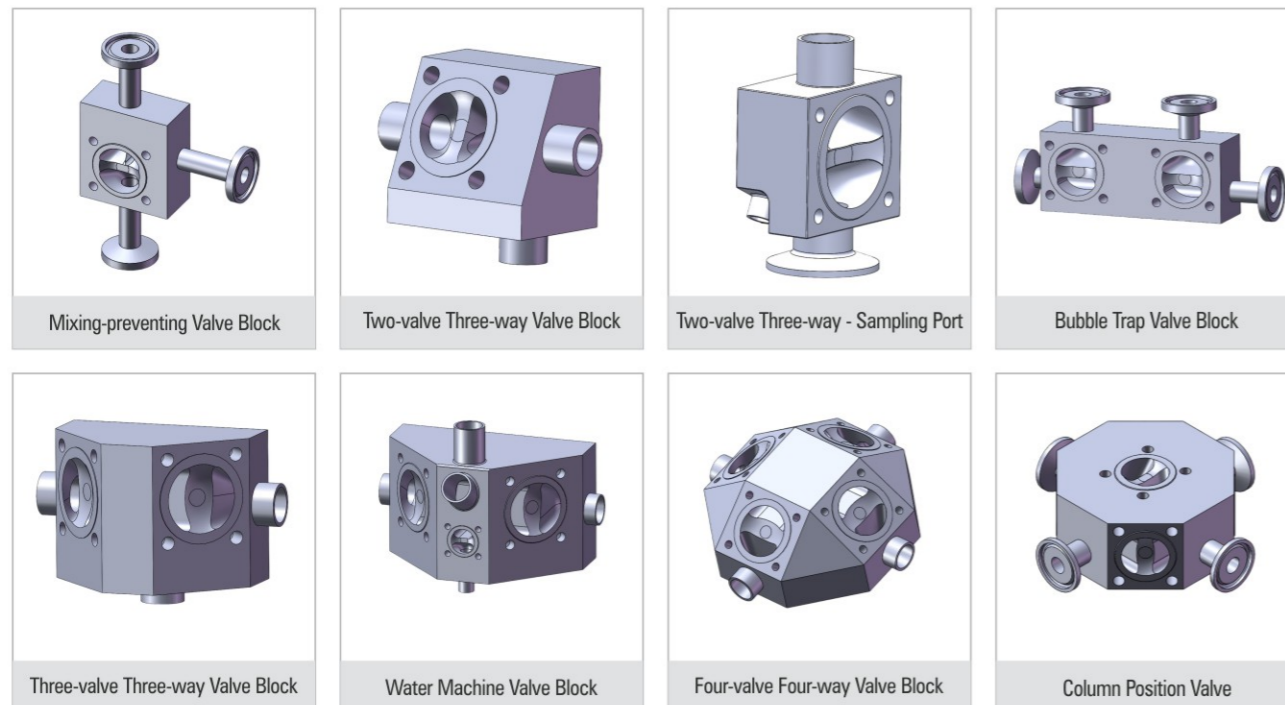

Combination Valve

A50 series
Combination
Diaphragm Valve

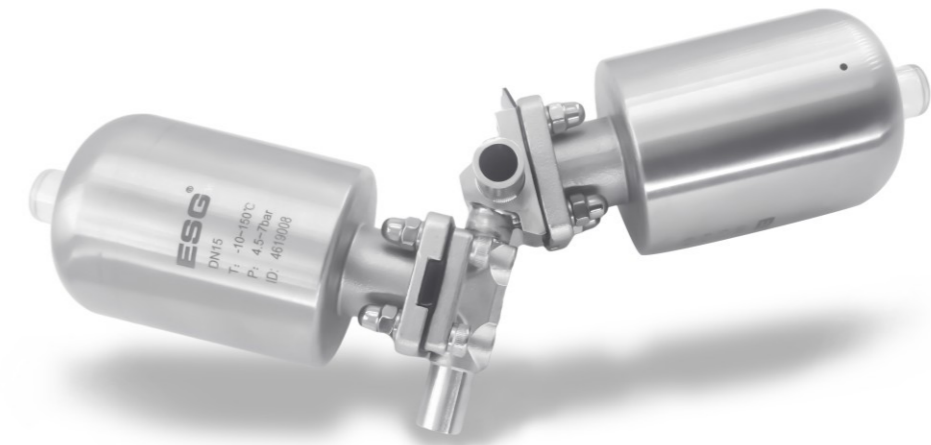

Overview

In order to better balance the material costs and processing costs, on the premise of meeting the customer's process requirements such as cleaning, sterilization, and self-discharging, ESG has carried out specific arrangements and layouts for the valves, thus obtaining the most reasonable solutions for customers to use. The GMP combination valve combines two two-way diaphragm valves or combines one two-way diaphragm valve and a tri-clamp chuck by means of welding. According to the application situation in the industry, ESG has launched 10 GMP combination modes for customers to choose from. For working conditions with higher requirements for the effects of cleaning, sterilization, self-discharging, etc., customers often need two two-way diaphragm valves to not only meet the requirements of self-discharging or full-discharging but also minimize the dead corners at the connection points as much as possible. To this end, ESG has launched 8 SAP combination modes and 4 SAP two-way valves with a third outlet interface for customers to choose from. The valve body material of the combination valve can be freely combined according to the needs of customers, and the combination form can also be specially customized according to the customer's process requirements.

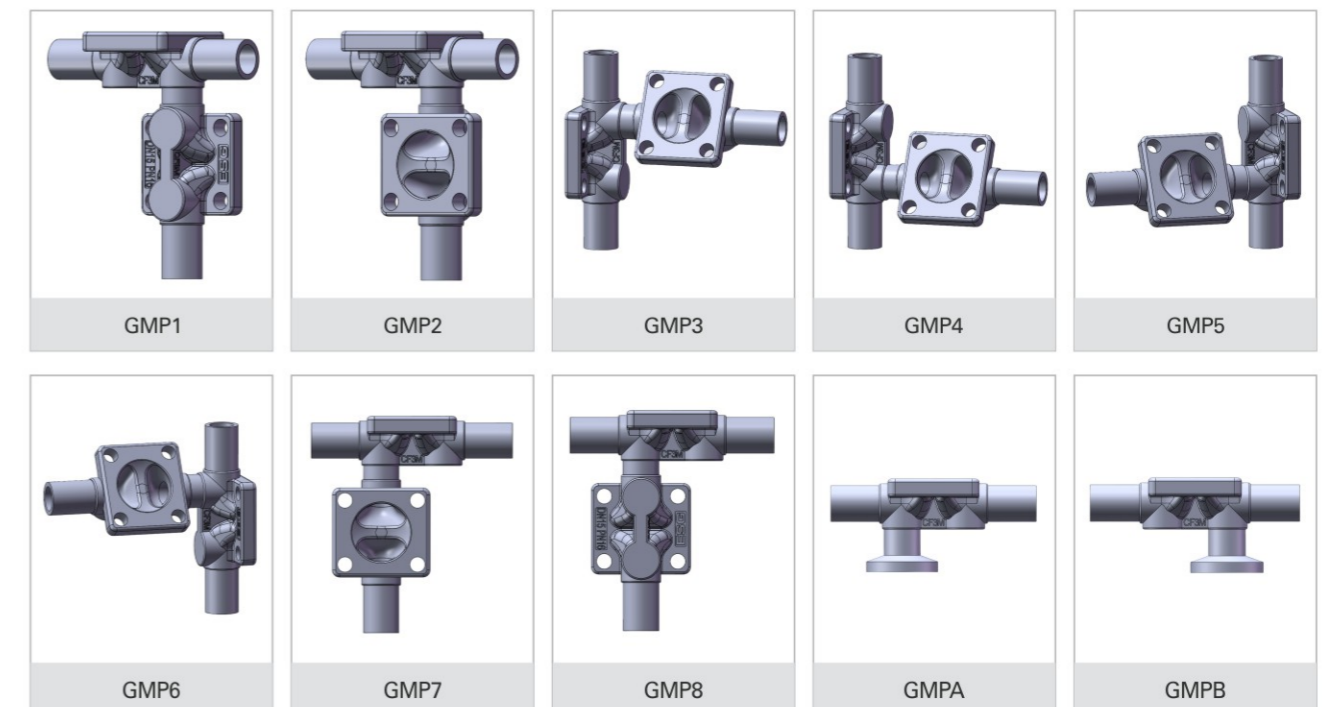

Combination Valve



Order Instruction

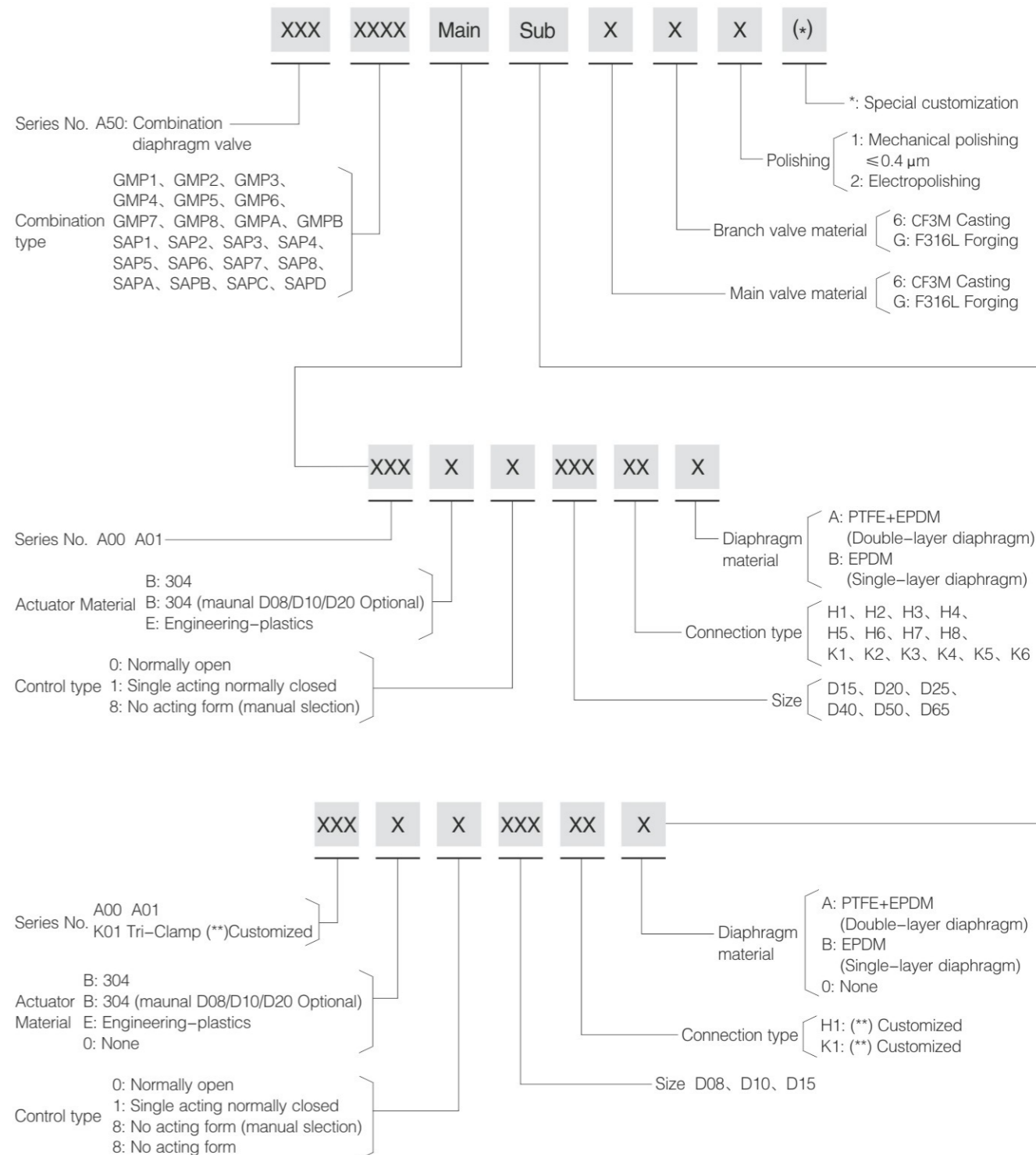

Combination Valve

A52 series
Combination Bottom
Tank Valve

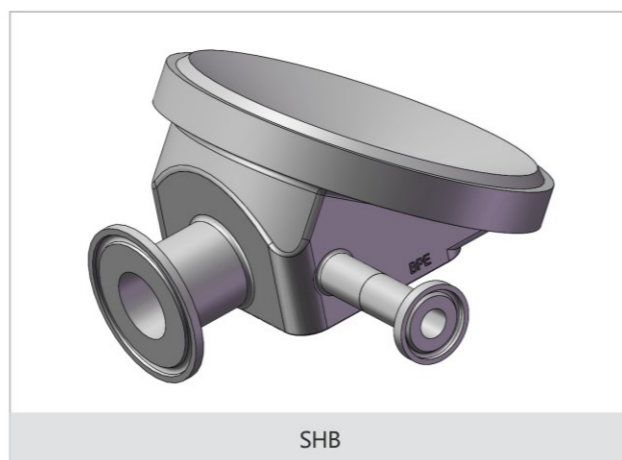
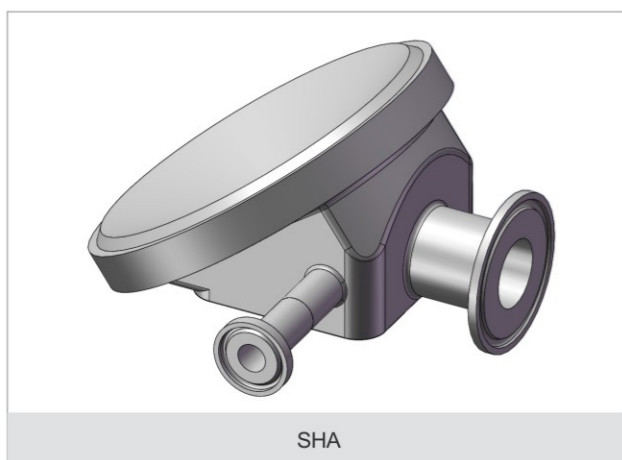
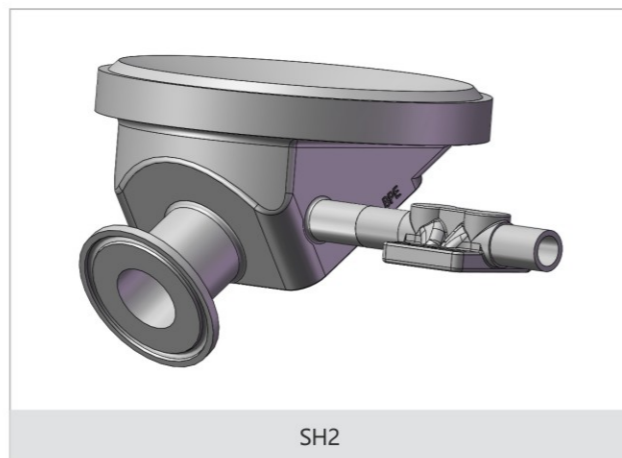

Overview

In order to take into account the manufacturing cost under the premise of meeting client's requirement during cleaning process, sterilization process and self discharge abilities, ESG has specifically arranged the layout of the valve so to provide the most suitable scheme for our client.

Bottom tank valve can be equipped with CIP/SIP interface at the rear of the valve body, the interface can be optionally chucked or welded to connect the pipe or the valve body. ESG can combine both tank bottom valve and two-way diaphragm valve, or reserve the side wall of the bottom tank valve for welding and chuck interfaces for CIP/SIP process. The following combinations is available and combinations can be customized according to requirements.

Order Instruction

