

# 3/2 DIRECT ACTING, HIGH ORIFICE UNIVERSAL SUBBASE MOUNTED SOLENOID VALVE

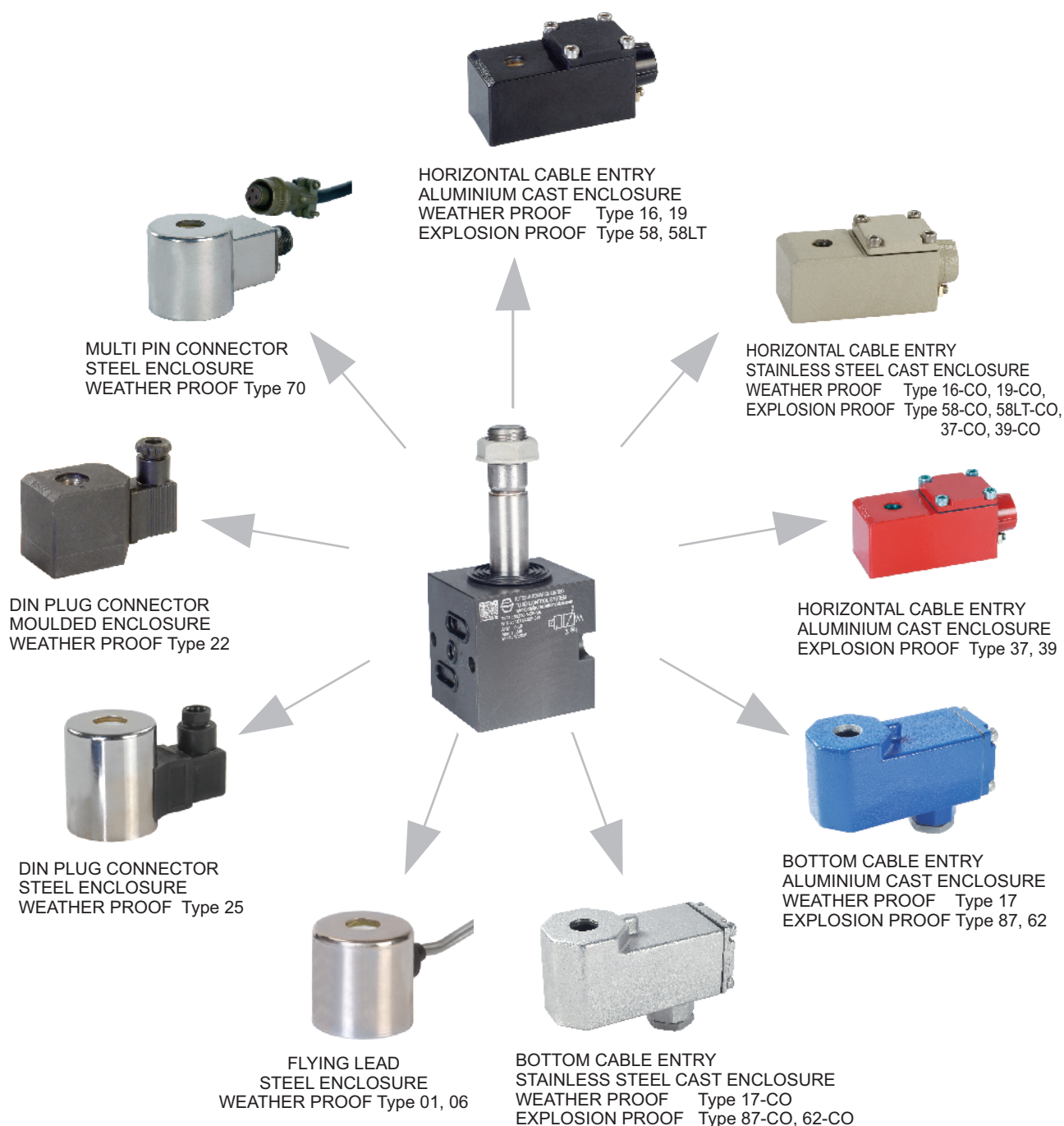

**Interchangeable across  
Voltage/ Current range without  
affecting performance of the Valve**

**3/2 DIRECT ACTING, HIGH ORIFICE UNIVERSAL SUBBASE MOUNTED SOLENOID VALVE**

**FEATURES**

- Bubble tight shut OFF
- Mounts in any position
- Suitable for Vacuum up to 10<sup>-6</sup> torr
- Vibration resistance up to 9g
- Suitable for high speed cycling, speed up to 900 cycles/ min
- Life >20 million cycles

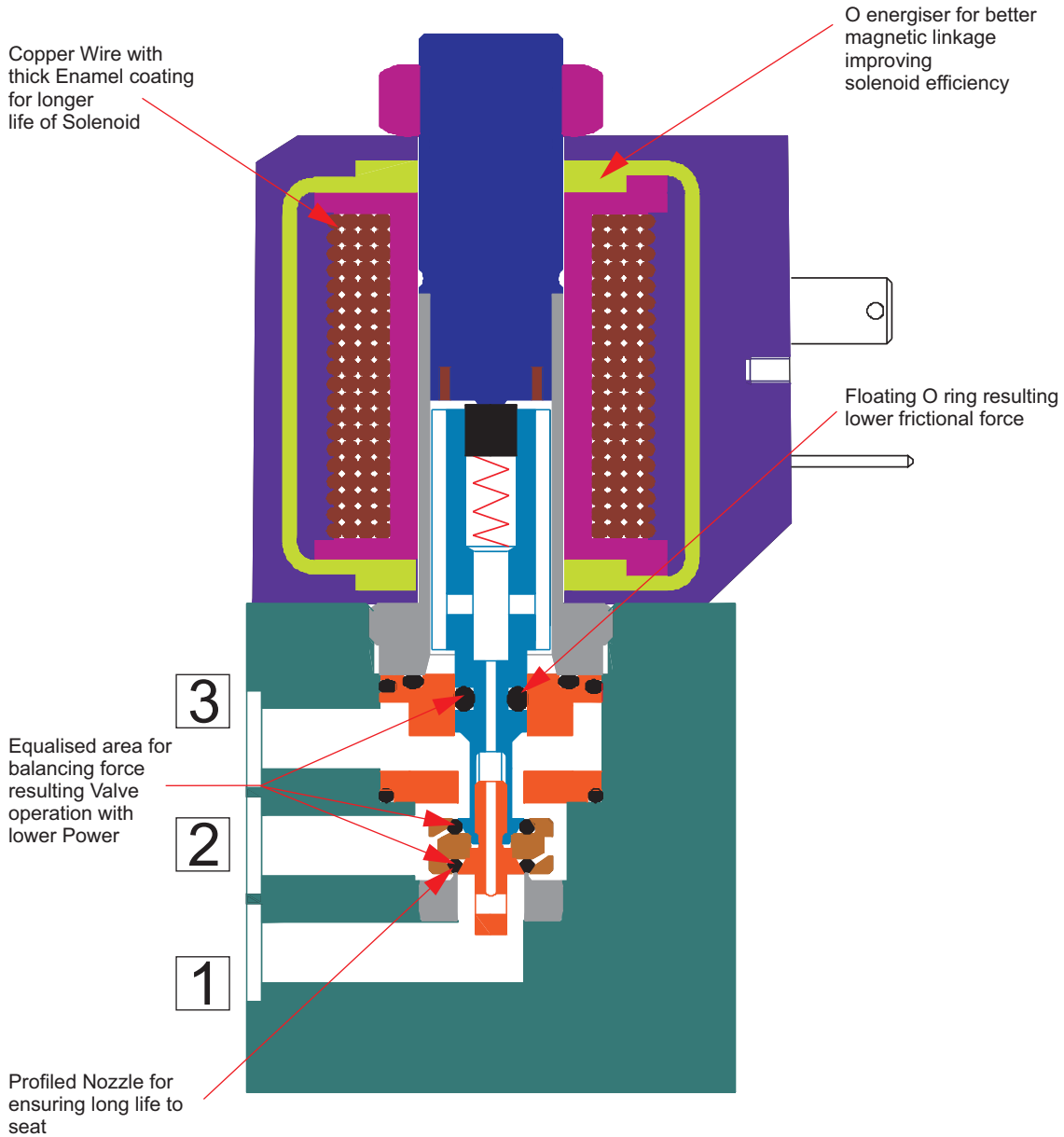

**WEIGHT IN kg. (Appx.)**

**Valve**

Model - Orifice	Al	SS
30316-5, P3014-5	0.40	0.70
30317-7, 30332-7	0.60	1.20
30317V01-10, 30332-10	0.90	2.00

**Solenoid**

Type	Size		Type	Size	Enclosure	
					Al	SS
01, 06	I	0.25	16, 19,	I	0.55	1.20
	II	0.45	37, 39,	II, IV	0.85	1.70
22	I	0.25	58, 58LT	III	0.60	1.50
25	II	0.45	17, 62,	II, IV	1.00	1.65
	III	0.40	87	III	0.90	1.50
	IV	0.50				

**VOLTAGE VARIATION**

(For Continuous Duty)

Rated Voltage	Operating Voltage
6	4.8V to 7.2V
12	9.6V to 14.4V
24	19.2V to 28.8V
48	38.4V to 57.6V
110 to 120	88V to 132V
220/ 230/ 240	176V to 264V
256	205V to 280V

**SERIES : 32D**

**3/2 DIRECT ACTING, HIGH ORIFICE UNIVERSAL SUBBASE MOUNTED SOLENOID VALVE**

TYPE	PRESSURE
30316LW	0 - 10 bar
30316	0 - 10 bar
30317	0 - 10 bar
30332	0 - 16 bar
P3014	0 - 10 bar

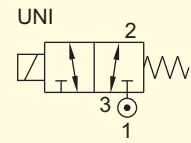

**WETTED PARTS**

Code	※	B5
<b>Body</b>	Anodized Aluminium	SS 316
<b>Internals</b>	Aluminium, Brass and SS 316	SS 316
<b>Guide</b>	SS 304	
<b>Shadow-Ring</b>	Copper/ None	
<b>Plunger, Insert</b>	SS 430	
<b>Spring</b>	SS 302	
<b>Fasteners</b>	SS 304	
<b>Seat, Seals</b>	NBR, Viton	



**APPLICATION**

Actuator/ Cylinder/ Control Valve actuation,  
Mixing/ Diverting application

**POWER**

Power	Normal		Low			Ex ia
	15W/ 20W	8W	3.5 W	1.8W	1W	Type 62
Type	30317 30332	30316	P3014	30316LW	30316LW	30316LW
Size	II	I/ III	III	IV	IV	IV

**SPARES**

SPARE KIT	CODE
<b>Seal Kit</b> : Oring Set and Plunger assembly	98
<b>Repair Kit</b> : All Components except Body, Cover and Solenoid	99
<b>Solenoid Kit</b> : Solenoid, Gasket and Nut	34

**PORT CONNECTION**

VALVE TYPE	MODE	INLET	OUTLET	EXHAUST
30316, 30317	<b>NC</b>	1	2	3
30332, 30316LW,	<b>NO</b>	3	2	1
P3014	<b>Mixing</b>	1 & 3	2	
	<b>Diverting</b>	2	1 & 3	

Contact Rotex for  
• Any other Temperature Range, Media and Application

**3/2 DIRECT ACTING, HIGH ORIFICE UNIVERSAL SUBBASE MOUNTED SOLENOID VALVE**

**SPECIFICATION**

VALVE		SOLENOID	
Valve Type	3/2 Direct Acting, High Orifice Universal Subbase mounted Solenoid valve	Voltage-Current	DC 12V, 24V, 48V, 110V, 220V, 256V
Body Material	Aluminium/ Stainless Steel 316		AC/ DC (50Hz/ 60Hz/ DC) 24V, 110V, 120V, 230V, 240V
Port Connection	Subbase	Power	20W/ 15W/ 8W/ 3.5W/ 1.8W/ 1W
Orifice	5mm/ 7mm/ 10mm	Protection	Weather Proof IP 67/ IP 68 Explosion Proof Ex d, Ex ia, Ex e mb IIC T6/ T5/ T4 IP67
Seals	NBR/ Viton GLT	Cable Entry	Pg 9 / M20X1.5/ 1/2" NPT/ M25X1.5
Manual Override	Stayput/ Momentary/ Without Manual Override	Accessories	Sub base Orings & Fasteners for mounting Solenoid Valve supplied loose
Flow factor Orifice-kv/ Kv/ Cv	5mm-8/ 0.48/ 0.56 7mm:- 14/ 0.84/ 0.98 10mm:- 30/ 1.8/ 2.1		
Media	Air, Diesel, Hydraulic Oil, Inert Gas, Kerosene, LPG, Lubrication Oil, Petrol (Motor Spirit), Turbine Oil, Water		
⑬ Ambient, Fluid Temperature	-25 °C to 75 °C, Optionally -40 °C to 150 °C		
Response ON/ OFF	≤ 12ms/ ≤ 12ms		
Pressure	0-10 bar, 0-16 bar		

**ORDERING CODE Solenoid Valve (Valve Code + Solenoid Code)**

VALVE TYPE 30316	-	SIL SL	-	SUFFIX SO	-	ORIFICE 5	-	PORT CONNECTION SB	-	BODY INTERNAL B5	-	MANUAL OVERRIDE M8	-	SEAL S2G	-	⑫ MEDIA *
ACCESSORIES VALVE, PORT A4-C4	+	SIZE III	-	VOLTAGE, CURRENT 24V DC	-	ENCLOSURE 19	-	⑦ MTL *	-	SPECIAL SS	-	POWER *	-	INSULATION H	-	APPROVAL CE
SIL SL	-	ACCESSORIES SOLENOID B8														

**ORDERING CODE Valve Spare Kit**

SPARE KIT 99	-	VALVE TYPE 30316	-	SIL SL	-	SUFFIX SO	-	ORIFICE 5	-	PORT CONNECTION SB	-	BODY INTERNAL B5	-	MANUAL OVERRIDE M8
SEAL S2G	-	ACCESSORIES VALVE, PORT A4-C4												

**ORDERING CODE Spare Solenoid**

SOLENOID KIT 34	-	SIZE III	-	VOLTAGE, CURRENT 24V DC	-	ENCLOSURE 19	-	⑦ MTL *	-	SPECIAL SS	-	POWER *	-	INSULATION H	-	APPROVAL CE
SIL SL	-	ACCESSORIES SOLENOID B8														

**ORDERING CODE Manifold**

MANIFOLD TYPE MF005 MF017	-	SPACE 6	-	PORT CONNECTION * BSP R NPT	-	MANIFOLD MATERIAL * ALUMINIUM	-	ACCESSORIES Refer to Valve Accessories on page 9 and 10	-	* VALVE CODE 30316 30316LW P3014 30317-7 30332-7 30317V01-10 30332-10	-	NUMBER OF VALVE 5
MF006 MF044												
MF007 MF018												

SOLENOID CODE Specify Solenoid Code, (refer to pages 5 & 6)	-	ACCESSORIES SOLENOID Refer to Solenoid Accessories on page 9
--	---	---

\* Specify complete Valve Code refer to page 5.

**3/2 DIRECT ACTING, HIGH ORIFICE UNIVERSAL SUBBASE MOUNTED SOLENOID VALVE**

VALVE TYPE-ORIFICE	
CODE	DESCRIPTION
<b>NORMAL POWER</b>	
30316-5	0-10 bar, 8 Watt, Size I, III
30317-7	0-10 bar, 15/ 20 Watt, Size II
30317V01-10	0-10 bar, 15/ 20 Watt, Size II
30332-7	0-16 bar, 15/ 20 Watt, Size II
30332-10	0-16 bar, 15/ 20 Watt, Size II
<b>LOW POWER</b>	
P3014-5	0-10 bar, 3.5 Watt, Size III
30316LW-5	0-10 bar, 1.8 Watt, Size IV
30316LW-5	0-10 bar, 1.0 Watt, Size IV, LW1 Enclosure Type 17 or 87
<b>INTRINSICALLY SAFE Ex ia 24V DC</b>	
30316LW-5	0-10 bar, Enclosure Type 62, Size IV

SIL CERTIFIED	
CODE	DESCRIPTION
① ✖	NO
SL	YES

SUFFIX	
CODE	DESCRIPTION
① ✖	NIL
⑧ AM	Ammonia
⑧ SO	Anti Corrosive Operator
OX	Oxygen Capable
⑱ TC	2 Port Bi Directional NC
⑱ TO	2 Port Bi Directional NO

PORT CONNECTION	
CODE	DESCRIPTION
SB	Subbase

BODY MATERIAL	
CODE	DESCRIPTION
① ✖	Aluminium
B5	SS316
B5N	SS316 NACE Compliance

MANUAL OVERRIDE	
CODE	DESCRIPTION
① ✖	NIL
M6	Stayput
M8	Momentary

SEAL		MEDIA			
CODE	GRADE, AMBIENT/ FLUID TEMPERATURE	① ✖	LPG	OIL	FUEL
① ✖	NBR, -25 °C to 75 °C	✓	✓		
S2G	VITON, -40 °C to 160 °C	✓	✓	✓	✓

⑱ MEDIA	
CODE	DESCRIPTION
① ✖	Air, Inert Gas, Water
LPG	LPG
Oil	Hydraulic, Turbine, Lubricating
Fuel	Petrol, Diesel, Kerosene, CNG

SIZE-VOLTAGE CURRENT		
CODE	SIZE	COIL VOLTAGE
I-12V DC	I	12V DC
I-24V DC	I	24V DC
III-12V DC	III	12V DC
III-24V DC	III	24V DC
III-24V AC/ DC	III	④ 24V 50Hz/ 60Hz/ DC
III-48V DC	III	48V DC
III-110V DC	III	110V DC
III-110V AC/ DC	III	④ 110V 50Hz/ 60Hz/ DC 120V 50Hz/ 60Hz/ DC
III-220V DC	III	220V DC
III-230V AC/ DC	III	④ 220V 50Hz/ 60Hz/ DC 240V 50Hz/ 60Hz/ DC
III-256V DC	III	256V DC
II-12V DC	II	12V DC
II-24V DC	II	24V DC
II-24V AC/ DC	II	④ 24V 50Hz/ 60Hz/ DC
II-48V DC	II	48V DC
II-110V DC	II	110V DC
II-110V AC/ DC	II	④ 110V 50Hz/ 60Hz/ DC 120V 50Hz/ 60Hz/ DC
II-220V DC	II	220V DC
II-230V AC/ DC	II	④ 220V 50Hz/ 60Hz/ DC 240V 50Hz/ 60Hz/ DC
II-256V DC	II	256V DC
IV-24V DC	IV	24V DC
IV-110V DC	IV	110V DC

ENCLOSURE TYPE	
CODE	DESCRIPTION
<b>WEATHER PROOF</b>	
⑫ 01	Flying Lead Lead 600 mm Long IP 67 (Indoor Application)
⑫ 06	Flying Lead Lead 600 mm Long IP 54 (Indoor Application)
⑫ 22	DIN Plug Solenoid, IP 67, Cable Entry Pg9, as per DIN43650A, Size I
⑫ 25	DIN Plug Solenoid, IP 67, Cable Entry Pg9, as per DIN43650B, Size III, II, IV
16	Integrated Terminal box, IP 67, 1/2" NPT, -40 °C to 100 °C
16A	Integrated Terminal box, IP68, 1/2" NPT, -40°C to 100°C
19	Integrated Terminal box, IP 67, M20 X 1.5, -40 °C to 100 °C
19A	Integrated Terminal box, IP68, M20 X 1.5, -40°C to 100°C
17	Integrated Terminal Box, Bottom Cable entry M25X1.5, Size II, III, IV, Insulation Class H
17NS	Integrated Terminal Box, Bottom Cable entry 1/2" NPT, Size II, III, IV, Insulation Class H
<b>EXPLOSION PROOF Ex d (For Gas &amp; Dust)</b>	
⑮ 37	Ex d IIC IP66, -40 °C TO 60 °C, 1/2" NPT
⑮ 39	Ex d IIC IP66, -40 °C TO 60 °C, M20 X 1.5
87	Ex d IIC IP67, -60 °C TO 100 °C, M25 X 1.5, Size II, III, IV
87MS	Ex d IIC IP67, -60 °C TO 100 °C, M20 X 1.5, Size II, III, IV
87NS	Ex d IIC IP67, -60 °C TO 100 °C, 1/2" NPT, Size II, III, IV
<b>EXPLOSION PROOF Ex e mb (For Gas &amp; Dust)</b>	
58	Ex e mb IIC, IP67, -40 °C TO 70 °C, M25 X 1.5
58MS	Ex e mb IIC, IP67, -40 °C TO 70 °C, M20 X 1.5
58NS	Ex e mb IIC, IP67, -40 °C TO 70 °C, 1/2" NPT
58LT	Ex e mb IIC, IP67, -60 °C TO 70 °C, M25 X 1.5
58LTMS	Ex e mb IIC, IP67, -60 °C TO 70 °C, M20 X 1.5
58LTNS	Ex e mb IIC, IP67, -60 °C TO 70 °C, 1/2" NPT
<b>EXPLOSION PROOF Ex ia (For Gas &amp; Dust)</b>	
62	Ex ia IIC, IP67, -60 °C TO 70 °C, M25 X 1.5, Size IV, Booster Circuit
62MS	Ex ia IIC, IP67, -60 °C TO 70 °C, M20 X 1.5, Size IV, Booster Circuit
62NS	Ex ia IIC, IP67, -60 °C TO 70 °C, 1/2" NPT, Size IV, Booster Circuit

⑰ ENCLOSURE MATERIAL	
CODE	DESCRIPTION
① ✖	Aluminium Cast Epoxy Powder Coated
CO	CF8M (Stainless Steel Cast)

SPECIAL	
CODE	DESCRIPTION
① ✖	NIL
⑰ FR	Full Rectifier with Surge Suppressor Size II, III, IV
⑰ LD	LED, Size II, III, IV
⑰ SS	Surge Suppressor Size II, III, IV
⑰ 26	

**3/2 DIRECT ACTING, HIGH ORIFICE UNIVERSAL SUBBASE MOUNTED SOLENOID VALVE**

POWER													
CODE	SIZE	POWER WATT	12V DC	24V DC	24V AC/ DC	48V DC	110V DC	110V AC/ DC		220V DC	230V AC/ DC		256V DC
			12V DC	24V DC	④ 24V 50Hz/ 60 Hz/ DC	48V DC	110V DC	④ 110V 50Hz/ 60Hz/ DC	④ 120V 50Hz/ 60Hz/ DC	220V DC	④ 220V 50Hz/ 60Hz/ DC	④ 240V 50Hz/ 60Hz/ DC	256V DC
①	*	I	8.0	✓	✓								
LW3.5	III	3.5	✓	✓				✓					
		4.0							✓				
LW5	III	5.0	✓	✓	✓	✓	✓	✓		✓	✓		
		6.0							✓			✓	
①	*	III	8.0	✓	✓	✓	✓	✓	✓	✓	✓		
			9.0							✓			✓
LW15	II	15.0	✓	✓			✓	✓		✓			
		18.0											✓
LW20	II	20.0			✓			✓			✓		
		22.0							✓			✓	
LW1.8	IV	1.8		✓			✓	✓					
⑪	LW1	IV	1.0		✓								

INSULATION	
CODE	DESCRIPTION
① *	CLASS F
H	CLASS H

SIL	
CODE	DESCRIPTION
① *	NO
SL	YES

APPROVAL		⑨ ENCLOSURE TYPE						
CODE	DESCRIPTION	17	37	39	58	58LT	62	87
① ⑮ *	CCOE/ PESO + BIS, Insulation Class H		✓	✓			✓	✓
01	CE - ATEX, Insulation Class H		✓	✓	✓	✓		
01	IEC Ex + ATEX, Insulation Class H						✓	✓
01B	INDIAN + ATEX, Insulation Class H			✓			✓	✓
02	UL Recognised, for USA and Canada, Type 3, 3S, 4, 4X, 6, 6P UL file Number E 342217	✓						
03	INMETRO + ATEX, Insulation Class H		✓	✓			✓	✓
03C	IEC Ex + ATEX + IN METRO + CuTR-EAC							✓
03U	IEC Ex + ATEX + IN METRO + UL (Type 3, 3S, 4, 4X, 6, 6P)	✓						
04	CuTR- EAC + ATEX , Insulation Class H		✓	✓			✓	✓
04U	IEC Ex + ATEX + CuTR + UL (Type 3, 3S, 4, 4X, 6, 6P)	✓						
⑫ 07	KOSHA + ATEX, Insulation Class H							✓
08	Ukraine, Insulation Class H						✓	✓
⑮ MN	DGMS+CCOE/ PESO + BIS, Insulation Class H		✓	✓			✓	✓
⑳ CE	CE (Weatherproof Solenoid)	✓						

**Note :**

- ① Do not specify when opted for
- ② Approval Other than BIS, CCOE/ PESO, DGMS
- ③ BIS, CCOE/ PESO, DGMS Approved coil
- ④ Opt FR from special
- ⑤ Current DC, 50Hz, 60Hz
- ⑦ Do not Opt for Enclosure Type 01, 06, 22, 25
- ⑧ Select Body Material B5 Stainless Steel
- ⑨ All variation of 17, 37, 39, 58, 58LT, 62, 87 included
- ⑪ Enclosure type 17, 17NS, 87, 87MS, 87NS
- ⑫ Current DC
- ⑬ Ambient Temperature restricted for Enclosure Type 17, 37, 39, 58, 58LT, 62, 87 to Solenoid Ambient Temperature
- ⑭ Select Nil or one Accessories from A1 to A6 for Valve and from B1 to B8 for Solenoid and from C1 to C4 for Port or from MF5 to MF42 for Manifold
- ⑮ IP67 Certified by BIS, CCOE/ PESO, DGMS
- ⑰ Type 30316, 30317, 30332, P3014, 30316LW with Suffix TC (Port 3 plugged) can be used as 2 Port NC Bi Directional Valve
- ⑱ Type 30316, 30317, 30332, P3014, 30316LW with Suffix TO (Port 1 plugged) can be used as 2 Port NO Bi Directional Valve
- ⑲ Can not be opted for Enclosure Type 01, 06
- ⑳ Can be opted for Enclosure Type 01, 06, 16, 19, 22, 25
- ㉑ KOSHA Certificate only for Enclosure Size II ≤ 20W
- ㉒ Do not Opt for Enclosure Type 01, 06, 22
- ㉓ Media shall not be part of Ordering code but It shall be printed separately on Valve

**ENTITY PARAMETER**

Entity Parameter	
Ui	32V DC
Ii	230mA
Pi	2.3W
Ci	0
Li	0

**MINIMUM OPERATING PARAMETER**

Type	62	62..LD..
Minimum Voltage (V)	11	12
Minimum Current (mA)	22	24
Minimum Power (W)	0.24	0.26
LED	NO	YES
Pressure (bar)	10	10

**RESPONSE ON TIME FOR SOLENOID TYPE 62, 62..LD..**

Voltage (V)	10	11	12	14	18	22	24	26	30	32	Current (mA)	18.5	20	25	30
Current (mA)	20	22	24	28.5	37	45.5	49.7	54	63	67	Open Ckt Voltage (V)	19.5	19.5	19.5	19.5
Response Time (ms) ≤	4800	3800	2500	1600	850	650	450	400	250	250	Time (ms) ≤	5000	4000	2500	2000

**3/2 DIRECT ACTING, HIGH ORIFICE UNIVERSAL SUBBASE MOUNTED SOLENOID VALVE**

**MARKING Explosion Proof ENCLOSURE TYPE 37/ 39**

SIZE	Power	BIS & PESO, DGMS	EAC - CuTR (Russia)	ATEX / INMETRO
I II IV	≤5W ≤8W ≤11W	Ex d IIC T6/T5 Gb, IP67 Ex tb IIIC T80°C/T95°C Db -40°C ≤ Ta ≤ 65°C FOR T6 -40°C ≤ Ta ≤ 70°C FOR T5	1 Ex d IIC T6/ T5/ T4 Gb IP66 Ex tb IIIC T80°C / T95°C / T130°C Db IP66 ИЛИ 0°C ≤ Ta ≤ 35°C FOR T6 -40°C ≤ Ta ≤ 50°C FOR T5 -40°C ≤ Ta ≤ 60°C FOR T4	Ex d IIC T6/ T5/ T4 Gb IP66 Ex tb IIIC T80°C / T95°C / T130°C Db IP66 -40°C ≤ Ta ≤ 35°C FOR T6 -40°C ≤ Ta ≤ 50°C FOR T5 -40°C ≤ Ta ≤ 60°C FOR T4 (Power ≤ 20W)
I II III	≤8W ≤13W ≤8W	Ex d IIC T6/T5 Gb, IP67 Ex tb IIIC T80°C/T95°C Db -40°C ≤ Ta ≤ 60°C FOR T6 -40°C ≤ Ta ≤ 70°C FOR T5		
III	≤15W	Ex d IIC T6/T5/T4 ≤Gb, IP67 Ex tb IIIC T80°C/T95°C/T130°C Db -40°C ≤ Ta ≤ 50°C FOR T6 -40°C ≤ Ta ≤ 65°C FOR T5 -40°C ≤ Ta ≤ 70°C FOR T4		
III IV	≤5W ≤5W	Ex d IIC T6 Gb, IP67 Ex tb IIIC T80°C Db -40°C ≤ Ta ≤ 70°C FOR T6		
II	≤20W	Ex d IIC T6/T5 Gb, IP67 Ex tb IIIC T80°C / T95°C Db -40°C ≤ Ta ≤ 55°C FOR T6 -40°C ≤ Ta ≤ 70°C FOR T5		
II	≤30W	Ex d IIC T6/T5/T4 Gb, IP67 Ex tb IIIC T80°C/T95°C/T130°C Db -40°C ≤ Ta ≤ 40°C FOR T6 -40°C ≤ Ta ≤ 55°C FOR T5 -40°C ≤ Ta ≤ 70°C FOR T4		

**ENCLOSURE TYPE 87**

SIZE	Power	ATEX, IEC Ex, BIS & PESO, DGMS	INMETRO	EAC - CuTR (Russia) / UKRAINE	KOSHA
III II IV	≤5W ≤8W ≤11W	Ex d IIC T6/T5/T4 Gb IP67 Ex t IIIC T80°C/T95°C/T130°C Db IP67 -60°C ≤ Ta ≤ +65°C for T6 -60°C ≤ Ta ≤ +80°C for T5 -60°C ≤ Ta ≤ +100°C for T4	Ex d IIC T6/T5/T4 Gb Ex t IIIC T85°C/T100°C/T135°C Db IP67 -60°C ≤ Ta ≤ +65°C for T6 -60°C ≤ Ta ≤ +80°C for T5 -60°C ≤ Ta ≤ +100°C for T4	1 Ex d IIC T6/T5/T4 Gb IP67 Ex tb IIIC T80°C/T95°C/T130°C Db ИЛИ -60°C ≤ Ta ≤ +65°C for T6 -60°C ≤ Ta ≤ +80°C for T5 -60°C ≤ Ta ≤ +100°C for T4	형식 또는 모델명 : 87, BCE 규격 또는 등급 : Ex d IIC T3-T6 제조자명 : Rotex Automation Limited 안전인증 번호 : 15-AV4BO-0000
III II	≤8W ≤13W	Ex d IIC T6/T5/T4 Gb IP67 Ex t IIIC T80°C/T95°C/T130°C Db IP67 -60°C ≤ Ta ≤ +60°C for T6 -60°C ≤ Ta ≤ +75°C for T5 -60°C ≤ Ta ≤ +100°C for T4	Ex d IIC T6/T5/T4 Gb Ex t IIIC T85°C/T100°C/T135°C Db IP67 -60°C ≤ Ta ≤ +60°C for T6 -60°C ≤ Ta ≤ +75°C for T5 -60°C ≤ Ta ≤ +100°C for T4	1 Ex d IIC T6/T5/T4 Gb IP67 Ex tb IIIC T80°C/T95°C/T130°C Db ИЛИ -60°C ≤ Ta ≤ +60°C for T6 -60°C ≤ Ta ≤ +75°C for T5 -60°C ≤ Ta ≤ +100°C for T4	
III	≤15W	Ex d IIC T6/T5/T4 Gb IP67 Ex t IIIC T80°C/T95°C/T130°C Db IP67 -60°C ≤ Ta ≤ +50°C for T6 -60°C ≤ Ta ≤ +65°C for T5 -60°C ≤ Ta ≤ +100°C for T4	Ex d IIC T6/T5/T4 Gb Ex t IIIC T85°C/T100°C/T135°C Db IP67 -60°C ≤ Ta ≤ +50°C for T6 -60°C ≤ Ta ≤ +65°C for T5 -60°C ≤ Ta ≤ +100°C for T4	1 Ex d IIC T6/T5/T4 Gb IP67 Ex tb IIIC T80°C/T95°C/T130°C Db ИЛИ -60°C ≤ Ta ≤ +50°C for T6 -60°C ≤ Ta ≤ +65°C for T5 -60°C ≤ Ta ≤ +100°C for T4	
IV	≤5W	Ex d IIC T6/T5/T4 Gb IP67 Ex t IIIC T80°C/T95°C/T130°C Db IP67 -60°C ≤ Ta ≤ +70°C for T6 -60°C ≤ Ta ≤ +85°C for T5 -60°C ≤ Ta ≤ +100°C for T4	Ex d IIC T6/T5/T4 Gb Ex t IIIC T85°C/T100°C/T135°C Db IP67 -60°C ≤ Ta ≤ +70°C for T6 -60°C ≤ Ta ≤ +85°C for T5 -60°C ≤ Ta ≤ +100°C for T4	1 Ex d IIC T6/T5/T4 Gb IP67 Ex tb IIIC T80°C/T95°C/T130°C Db ИЛИ -60°C ≤ Ta ≤ +70°C for T6 -60°C ≤ Ta ≤ +85°C for T5 -60°C ≤ Ta ≤ +100°C for T4	
II	≤20W	Ex d IIC T5/T4/T3 Gb IP67 Ex IIIC T95°C/T130°C/155°C Db IP67 -60°C ≤ Ta ≤ +45°C for T5 -60°C ≤ Ta ≤ +80°C for T4 -60°C ≤ Ta ≤ +100°C for T3	Ex d IIC T5/T4/T3 Gb Ex IIIC T100°C/T135°C/155°C Db IP67 -60°C ≤ Ta ≤ +45°C for T5 -60°C ≤ Ta ≤ +80°C for T4 -60°C ≤ Ta ≤ +100°C for T3	1 Ex d IIC T5/T4/T3 Gb IP67 Ex tb IIIC T95°C/T130°C/T155°C Db ИЛИ -60°C ≤ Ta ≤ +45°C for T5 -60°C ≤ Ta ≤ +80°C for T4 -60°C ≤ Ta ≤ +100°C for T3	
II	≤30W	Ex d IIC T4/T3 Gb IP67 Ex IIIC T130°C/T155°C Db IP67 -60°C ≤ Ta ≤ +60°C for T4 -60°C ≤ Ta ≤ +70°C for T3	Ex d IIC T4/T3 Gb Ex IIIC T135°C/T155°C Db IP67 -60°C ≤ Ta ≤ +60°C for T4 -60°C ≤ Ta ≤ +70°C for T3	1 Ex d IIC T4/T3 Gb IP67 Ex tb IIIC T130°C/T155°C Db ИЛИ -60°C ≤ Ta ≤ +60°C for T4 -60°C ≤ Ta ≤ +70°C for T3	

**3/2 DIRECT ACTING, HIGH ORIFICE UNIVERSAL SUBBASE MOUNTED SOLENOID VALVE**

**MARKING Explosion Proof**

**ENCLOSURE TYPE 58**

SIZE	Power	CE-ATEX, Insulation H
I	≤5W	Ex e mb IIC T6/ T5 IP67
II	≤8W	Ex tb IIIC T6/ T5 IP67
IV	≤11W	-40° C ≤ Ta ≤ 65° C for T6 -40° C ≤ Ta ≤ 70° C for T5
I	≤8W	Ex e mb IIC T6/ T5 IP67
II	≤13W	Ex tb IIIC T6/ T5 IP67
III	≤8W	-40° C ≤ Ta ≤ 60° C for T6 -40° C ≤ Ta ≤ 70° C for T5
III	≤15W	Ex e mb IIC T6/ T5/ T4 IP67 Ex tb IIIC T6/ T5/ T4 IP67 -40° C ≤ Ta ≤ 50° C for T6 -40° C ≤ Ta ≤ 65° C for T5 -40° C ≤ Ta ≤ 70° C for T4
III	≤5W	Ex e mb IIC T6 IP67
IV	≤5W	Ex tb IIIC T6 IP67 -40° C ≤ Ta ≤ 70° C for T6
II	≤20W	Ex e mb IIC T6/ T5 IP67 Ex tb IIIC T6/ T5 IP67 -40° C ≤ Ta ≤ 55° C for T6 -40° C ≤ Ta ≤ 70° C for T5
II	≤30W	Ex e mb IIC T6/ T5/ T4 IP67 Ex tb IIIC T6/ T5/ T4 IP67 -40° C ≤ Ta ≤ 40° C for T6 -40° C ≤ Ta ≤ 55° C for T5 -40° C ≤ Ta ≤ 70° C for T4

**ENCLOSURE TYPE 58LT**

SIZE	Power	CE-ATEX, Insulation H
I	≤5W	Ex e mb IIC T6/ T5 IP67
II	≤8W	Ex tb IIIC T6/ T5 IP67
IV	≤11W	-60° C ≤ Ta ≤ 65° C for T6 -60° C ≤ Ta ≤ 70° C for T5
I	≤8W	Ex e mb IIC T6/ T5 IP67
II	≤13W	Ex tb IIIC T6/ T5 IP67
III	≤8W	-60° C ≤ Ta ≤ 60° C for T6 -60° C ≤ Ta ≤ 70° C for T5
III	≤15W	Ex e mb IIC T6/ T5/ T4 IP67 Ex tb IIIC T6/ T5/ T4 IP67 -60° C ≤ Ta ≤ 50° C for T6 -60° C ≤ Ta ≤ 65° C for T5 -60° C ≤ Ta ≤ 70° C for T4
III	≤5W	Ex e mb IIC T6 IP67
IV	≤5W	Ex tb IIIC T6 IP67 -60° C ≤ Ta ≤ 70° C for T6
II	≤20W	Ex e mb IIC T6/ T5 IP67 Ex tb IIIC T6/ T5 IP67 -60° C ≤ Ta ≤ 55° C for T6 -60° C ≤ Ta ≤ 70° C for T5
II	≤30W	Ex e mb IIC T6/ T5/ T4 IP67 Ex tb IIIC T6/ T5/ T4 IP67 -60° C ≤ Ta ≤ 40° C for T6 -60° C ≤ Ta ≤ 55° C for T5 -60° C ≤ Ta ≤ 70° C for T4

**ENCLOSURE TYPE 62**

Enclosure	ATEX/ IECEx (Eurpoe)/ INMETRO/ CEPTEL (Brazil)	EAC - CuTR (Russia)	BIS & PESO, DGMS
Al Cast	Ex ia IIC T5 Ga (-60°C ≤ Ta ≤ +75°C) Ex ia IIC T6 Ga (-60°C ≤ Ta ≤ +60°C) Ex ia IIIC T200 125°C IP67 Da (-60°C ≤ Ta ≤ +75°C)	0 Ex ia IIC T5 Ga IP67 (-60°C ≤ Ta ≤ +75°C) 0 Ex ia IIC T6 Ga IP67 (-60°C ≤ Ta ≤ +60°C) 0 Ex ia IIIC T200 125°C IP67 Da (-60°C ≤ Ta ≤ +75°C)	Ex ia I/IIIC T5, IP67 (-40°C ≤ Ta ≤ 75°C) Ex ia I/IIIC T6, IP67 (-40°C ≤ Ta ≤ 60°C)
SS Cast	Ex ia IIC T5 Ga (-60°C ≤ Ta ≤ +75°C) Ex ia IIC T6 Ga (-60°C ≤ Ta ≤ +60°C) Ex ia IIIC T200 125°C IP67 Da (-60°C ≤ Ta ≤ +75°C) Ex ia I Ma (-60°C ≤ Ta ≤ +75°C)	0 Ex ia IIC T5 Ga IP67 (-60°C ≤ Ta ≤ +75°C) 0 Ex ia IIC T6 Ga IP67 (-60°C ≤ Ta ≤ +60°C) 0 Ex ia IIIC T200 125°C IP67 Da (-60°C ≤ Ta ≤ +75°C) PO Ex ia I Ma (-60°C ≤ Ta ≤ +75°C) (ТОЛЬКО СТАЛЬ) ИЛИ	
	<b>Ukraine</b>		
Al Cast	0 Ex ia IIC T5 X -60°C ≤ Ta ≤ +75°C 0 Ex ia IIC T6 X -60°C ≤ Ta ≤ +60°C		
SS Cast	PO Иа X -60°C ≤ Ta ≤ +75°C (ДЛЯ варианта у стальному корпусі) 0 Ex ia IIC T5 X -60°C ≤ Ta ≤ +75°C 0 Ex ia IIC T6 X -60°C ≤ Ta ≤ +60°C		

**MARKING Weather Proof**

**ENCLOSURE TYPE 17**

US & Canada (UL Recognised)
TYPE 3, 3R, 3S, 4, 4X, 6 & 6P
-60°C to +100°C POWER ≤20W
-60°C to +60°C 20W < POWER ≤30W



**3/2 DIRECT ACTING, HIGH ORIFICE UNIVERSAL SUBBASE MOUNTED SOLENOID VALVE**



14 ACCESSORIES		
	CODE	DESCRIPTION
	① ✖	NIL
	A1	NRV Metallic Dust cap SS316, ideally suited for Protecting Valve internals from external Environment (Ambient Temperature - 60 °C to 150 °C), Water, Snow, Bugs, etc.
	A3	Silencer Sintered Bronze
	A4	Silencer Sintered SS
	A5	Dust Cap (Ambient Temperature - 20 °C to 80 °C)
	A6	NRV Dust cap Nylon, ideally suited for preventing external Environmental Media/ Water/ Liquid entering in the valve. Supplied only for 1/4" BSP/ NPT (Ambient Temperature - 20 °C to 80 °C)
	① ✖	NIL
	C1 to C10	Adaptor plate refer page 10 & 13
	① ✖	NIL
	B1	Weather Proof Cable Gland M20X1.5(M) Brass
	B5	ATEX Approved Cable Gland (Plastic) M20X1.5(M) (Ambient Temperature - 20 °C to 80 °C)
	B6	ATEX Approved Cable Gland (BRASS) M20X1.5(M) (Ambient Temperature - 20 °C to 80 °C)
	B7	ATEX Approved Cable Gland (SS316) M20X1.5(M) (Ambient Temperature - 20 °C to 80 °C)
	B8	Weather Proof Cable gland M20X1.5(M) (Plastic)
	B3	Explosion Proof Double Compression Cable Gland (BRASS) 1/2" NPT(M) (Ambient Temperature - 20 °C to 80 °C), CCOE/ PESO Certified
	B4	Explosion Proof Double Compression Cable Gland (SS316) 1/2" NPT(M) (Ambient Temperature - 20 °C to 80 °C), CCOE/ PESO Certified

VALVE

PORT

SOLENOID

**3/2 DIRECT ACTING, HIGH ORIFICE UNIVERSAL SUBBASE MOUNTED SOLENOID VALVE**

14 ACCESSORIES		
	CODE	DESCRIPTION
	C1	Adaptor plate 1/4" BSP for 30316, Aluminium hard anodised
	C2	Adaptor plate 1/4" NPT for 30316, Aluminium hard anodised
	C3	Adaptor plate 1/4" BSP for 30317-7, 30332-7, Aluminium hard anodised
	C4	Adaptor plate 1/4" NPT for 30317-7, 30332-7, Aluminium hard anodised
	C5	Adaptor plate 3/8" BSP for 30317-7,30332-7, Aluminium hard anodised
	C6	Adaptor plate 3/8" NPT for 30317-7, 30332-7, Aluminium hard anodised
	C7	Adaptor plate 3/8" BSP for 30317V01-10, 30332-10, Aluminium hard anodised
	C8	Adaptor plate 3/8" NPT for 30317V01-10, 30332-10, Aluminium hard anodised
	C9	Adaptor plate 1/2" BSP for 30317V01-10, 30332-10, Aluminium hard anodised
	C10	Adaptor plate 1/2" NPT for 30317V01-10, 30332-10, Aluminium hard anodised
	MF005 MF017	Manifold for valve type 30316-5, Aluminium hard anodised
	MF006 MF044	Manifold for valve type 30317-7, 30332-7, Aluminium hard anodised
	MF007 MF018	Manifold for valve type 30317V01-10, 30332-10, Aluminium hard anodised

PORT

MANIFOLD

**SERIES : 32D**

**3/2 DIRECT ACTING, HIGH ORIFICE UNIVERSAL SUBBASE MOUNTED SOLENOID VALVE**

**DIMENSIONS**

All Dimensions are in mm

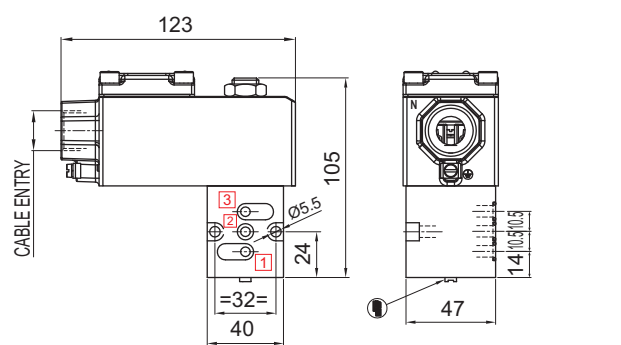
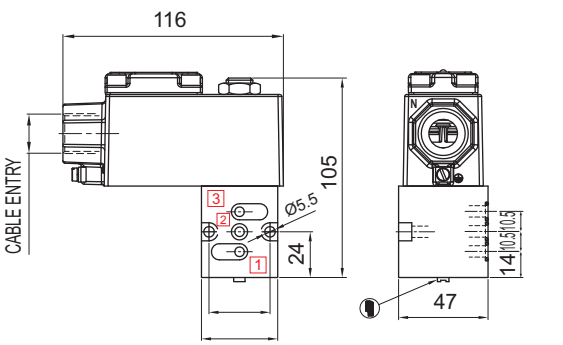
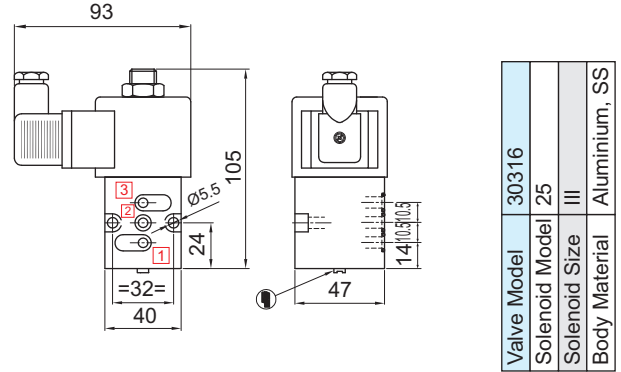
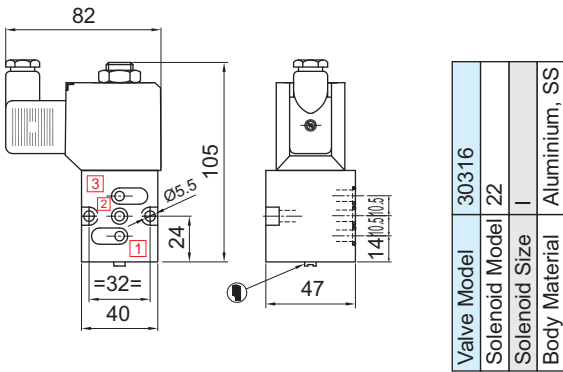

Valve Model	30316
Solenoid Model	16, 19, 37, 39
Solenoid Size	I
Body Material	Aluminium, SS

Valve Model	30316, P3014
Solenoid Model	16, 19, 37, 39
Solenoid Size	III
Body Material	Aluminium, SS

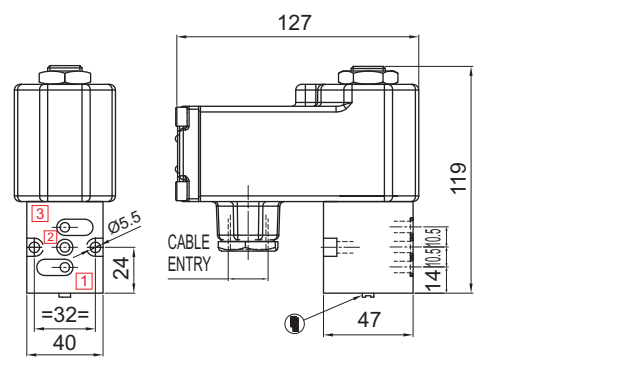
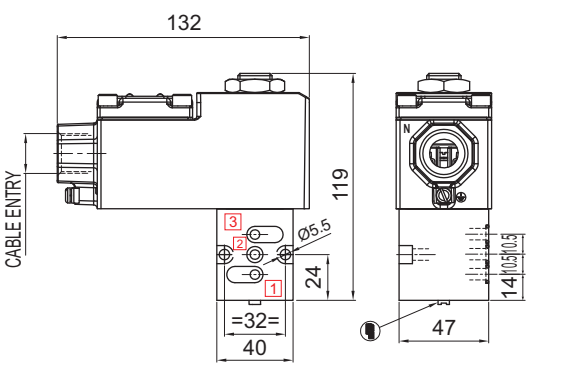
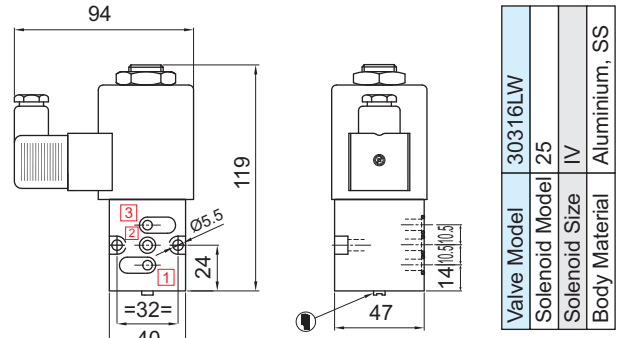
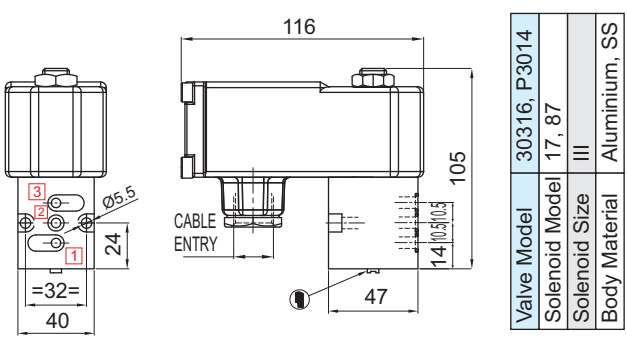

Valve Model	30316LW
Solenoid Model	16, 19, 37, 39
Solenoid Size	IV
Body Material	Aluminium, SS

Valve Model	30316LW
Solenoid Model	17, 87, 62
Solenoid Size	IV
Body Material	Aluminium, SS

**3/2 DIRECT ACTING, HIGH ORIFICE UNIVERSAL SUBBASE MOUNTED SOLENOID VALVE**

**DIMENSIONS**

All Dimensions are in mm

**30317, 30332-7**

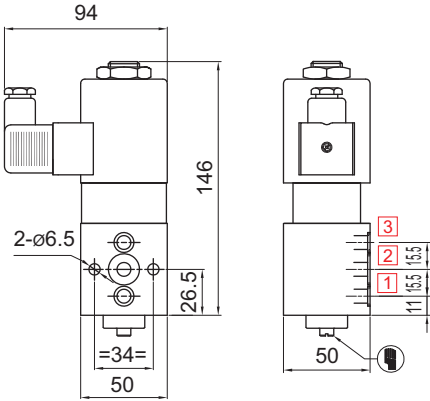

Valve Model	30317-7, 30332-7
Solenoid Model	25
Solenoid Size	II
Body Material	Aluminium, SS

**30317V01, 30332-10**

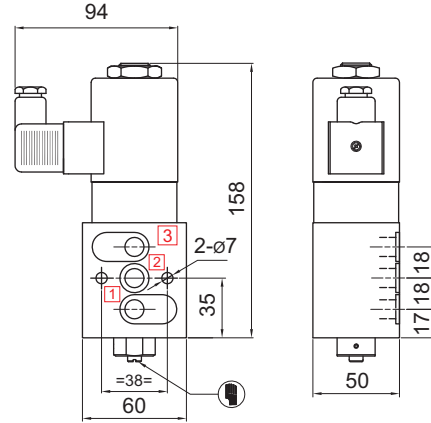

Valve Model	30317V01-10, 30332-10
Solenoid Model	25
Solenoid Size	II
Body Material	Aluminium, SS

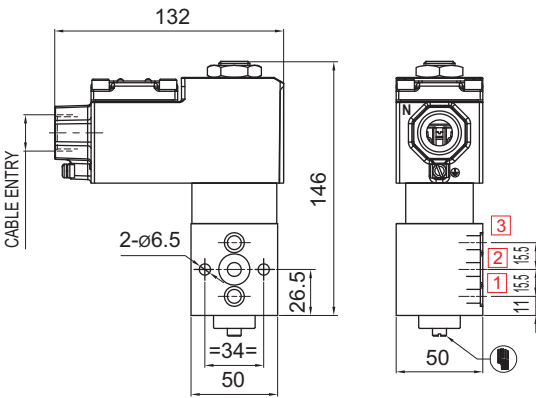

Valve Model	30317-7, 30332-7
Solenoid Model	16, 19, 37, 39, 58, 58LT
Solenoid Size	II
Body Material	Aluminium, SS

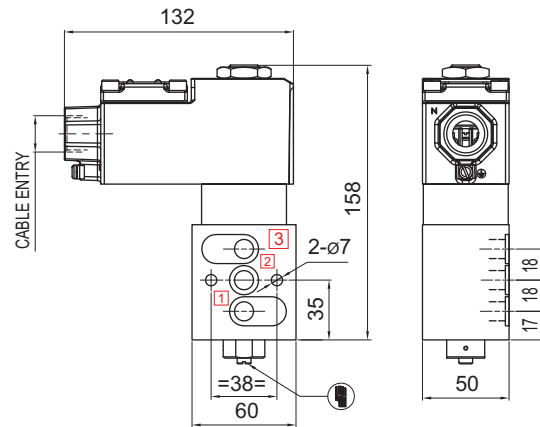

Valve Model	30317V01-10, 30332-10
Solenoid Model	16, 19, 37, 39, 58, 58LT
Solenoid Size	II
Body Material	Aluminium, SS

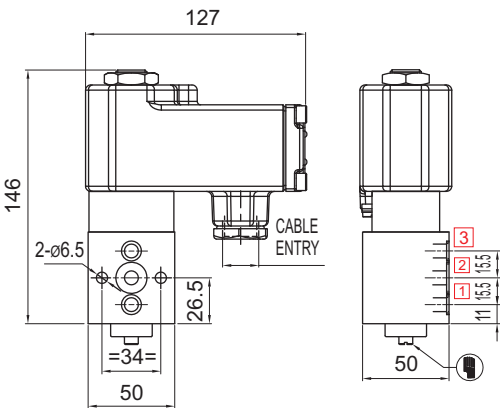

Valve Model	30317-7, 30332-7
Solenoid Model	17, 87
Solenoid Size	II
Body Material	Aluminium, SS

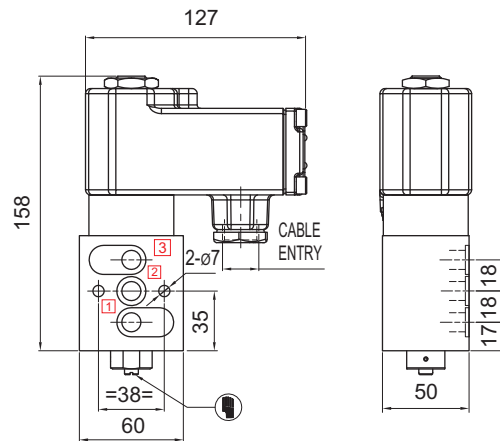

Valve Model	30317V01-10, 30332-10
Solenoid Model	17, 87
Solenoid Size	II
Body Material	Aluminium, SS

**SERIES : 32D**

**3/2 DIRECT ACTING, HIGH ORIFICE UNIVERSAL SUBBASE MOUNTED SOLENOID VALVE**

**ADAPTER PLATE**

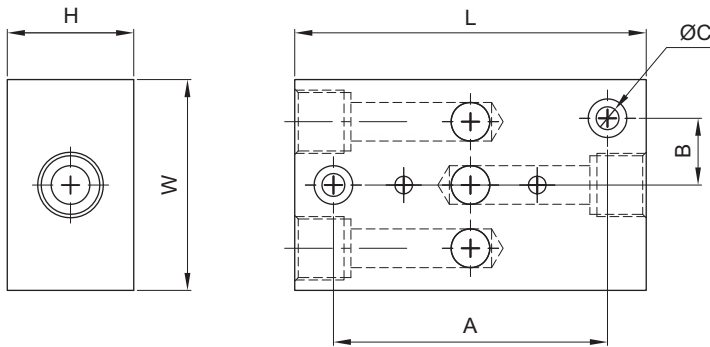

Adopter Plate	K (Port Size)	L	W	H	A	B	C	Orifice
C1/C2	1/4"	70	40	24	54	12	5.5	5
C3/C4	1/4"	80	56	32	60	15.5	6.5	7
C5/C6	3/8"	80	56	32	60	15.5	6.5	7
C7/C8	3/8"	100	65	36	78	18	6.5	10
C9/C10	1/2"	100	65	36	78	18	6.5	10

**MANIFOLD**

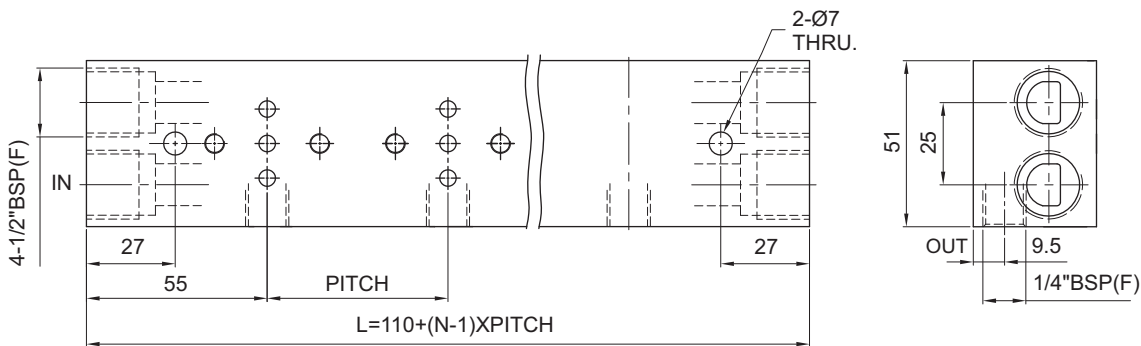

Manifold Type	Type	Max. No. of Manifold	PITCH
MF005	30316, 30316LW, P3014	12	55
MF006	30317-7, 30332-7	08	55
MF007	30317V01-10, 30332-10	08	65

**MANIFOLD WITH ISOLATION COCK**

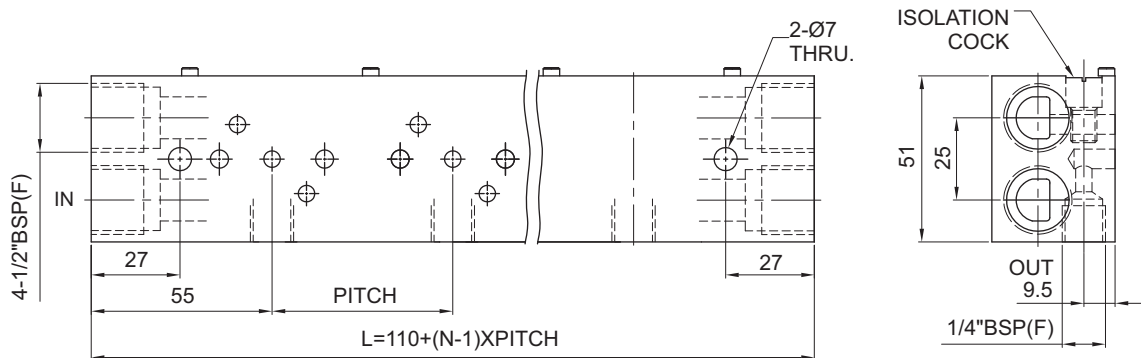

Manifold Type	Type	Max. No. of Manifold	PITCH
MF017	30316, 30316LW, P3014	12	55
MF044	30317-7, 30332-7	08	55
MF018	30317V01-10, 30332-10	08	65



**ROTEX AUTOMATION LIMITED**

987 / 11,  
GIDC Makarpura,  
Vadodara - 390 010,  
Gujarat, India  
Ph: +91 265 6174 100

**OVERSEAS OFFICE**

**ROTEX AUTOMATION EUROPE**

Bierstraat 117,  
3011 XA Rotterdam,  
The Netherlands  
Ph. : +31 88 5053 505  
europe@rotexautomation.com

**ROTEX AUTOMATION FZ LLC**

CT01 - 09, C ustom Building 01,  
AL Hamra Industrial Zone - FZ,  
RAK, United Arab Emirates  
Ph. : +971 50 9627 404  
mena@rotexautomation.com



@rotexautomation



www.rotexautomation.com



info@rotexautomation.com